

CATALOG

DRUM MOTOR

DM 0080

DM 0113

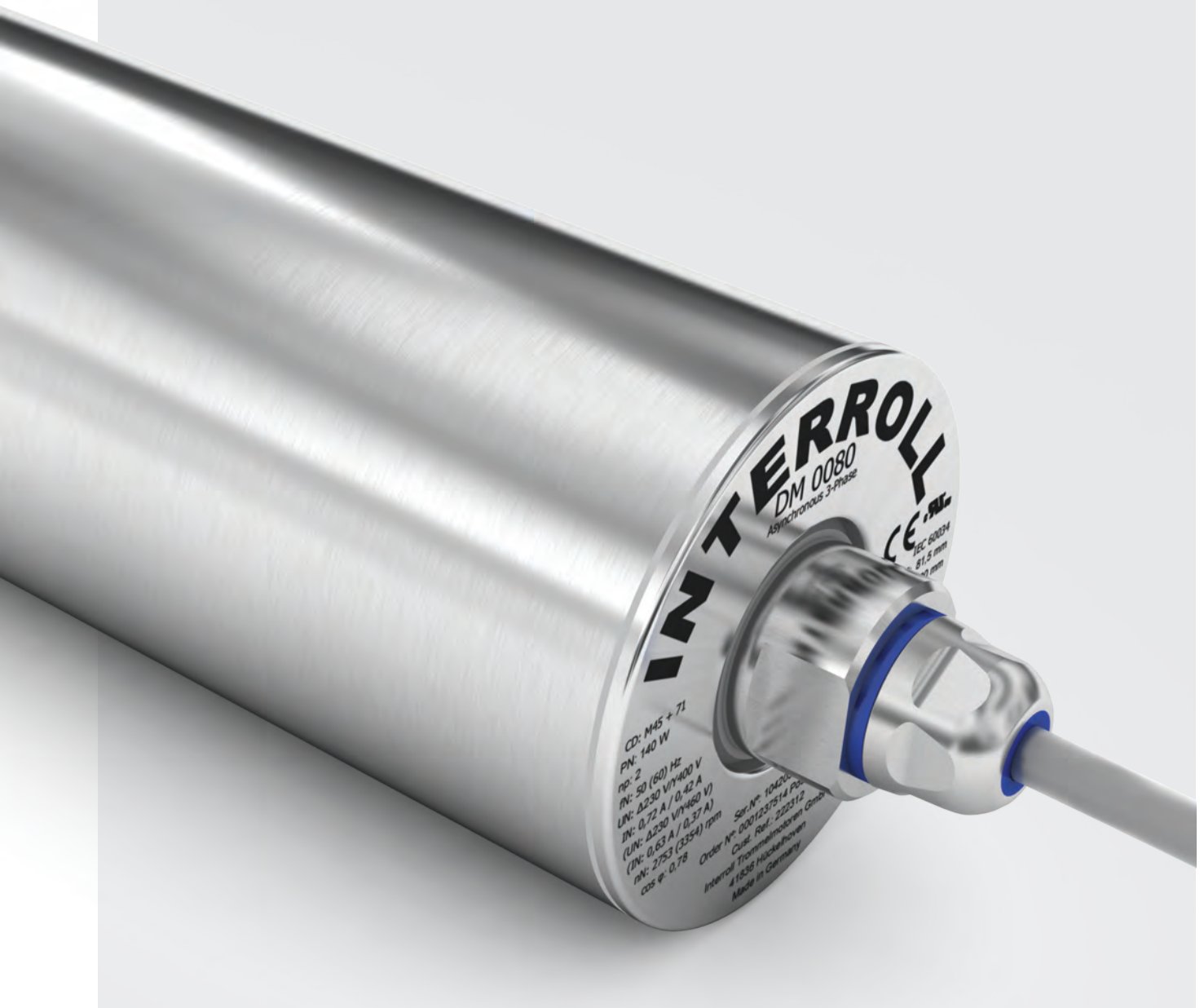

"Inspired by Efficiency"

Smart handling of resources is mandatory for Interroll. Because we are convinced that efficiency is a fundamental value. It drives us to constantly improve products and processes. Efficiency inspires our daily activities.

"Inspired by Efficiency" means: We develop products for internal logistics that perfectly adapt to the needs of our customers.

As global market leader in technology and innovation in our industry, we believe that strengthening the business of our customers in a significant and lasting way is our responsibility. For Interroll, the key to success is the consistent pursuit of efficiency.

Symbols



Drum motor



Idler pulley



Options



Accessories

Contents

| | |
|---------------------------------------|----|
| The Interroll Group | 4 |
| Interroll core products and solutions | 6 |
| The highly efficient belt drive | 8 |
| Interroll platform for drum motors | 10 |
| Drum motor DM 0080 | 12 |
| Drum motor DM 0113 | 28 |
| Options | 52 |
| Accessories | 80 |
| Application notes | 94 |



www.interroll.com

The Interroll Group is a globally leading supplier of high-quality key products and services for internal logistics. The company, which is listed on the stock exchange and has its headquarters in Switzerland, employs some 2000 people in 32 companies around the globe.

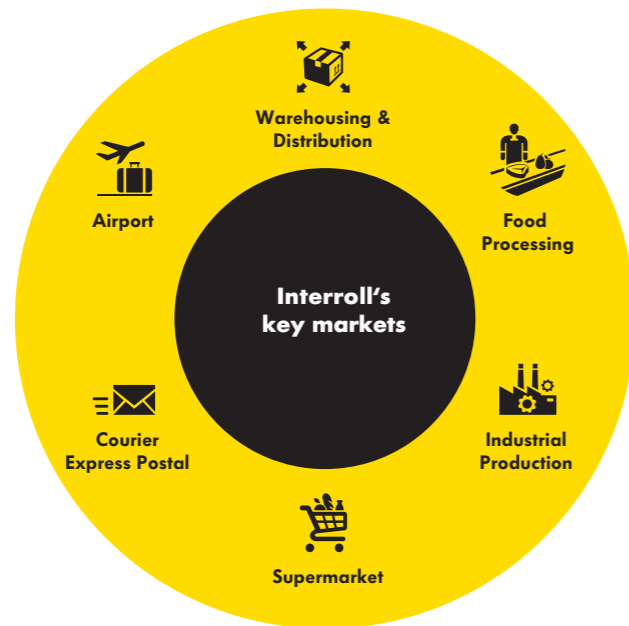

-  Holding
-  Sales, Production & Service
-  Global Competence Centers
-  Regional Competence Centers

The solutions for our customers' daily logistical challenges are based on Interroll key products that are built on a worldwide common platform.



Conveying

Versatile and reliable core products ensure a dynamic, efficient material flow across all continents and in all industries:

- Conveyor rollers
- 24 V motor rollers (RollerDrive)
- Controls for RollerDrive
- Drum motors and idler pulleys
- Pallet drive and control (PalletDrive and PalletControl)

They are used to convey, accumulate, feed or remove goods. Powered or with the force of gravity. With or without dynamic pressure. Easy-to-install drive solutions for new plants or for refurbishing existing plants. Excellent products that will pay for themselves and that you can rely on. In every respect.



Transporting and distributing

Millions of different individual items travel through the world's flow of goods every day and must be delivered on time to the correct destination. This is a trend that requires a performance-based logistics system with efficient material flow systems. Interroll's innovative conveyor modules and subsystems are always ready for key locations in customers' systems:

- Crossbelt sorters
- Belt curves and belt merges
- Conveyor modules with zero-pressure accumulation
- Roller conveyors
- Belt conveyors

Precisely pre-assembled and rapidly delivered for fast, simple integration into the complete system on site (plug and play). The conveyor modules and subsystems provide users with key assurances: excellent availability whilst being easy to use; outstanding efficiency even at low throughput volumes; efficient investment with a short period of return on investment; adaptability in the event of change.

Storage and picking

Economical and user-friendly: the dynamic storage solution that operates without power. It is designed for fast-moving goods (e.g. groceries) that have to be quickly picked and immediately conveyed to consumers. The principle is as simple as it is ingenious. It is known as FIFO, First In – First Out, and guarantees that what has been stored first is also picked first. Or LIFO, Last In – First Out, when the pallet stored last is picked first. It means making maximum use of minimum space. The needs of our customers are as diverse as our products, therefore our

- Pallet Flow
- Carton Flow

peripheral subsystems offer unlimited design options. The picking times can scarcely be beaten. The return on investment for the operator is two to three years and is integrated into "Just in Time".





Compact, robust and absolutely hygienic

Since the drum motor is installed directly in the frame of the conveyor belt in a space-saving way, the transport capacity is maximized given the same base area. Positive side effect: Elegantly designed conveyor belts with evenly distributed weights. The installation or replacement of a drum motor is generally simple and quick using the plug-and-play principle, because only a few components have to be installed - thus saving time and money. In food processing, perfect hygiene and good cleaning options are especially important: This is where the drum motor scores big with its encapsulated design made of stainless steel.



Proven principle, efficient drive

In principle, drum motors are energy-efficient because they directly drive the conveyor belt. In addition, they are practically maintenance-free and extremely wear-resistant, thereby significantly reducing the operating costs of the conveyor system and the risk of standstills or breakdowns. By the way: High-quality sealing systems ensure that a drum motor will also run reliably in aggressive environments.

The Interroll synchronous drum motors have a very low power loss of only 9 %. The planetary gear box made of steel transfers 92 – 95 % of the power directly to the conveyor. They are especially suited to applications where a high-torque, dynamic drive, a wide speed range, or high duty cycles are necessary.



All-rounder with a broad application range

Drum motor applications are varied: When used in friction-driven belts, the motor is cooled directly via the belt tensioned over the drum shell. Modular plastic belts are not tensioned; in this case, the drive is form-fit via sprockets or a profile lagging. Solid homogeneous belts are also positive driven, whereby a profile on the underside of the belt engages in a drum profile made of hygienically certified PU. But it also works entirely without a belt and the drum motor transports the material directly.

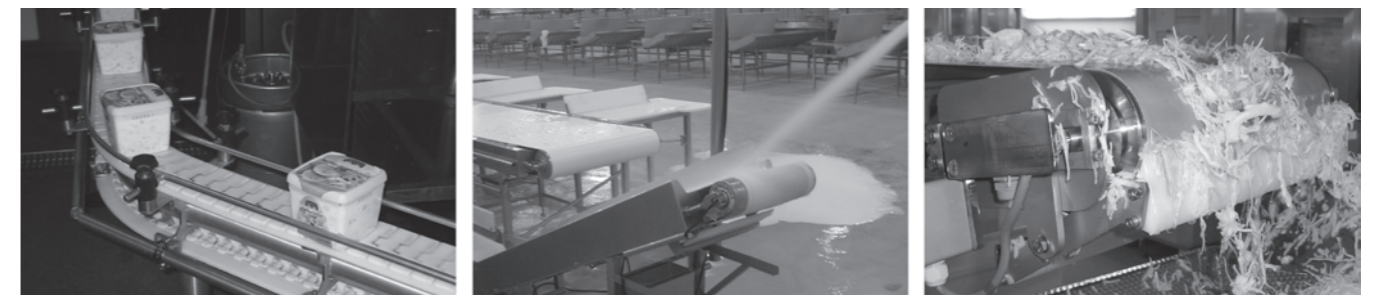

Practice-oriented, scalable, and thought out in detail

The new drum motor platform from Interroll combines the different motor concepts in a single design and makes it easy for customers to build their own and completely individual conveyor system. Since all motors have the same shafts, the number of different parts from the original equipment manufacturer is reduced and conveyor construction is significantly easier. The broad speed spectrum covers all imaginable applications. The clever plug-and-play solution makes installation easier. Each motor is approved, tested, and modularized so that it can be produced and delivered around the world in the shortest amount of time.



Flexibility and robustness make the difference



More performance, more configurability

The broad range of services for the motors covers all conceivable uses in the food industry, intralogistics and manufacturing. All motors are optimized for their application, giving planning personnel the freedom to choose between synchronous and asynchronous designs.



Tested quality, innovative technology

All motor components are standardized, tested, and approved in elaborate testing. Modularized motor types have been developed for all current applications; they are quickly available and contribute to minimizing costs.



More hygienic

All Interroll Drum Motors of the new generation meet the highest standards of hygiene according to IP69k. This gives users the assurance that the cleaning process meets the highest standard.



Fewer breakdowns

A stable planetary gear train is enough for a high torque in all motors, holds up against bending, and resists overloads and impact loads. The result is safer, more reliable operation.



Lower costs, more service

The clever plug-and-play wiring solution and simple installation, assembly and maintenance ensure noticeable savings in time and costs, as well as reduced downtimes of the conveyor system. Replacement parts available worldwide through Interroll and service partners make repairs easy and offer a faster, better service.



More stability

The strong 30 mm shaft and the larger ball bearings on Interroll's new drum motors allow significantly higher belt tensions. It provides a safety net even in cases of a defective belt tracking or overtensioned conveyor belts.

| | DM 0080 | DM 0080 | DM 0080 | DM 0080 | DM 0080 | DM 0113 | DM 0113 | DM 0113 |
|----------------------|----------------|-----------------|-----------------|----------------|-----------------|-----------------|-----------------|-----------------|
| Motor technology | Asynchronous | Asynchronous | Asynchronous | Asynchronous | Synchronous | Asynchronous | Asynchronous | Synchronous |
| No. phase | 3-phase | 3-phase | 1-phase | 1-phase | 3-phase | 1-phase | | |
| Diameter | 81.5 mm | 81.5 mm | 81.5 mm | 81.5 mm | 81.5 mm | 113 mm | 113 mm | 113 mm |
| Gear material | Steel | Technopolymer | Steel | Technopolymer | Steel | Steel | Steel | Steel |
| Rated power | 40 – 140 W | 40 – 75 W | 25 – 110 W | 25 – 110 W | 145 – 425 W | 160 – 550 W | 250 W | 300 – 1100 W |
| Rated torque | 1.2 – 59.8 Nm | 3.2 – 20.3 Nm | 0.8 – 39.2 Nm | 4.5 – 21.4 Nm | 2.1 – 65 Nm | 6.7 – 157 Nm | 19.1 – 71.5 Nm | 5.4 – 132.7 Nm |
| Max. belt pull | 1467 N | 498 N | 961 N | 525 N | 1594 N | 2779 N | 1265 N | 2349 N |
| Speed of the shell | 0.03 – 2.5 m/s | 0.07 – 0.87 m/s | 0.05 – 2.49 m/s | 0.05 – 0.9 m/s | 0.08 – 2.72 m/s | 0.05 – 1.85 m/s | 0.18 – 0.67 m/s | 0.16 – 2.96 m/s |
| Drum width (FW) | 200 – 1200 mm | 239 – 1200 mm | 250 – 1200 mm | 287 – 1200 mm | 192 – 1200 mm | 257 – 1400 mm | 297 – 1400 mm | 207 – 1400 mm |
| Friction-driven belt | ● | ● | ● | ● | ● | ● | ● | ● |
| Positive driven belt | ● | – | – | – | ● | ● | – | ● |
| Without belt | ● | – | – | – | ● | ● | – | ● |

Other drum widths on request



Practice-oriented, scalable and thought out in detail: The new drum motor DM 0080 makes it easy to build a completely individual conveyor system and is dimensioned for the higher requirements for permissible belt tension from industry and belt manufacturers.

With a broader speed spectrum, the DM 0080 covers all possible applications. The clever plug-and-play connection significantly simplifies the installation. Each motor is approved, tested, and modularized so that it can be produced and delivered around the world in the shortest amount of time.

The modular design of the DM 0080 allows a free combination of individual module groups, such as shaft, end cover, shell, steel or technopolymer gear, asynchronous or synchronous motor winding, to perfectly meet the requirements of an application. In addition, various options, such as encoder, brake, backstop, rubber laggings, etc., as well as different accessories are available.

With the platform concept of the DM 0080, it is possible to cover all internal logistics applications in the food processing sector, as well as in industry, distribution and airports.



Technical data

| | Asynchronous squirrel cage motor | AC synchronous permanent magnet motor |
|--|--|---|
| Insulation class of motor windings | Class F, IEC 34 (VDE 0530) | Class F, IEC 34 (VDE 0530) |
| Voltage | 230/400 V ±5 % (IEC 34/38) Most of the common international voltages and frequencies are available upon request | 230 or 400 V |
| Frequency | 50 Hz | 200 Hz |
| Shaft seal, internal | NBR | NBR |
| Protection rate | IP69K | IP69K |
| Thermal protection | Bi-metal switch | Bi-metal switch |
| Operating mode | S1 | S1 |
| Ambient temperature, 3-phase motor | +2 to +40 °C Low temperature ranges on request | +2 to +40 °C Low temperature ranges on request |
| Ambient temperature, 3-phase motor for applications with positive driven belts or no belt | +2 to +25 °C | +2 to +40 °C |

Design variants and accessories

| | |
|--------------------|---|
| Laggings | Lagging for friction drive belts Lagging for modular plastic belts Lagging for positive drive solid homogeneous belts |
| Sprockets | Sprockets for modular plastic belts |
| Options | Backstop Electromagnetic holding brake and rectifier Feedback devices Balancing Plug connection |
| Oils | Food-grade oils (EU, FDA) |
| Certificate | cULus safety certificates |
| Accessories | Idler pulleys; conveyor rollers; mounting brackets; cables; inverters |

A combination of encoder and safety holding brake is not possible. In addition, the use of a backstop with a synchronous motor is technically not meaningful.

Material variants

The following components can be selected for the drum motor and the electrical connection.
The combination of components depends on the material used.

| Component | Version | Aluminum | Mild steel | Stainless steel | Brass/nickel | Technopolymer |
|-----------------------------|---------------------------------|----------|------------|-----------------|--------------|---------------|
| Shell | Crowned | | ● | ● | | |
| | Cylindrical | | ● | ● | | |
| | Cylindrical + key for sprockets | | ● | ● | | |
| End housing | Standard | ● | | ● | | |
| Shaft | Standard | | ● | ● | | |
| | Cross-drilled thread | | ● | ● | | |
| Gear boxes | Planetary gear box | | ● | | | ● |
| Electrical connector | Straight connector | | | ● | ● | ● |
| | Straight hygienic connector | | | ● | | |
| | Elbow connector | | | ● | | ● |
| | Terminal box | ● | | ● | | |
| | Straight plug connection | | | ● | | |
| Motor winding | Asynchronous motor | | | | | |
| | Synchronous motor | | | | | |
| External seal | PTFE | | | | | |

Motor variants

Mechanical data for synchronous motors with steel gear

| P _N [W] | np | gs | i | v [m/s] | n _A [min ⁻¹] | M _A [Nm] | F _N [N] | M _{MAX} /M _A | FW _{MIN} [mm] | SL _{MIN} [mm] |
|-----------------------|----|----|--------|------------|--|------------------------|-----------------------|----------------------------------|---------------------------|---------------------------|
| 145 | 8 | 3 | 164.23 | 0.078 | 18.3 | 65.0 | 1595 | 1.4 | 211 | 204 |
| 145 | 8 | 3 | 119.83 | 0.11 | 25.0 | 47.4 | 1164 | 2.1 | 211 | 204 |
| 145 | 8 | 3 | 103.89 | 0.12 | 28.9 | 41.1 | 1009 | 2.5 | 211 | 204 |
| 145 | 8 | 3 | 85.34 | 0.15 | 35.2 | 33.8 | 829 | 3.0 | 211 | 204 |
| 145 | 8 | 2 | 62.7 | 0.20 | 47.8 | 26.0 | 637 | 2.2 | 192 | 185 |
| 145 | 8 | 2 | 53.63 | 0.24 | 55.9 | 22.2 | 545 | 2.5 | 192 | 185 |
| 145 | 8 | 2 | 42.28 | 0.30 | 71.0 | 17.5 | 430 | 3.0 | 192 | 185 |
| 145 | 8 | 2 | 38.5 | 0.33 | 77.9 | 15.9 | 392 | 3.0 | 192 | 185 |
| 145 | 8 | 2 | 31.35 | 0.41 | 95.7 | 13.0 | 319 | 3.0 | 192 | 185 |
| 145 | 8 | 2 | 26.94 | 0.48 | 111.4 | 11.2 | 274 | 3.0 | 192 | 185 |
| 145 | 8 | 2 | 20.27 | 0.63 | 148.0 | 8.4 | 206 | 3.0 | 192 | 185 |
| 145 | 8 | 2 | 14.44 | 0.89 | 207.8 | 6.0 | 147 | 3.0 | 192 | 185 |
| 145 | 8 | 2 | 11.23 | 1.14 | 267.1 | 4.6 | 115 | 3.0 | 192 | 185 |
| 145 | 8 | 1 | 8.25 | 1.55 | 363.6 | 3.6 | 89 | 3.0 | 192 | 185 |
| 145 | 8 | 1 | 4.71 | 2.72 | 636.9 | 2.1 | 51 | 3.0 | 192 | 185 |
| 298 | 8 | 2 | 53.63 | 0.24 | 55.9 | 45.9 | 1126 | 1.2 | 222 | 215 |
| 298 | 8 | 2 | 42.28 | 0.30 | 71.0 | 36.1 | 888 | 1.5 | 222 | 215 |
| 298 | 8 | 2 | 38.5 | 0.33 | 77.9 | 32.9 | 808 | 1.6 | 222 | 215 |
| 298 | 8 | 2 | 31.35 | 0.41 | 95.7 | 26.8 | 658 | 3.0 | 222 | 215 |
| 298 | 8 | 2 | 26.94 | 0.48 | 111.4 | 23.0 | 566 | 3.0 | 222 | 215 |
| 298 | 8 | 2 | 20.27 | 0.63 | 148.0 | 17.3 | 426 | 3.0 | 222 | 215 |
| 298 | 8 | 2 | 14.44 | 0.89 | 207.8 | 12.3 | 303 | 3.0 | 222 | 215 |
| 298 | 8 | 2 | 11.23 | 1.14 | 267.1 | 9.6 | 236 | 3.0 | 222 | 215 |
| 298 | 8 | 1 | 8.25 | 1.55 | 363.6 | 7.4 | 183 | 3.0 | 222 | 215 |
| 298 | 8 | 1 | 4.71 | 2.72 | 636.9 | 4.3 | 105 | 3.0 | 222 | 215 |

| P_N [W] | np | gs | i | v [m/s] | n_A [min ⁻¹] | M_A [Nm] | F_N [N] | M_{MAX}/M_A | FW_{MIN} [mm] | SL_{MIN} [mm] |
|--------------|----|----|-------|------------|-------------------------------|---------------|--------------|---------------|--------------------|--------------------|
| 425 | 8 | 2 | 38.5 | 0.33 | 77.9 | 46.8 | 1148 | 1.2 | 252 | 245 |
| 425 | 8 | 2 | 31.35 | 0.41 | 95.7 | 38.1 | 935 | 2.6 | 252 | 245 |
| 425 | 8 | 2 | 26.94 | 0.48 | 111.4 | 32.7 | 804 | 3.0 | 252 | 245 |
| 425 | 8 | 2 | 20.27 | 0.63 | 148.0 | 24.6 | 605 | 3.0 | 252 | 245 |
| 425 | 8 | 2 | 14.44 | 0.89 | 207.8 | 17.5 | 431 | 3.0 | 252 | 245 |
| 425 | 8 | 2 | 11.23 | 1.14 | 267.1 | 13.6 | 335 | 3.0 | 252 | 245 |
| 425 | 8 | 1 | 8.25 | 1.55 | 363.6 | 10.6 | 260 | 2.5 | 252 | 245 |
| 425 | 8 | 1 | 4.71 | 2.72 | 636.9 | 6.0 | 149 | 3.0 | 252 | 245 |
| 700 | 8 | 2 | 38.5 | 0.5 | 116.9 | 51.6 | 1267 | 1.1 | 252 | 245 |
| 700 | 8 | 2 | 31.35 | 0.62 | 143.5 | 42.0 | 1032 | 2.3 | 252 | 245 |
| 700 | 8 | 2 | 26.94 | 0.72 | 167.0 | 36.1 | 887 | 2.7 | 252 | 245 |
| 700 | 8 | 2 | 20.27 | 0.95 | 222.0 | 27.2 | 667 | 3.0 | 252 | 245 |
| 700 | 8 | 2 | 14.44 | 1.33 | 311.6 | 19.4 | 475 | 3.0 | 252 | 245 |
| 700 | 8 | 2 | 11.23 | 1.71 | 400.7 | 15.1 | 370 | 3.0 | 252 | 245 |
| 700 | 8 | 1 | 8.25 | 2.33 | 545.5 | 11.7 | 287 | 2.3 | 252 | 245 |

- P_N = Rated power
- np = Number of poles
- gs = Gear stages
- i = Speed ratio
- v = Speed
- n_A = Shell rated speed
- M_A = Drum motor rated torque
- F_N = Drum motor rated belt pull
- M_{MAX}/M_A = Ratio of max. acceleration torque to rated torque
- FW_{MIN} = Minimum drum width
- SL_{MIN} = Minimum shell length

Electrical data for synchronous motors

| P_N [W] | np | U_N [V] | I_N [A] | I_0 [A] | I_{MAX} [A] | f_N [Hz] | η | n_N [rpm] | J_R [kgcm ²] | M_N [Nm] | M_0 [Nm] | M_{MAX} [Nm] | R_M [Ω] | L_{SD} [mH] | L_{SQ} [mH] | k_e [V/krpm] | T_e [ms] | k_{TN} [Nm/A] | U_{SH} [V] |
|--------------|----|--------------|--------------|--------------|------------------|---------------|--------|----------------|-------------------------------|---------------|---------------|-------------------|--------------|------------------|------------------|-------------------|---------------|--------------------|-----------------|
| 145 | 8 | 230 | 0.81 | 0.81 | 2.43 | 200 | 0.85 | 3000 | 0.14 | 0.46 | 0.46 | 1.38 | 21.6 | 45.60 | 53.70 | 41.57 | 4.97 | 0.57 | 25 |
| 145 | 8 | 400 | 0.47 | 0.47 | 1.41 | 200 | 0.83 | 3000 | 0.14 | 0.46 | 0.46 | 1.38 | 62.5 | 130.7 | 138.0 | 72.23 | 4.41 | 0.98 | 36 |
| 298 | 8 | 230 | 1.30 | 1.30 | 3.90 | 200 | 0.86 | 3000 | 0.28 | 0.95 | 0.95 | 2.85 | 10.2 | 27.80 | 29.30 | 47.46 | 5.75 | 0.73 | 19 |
| 298 | 8 | 400 | 0.78 | 0.78 | 2.34 | 200 | 0.87 | 3000 | 0.28 | 0.95 | 0.95 | 2.85 | 29.1 | 81.90 | 94.10 | 83.09 | 6.48 | 1.22 | 32 |
| 425 | 8 | 230 | 2.30 | 2.30 | 6.90 | 200 | 0.87 | 3000 | 0.42 | 1.35 | 1.35 | 4.05 | 5.66 | 16.26 | 19.42 | 45.81 | 6.86 | 0.59 | 19 |
| 425 | 8 | 400 | 1.32 | 1.32 | 3.96 | 200 | 0.86 | 3000 | 0.42 | 1.35 | 1.35 | 4.05 | 17.6 | 49.80 | 59.00 | 80.80 | 6.70 | 1.02 | 33 |
| 700 | 8 | 400 | 2.52 | 2.52 | 6.78 | 300 | 0.87 | 4500 | 0.42 | 1.49 | 1.49 | 4.0 | 5.66 | 16.26 | 19.42 | 45.81 | 6.86 | 0.59 | ?? |

- P_N = Rated power
- np = Number of poles
- U_N = Rated voltage
- I_N = Rated current
- I_0 = Standstill current
- I_{MAX} = Maximum current
- f_N = Rated frequency
- η = Efficiency
- n_N = Rated torque of rotor
- J_R = Rotor moment of inertia
- M_N = Rated torque of rotor
- M_0 = Standstill torque
- M_{MAX} = Maximum torque
- R_M = Phase to phase resistance
- L_{SD} = d-axis inductance
- L_{SQ} = q-axis inductance
- k_e = EMF (mutual induction voltage constant)
- T_e = Electrical time constant
- k_{TN} = Torque constant
- U_{SH} = Heating voltage

Mechanical data for 3-phase asynchronous motor with steel gear

| P_N [W] | np | gs | i | v [m/s] | n_A [min ⁻¹] | M_A [Nm] | F_N [N] | FW_{MIN} [mm] | SL_{MIN} [mm] |
|--------------|----|----|--------|------------|-------------------------------|---------------|--------------|--------------------|--------------------|
| 40 | 4 | 3 | 164.23 | 0.03 | 7.8 | 42.4 | 1040 | 219 | 212 |
| 40 | 4 | 3 | 119.83 | 0.05 | 10.7 | 30.9 | 759 | 219 | 212 |
| 40 | 4 | 3 | 103.89 | 0.05 | 12.3 | 26.8 | 658 | 219 | 212 |
| 40 | 4 | 3 | 85.34 | 0.06 | 15.0 | 22.0 | 541 | 219 | 212 |
| 40 | 4 | 2 | 62.70 | 0.09 | 20.4 | 16.9 | 416 | 200 | 193 |
| 40 | 4 | 2 | 53.63 | 0.10 | 23.8 | 14.5 | 356 | 200 | 193 |
| 40 | 4 | 2 | 42.28 | 0.13 | 30.2 | 11.4 | 281 | 200 | 193 |
| 40 | 4 | 2 | 38.50 | 0.14 | 33.2 | 10.4 | 256 | 200 | 193 |
| 40 | 4 | 2 | 31.35 | 0.17 | 40.8 | 8.5 | 208 | 200 | 193 |
| 40 | 4 | 2 | 26.94 | 0.20 | 47.4 | 7.3 | 179 | 200 | 193 |
| 40 | 4 | 2 | 20.27 | 0.27 | 63.0 | 5.5 | 135 | 200 | 193 |
| 40 | 4 | 2 | 14.44 | 0.38 | 88.5 | 3.9 | 96 | 200 | 193 |
| 40 | 4 | 2 | 11.23 | 0.49 | 113.8 | 3.0 | 75 | 200 | 193 |
| 40 | 4 | 1 | 8.25 | 0.66 | 154.9 | 2.4 | 58 | 200 | 193 |
| 40 | 4 | 1 | 4.71 | 1.16 | 271.3 | 1.3 | 33 | 200 | 193 |
| 75 | 2 | 3 | 164.23 | 0.07 | 16.2 | 38.1 | 936 | 219 | 212 |
| 75 | 2 | 3 | 119.83 | 0.10 | 22.2 | 27.8 | 683 | 219 | 212 |
| 75 | 2 | 3 | 103.89 | 0.11 | 25.6 | 24.1 | 592 | 219 | 212 |
| 75 | 2 | 3 | 85.34 | 0.13 | 31.2 | 19.8 | 486 | 219 | 212 |
| 75 | 2 | 2 | 62.70 | 0.18 | 42.4 | 15.2 | 374 | 200 | 193 |
| 75 | 2 | 2 | 53.63 | 0.21 | 49.6 | 13.0 | 320 | 200 | 193 |
| 75 | 2 | 2 | 42.28 | 0.27 | 62.9 | 10.3 | 252 | 200 | 193 |
| 75 | 2 | 2 | 38.50 | 0.30 | 69.1 | 9.4 | 230 | 200 | 193 |
| 75 | 2 | 2 | 31.35 | 0.36 | 84.8 | 7.6 | 187 | 200 | 193 |
| 75 | 2 | 2 | 26.94 | 0.42 | 98.7 | 6.5 | 161 | 200 | 193 |
| 75 | 2 | 2 | 20.27 | 0.56 | 131.2 | 4.9 | 121 | 200 | 193 |
| 75 | 2 | 2 | 14.44 | 0.79 | 184.1 | 3.5 | 86 | 200 | 193 |
| 75 | 2 | 2 | 11.23 | 1.01 | 236.8 | 2.7 | 67 | 200 | 193 |
| 75 | 2 | 1 | 8.25 | 1.38 | 322.3 | 2.1 | 52 | 200 | 193 |
| 75 | 2 | 1 | 4.71 | 2.41 | 564.5 | 1.2 | 30 | 200 | 193 |
| 80 | 4 | 3 | 119.83 | 0.05 | 10.9 | 59.8 | 1467 | 269 | 262 |
| 80 | 4 | 3 | 103.89 | 0.05 | 12.6 | 51.8 | 1272 | 269 | 262 |

| P_N [W] | np | gs | i | v [m/s] | n_A [min ⁻¹] | M_A [Nm] | F_N [N] | FW_{MIN} [mm] | SL_{MIN} [mm] |
|--------------|----|----|--------|------------|-------------------------------|---------------|--------------|--------------------|--------------------|
| 80 | 4 | 3 | 85.34 | 0.07 | 15.3 | 42.6 | 1045 | 269 | 262 |
| 80 | 4 | 2 | 62.70 | 0.09 | 20.9 | 32.7 | 804 | 250 | 243 |
| 80 | 4 | 2 | 53.63 | 0.10 | 24.4 | 28.0 | 687 | 250 | 243 |
| 80 | 4 | 2 | 42.28 | 0.13 | 30.9 | 22.1 | 542 | 250 | 243 |
| 80 | 4 | 2 | 38.50 | 0.15 | 34.0 | 20.1 | 494 | 250 | 243 |
| 80 | 4 | 2 | 31.35 | 0.18 | 41.7 | 16.4 | 402 | 250 | 243 |
| 80 | 4 | 2 | 26.94 | 0.21 | 48.6 | 14.1 | 345 | 250 | 243 |
| 80 | 4 | 2 | 20.27 | 0.28 | 64.5 | 10.6 | 260 | 250 | 243 |
| 80 | 4 | 2 | 14.44 | 0.39 | 90.6 | 7.5 | 185 | 250 | 243 |
| 80 | 4 | 2 | 11.23 | 0.50 | 116.5 | 5.9 | 144 | 250 | 243 |
| 80 | 4 | 1 | 8.25 | 0.68 | 158.5 | 4.5 | 112 | 250 | 243 |
| 80 | 4 | 1 | 4.71 | 1.18 | 277.7 | 2.6 | 64 | 250 | 243 |
| 140 | 2 | 3 | 119.83 | 0.10 | 23.0 | 50.5 | 1239 | 269 | 262 |
| 140 | 2 | 3 | 103.89 | 0.11 | 26.5 | 43.8 | 1074 | 269 | 262 |
| 140 | 2 | 3 | 85.34 | 0.14 | 32.3 | 36.0 | 883 | 269 | 262 |
| 140 | 2 | 2 | 62.70 | 0.19 | 43.9 | 27.7 | 679 | 250 | 243 |
| 140 | 2 | 2 | 53.63 | 0.22 | 51.3 | 23.7 | 580 | 250 | 243 |
| 140 | 2 | 2 | 42.28 | 0.28 | 65.1 | 18.6 | 458 | 250 | 243 |
| 140 | 2 | 2 | 38.50 | 0.31 | 71.5 | 17.0 | 417 | 250 | 243 |
| 140 | 2 | 2 | 31.35 | 0.38 | 87.8 | 13.8 | 339 | 250 | 243 |
| 140 | 2 | 2 | 26.94 | 0.44 | 102.2 | 11.9 | 292 | 250 | 243 |
| 140 | 2 | 2 | 20.27 | 0.58 | 135.8 | 8.9 | 219 | 250 | 243 |
| 140 | 2 | 2 | 14.44 | 0.81 | 190.7 | 6.4 | 156 | 250 | 243 |
| 140 | 2 | 2 | 11.23 | 1.05 | 245.1 | 5.0 | 122 | 250 | 243 |
| 140 | 2 | 1 | 8.25 | 1.42 | 333.7 | 3.8 | 94 | 250 | 243 |
| 140 | 2 | 1 | 4.71 | 2.49 | 584.5 | 2.2 | 54 | 250 | 243 |

For applications with positive driven belts or applications without belt, the power must be reduced by 17 %.

- P_N = Rated power
- np = Number of poles
- gs = Gear stages
- i = Speed ratio
- v = Speed
- n_A = Shell rated speed
- M_A = Drum motor rated torque
- F_N = Drum motor rated belt pull
- FW_{MIN} = Minimum drum width
- SL_{MIN} = Minimum shell length

Mechanical data for 3-phase asynchronous motor with technopolymer gear

| P_N [W] | n_p | g_s | i | v [m/s] | n_A [min ⁻¹] | M_A [Nm] | F_N [N] | FW_{MIN} [mm] | SL_{MIN} [mm] |
|--------------|-------|-------|-------|--------------|-------------------------------|---------------|--------------|--------------------|--------------------|
| 40 | 4 | 3 | 78.55 | 0.07 | 16.3 | 20.3 | 498 | 239 | 232 |
| 40 | 4 | 3 | 71.56 | 0.08 | 17.9 | 18.5 | 454 | 239 | 232 |
| 40 | 4 | 3 | 63.51 | 0.09 | 20.1 | 16.4 | 403 | 239 | 232 |
| 40 | 4 | 3 | 52.92 | 0.10 | 24.1 | 13.7 | 336 | 239 | 232 |
| 40 | 4 | 3 | 48.79 | 0.11 | 26.2 | 12.6 | 309 | 239 | 232 |
| 40 | 4 | 3 | 43.3 | 0.13 | 29.5 | 11.2 | 275 | 239 | 232 |
| 40 | 4 | 2 | 19.2 | 0.28 | 66.6 | 5.2 | 128 | 239 | 232 |
| 40 | 4 | 2 | 16 | 0.34 | 79.9 | 4.3 | 106 | 239 | 232 |
| 40 | 4 | 2 | 13.09 | 0.42 | 97.6 | 3.5 | 87 | 239 | 232 |
| 75 | 2 | 3 | 78.55 | 0.14 | 33.9 | 18.2 | 448 | 239 | 232 |
| 75 | 2 | 3 | 71.56 | 0.16 | 37.2 | 16.6 | 408 | 239 | 232 |
| 75 | 2 | 3 | 63.51 | 0.18 | 41.9 | 14.7 | 362 | 239 | 232 |
| 75 | 2 | 3 | 52.92 | 0.21 | 50.2 | 12.3 | 302 | 239 | 232 |
| 75 | 2 | 3 | 48.79 | 0.23 | 54.5 | 11.3 | 278 | 239 | 232 |
| 75 | 2 | 3 | 43.3 | 0.26 | 61.4 | 10.1 | 247 | 239 | 232 |
| 75 | 2 | 2 | 19.2 | 0.59 | 138.5 | 4.7 | 114 | 239 | 232 |
| 75 | 2 | 2 | 16 | 0.71 | 166.2 | 3.9 | 95 | 239 | 232 |
| 75 | 2 | 2 | 13.09 | 0.87 | 203.1 | 3.2 | 78 | 239 | 232 |

For applications with positive driven belts or applications without belt, this combination of motor and gear box is not recommended.

| | |
|-------------------------|------------------------------------|
| P_N = Rated power | n_A = Shell rated speed |
| n_p = Number of poles | M_A = Drum motor rated torque |
| g_s = Gear stages | F_N = Drum motor rated belt pull |
| i = Speed ratio | FW_{MIN} = Minimum drum width |
| v = Speed | SL_{MIN} = Minimum shell length |

Electrical data for 3-phase asynchronous motor

| P_N [W] | n_p | n_N [min ⁻¹] | f_N [Hz] | U_N [V] | I_N [A] | $\cos\phi$ | η | J_R [kgcm ²] | I_s/I_N | M_s/M_N | M_p/M_N | M_B/M_N | M_N [Nm] | R_M [Ω] | $U_{SH\Delta}$ [V] | U_{SHY} [V] |
|--------------|-------|-------------------------------|---------------|--------------|--------------|------------|--------|-------------------------------|-----------|-----------|-----------|-----------|---------------|--------------|-----------------------|------------------|
| 40 | 4 | 1278 | 50 | 230 | 0.38 | 0.72 | 0.37 | 0.67 | 1.69 | 1.27 | 1.27 | 1.47 | 0.3 | 294.5 | 40.44 | - |
| 40 | 4 | 1278 | 50 | 400 | 0.22 | 0.72 | 0.37 | 0.67 | 1.69 | 1.27 | 1.27 | 1.47 | 0.3 | 294.5 | - | 70.04 |
| 75 | 2 | 2659 | 50 | 230 | 0.43 | 0.82 | 0.54 | 0.67 | 2.78 | 1.50 | 1.50 | 1.72 | 0.27 | 164.4 | 29.29 | - |
| 75 | 2 | 2659 | 50 | 400 | 0.25 | 0.82 | 0.54 | 0.67 | 2.78 | 1.50 | 1.50 | 1.72 | 0.27 | 164.4 | - | 50.33 |
| 80 | 4 | 1308 | 50 | 230 | 0.64 | 0.68 | 0.46 | 1.25 | 2.02 | 1.60 | 1.60 | 1.68 | 0.58 | 132.5 | 28.74 | - |
| 80 | 4 | 1308 | 50 | 400 | 0.37 | 0.68 | 0.46 | 1.25 | 2.02 | 1.60 | 1.60 | 1.68 | 0.58 | 132.5 | - | 49.78 |
| 140 | 2 | 2753 | 50 | 230 | 0.72 | 0.79 | 0.63 | 1.25 | 3.34 | 1.89 | 1.89 | 2.10 | 0.49 | 72.7 | 20.64 | - |
| 140 | 2 | 2753 | 50 | 400 | 0.42 | 0.79 | 0.63 | 1.25 | 3.34 | 1.89 | 1.89 | 2.10 | 0.49 | 72.7 | - | 35.75 |

| | |
|---------------------------------|--|
| P_N = Rated power | I_s/I_N = Ratio of startup current - rated current |
| n_p = Number of poles | M_s/M_N = Ratio of startup torque - rated torque |
| n_N = Rated speed of rotor | M_B/M_N = Ratio of pull-out torque - rated torque |
| f_N = Rated frequency | M_p/M_N = Ratio of pull-up torque - rated torque |
| U_N = Rated voltage | M_N = Rated torque of rotor |
| I_N = Rated current | R_M = Branch resistance |
| $\cos\phi$ = Power factor | $U_{SH\Delta}$ = Heater voltage in delta connection |
| η = Efficiency | U_{SHY} = Heater voltage in star connection |
| J_R = Rotor moment of inertia | |

Mechanical data for 1-phase asynchronous motor with steel gear

| P_N [W] | np | gs | i | v [m/s] | n_A [1/min] | M_A [Nm] | F_N [N] | FW_{MIN} [mm] | SL_{MIN} [mm] |
|--------------|----|----|--------|------------|------------------|---------------|--------------|--------------------|--------------------|
| 25 | 4 | 3 | 119.83 | 0.05 | 11.0 | 18.5 | 455 | 269 | 262 |
| 25 | 4 | 3 | 103.89 | 0.05 | 12.7 | 16.1 | 395 | 269 | 262 |
| 25 | 4 | 3 | 85.34 | 0.07 | 15.5 | 13.2 | 324 | 269 | 262 |
| 25 | 4 | 2 | 62.7 | 0.09 | 21.1 | 10.2 | 249 | 250 | 243 |
| 25 | 4 | 2 | 53.63 | 0.11 | 24.6 | 8.7 | 213 | 250 | 243 |
| 25 | 4 | 2 | 42.28 | 0.13 | 31.2 | 6.8 | 168 | 250 | 243 |
| 25 | 4 | 2 | 38.5 | 0.15 | 34.3 | 6.2 | 153 | 250 | 243 |
| 25 | 4 | 2 | 31.35 | 0.18 | 42.1 | 5.1 | 125 | 250 | 243 |
| 25 | 4 | 2 | 26.94 | 0.21 | 49.0 | 4.4 | 107 | 250 | 243 |
| 25 | 4 | 2 | 20.27 | 0.28 | 65.1 | 3.3 | 81 | 250 | 243 |
| 25 | 4 | 2 | 14.44 | 0.39 | 91.4 | 2.3 | 57 | 250 | 243 |
| 25 | 4 | 2 | 11.23 | 0.50 | 117.5 | 1.8 | 45 | 250 | 243 |
| 25 | 4 | 1 | 8.25 | 0.68 | 160.0 | 1.4 | 35 | 250 | 243 |
| 25 | 4 | 1 | 4.71 | 1.20 | 280.3 | 0.8 | 20 | 250 | 243 |
| 75 | 2 | 3 | 119.83 | 0.10 | 22.9 | 26.8 | 658 | 269 | 262 |
| 75 | 2 | 3 | 103.89 | 0.11 | 26.5 | 23.2 | 570 | 269 | 262 |
| 75 | 2 | 3 | 85.34 | 0.14 | 32.2 | 19.1 | 468 | 269 | 262 |
| 75 | 2 | 2 | 62.7 | 0.19 | 43.9 | 14.7 | 360 | 250 | 243 |
| 75 | 2 | 2 | 53.63 | 0.22 | 51.3 | 12.5 | 308 | 250 | 243 |
| 75 | 2 | 2 | 42.28 | 0.28 | 65.0 | 9.9 | 243 | 250 | 243 |
| 75 | 2 | 2 | 38.5 | 0.31 | 71.4 | 9.0 | 221 | 250 | 243 |
| 75 | 2 | 2 | 31.35 | 0.37 | 87.7 | 7.3 | 180 | 250 | 243 |
| 75 | 2 | 2 | 26.94 | 0.44 | 102.1 | 6.3 | 155 | 250 | 243 |
| 75 | 2 | 2 | 20.27 | 0.58 | 135.7 | 4.7 | 116 | 250 | 243 |
| 75 | 2 | 2 | 14.44 | 0.81 | 190.4 | 3.4 | 83 | 250 | 243 |
| 75 | 2 | 2 | 11.23 | 1.04 | 244.9 | 2.6 | 64 | 250 | 243 |
| 75 | 2 | 1 | 8.25 | 1.42 | 333.3 | 2.0 | 50 | 250 | 243 |
| 75 | 2 | 1 | 4.71 | 2.49 | 583.9 | 1.2 | 29 | 250 | 243 |
| 85 | 2 | 3 | 119.83 | 0.10 | 22.9 | 30.9 | 759 | 269 | 262 |
| 85 | 2 | 3 | 103.89 | 0.11 | 26.5 | 26.8 | 658 | 269 | 262 |
| 85 | 2 | 3 | 85.34 | 0.14 | 32.2 | 22.0 | 540 | 269 | 262 |
| 85 | 2 | 2 | 62.7 | 0.19 | 43.9 | 16.9 | 415 | 250 | 243 |

| P_N [W] | np | gs | i | v [m/s] | n_A [1/min] | M_A [Nm] | F_N [N] | FW_{MIN} [mm] | SL_{MIN} [mm] |
|--------------|----|----|--------|------------|------------------|---------------|--------------|--------------------|--------------------|
| 85 | 2 | 2 | 53.63 | 0.22 | 51.3 | 14.5 | 355 | 250 | 243 |
| 85 | 2 | 2 | 42.28 | 0.28 | 65.0 | 11.4 | 280 | 250 | 243 |
| 85 | 2 | 2 | 38.5 | 0.31 | 71.4 | 10.4 | 255 | 250 | 243 |
| 85 | 2 | 2 | 31.35 | 0.37 | 87.7 | 8.5 | 208 | 250 | 243 |
| 85 | 2 | 2 | 26.94 | 0.44 | 102.1 | 7.3 | 178 | 250 | 243 |
| 85 | 2 | 2 | 20.27 | 0.58 | 135.7 | 5.5 | 134 | 250 | 243 |
| 85 | 2 | 2 | 14.44 | 0.81 | 190.4 | 3.9 | 96 | 250 | 243 |
| 85 | 2 | 2 | 11.23 | 1.04 | 244.9 | 3.0 | 74 | 250 | 243 |
| 85 | 2 | 1 | 8.25 | 1.42 | 333.3 | 2.4 | 58 | 250 | 243 |
| 85 | 2 | 1 | 4.71 | 2.49 | 583.9 | 1.3 | 33 | 250 | 243 |
| 110 | 2 | 3 | 119.83 | 0.10 | 23.0 | 39.2 | 961 | 269 | 262 |
| 110 | 2 | 3 | 103.89 | 0.11 | 26.5 | 34.0 | 833 | 269 | 262 |
| 110 | 2 | 3 | 85.34 | 0.14 | 32.2 | 27.9 | 684 | 269 | 262 |
| 110 | 2 | 2 | 62.7 | 0.19 | 43.9 | 21.4 | 526 | 250 | 243 |
| 110 | 2 | 2 | 53.63 | 0.22 | 51.3 | 18.3 | 450 | 250 | 243 |
| 110 | 2 | 2 | 42.28 | 0.28 | 65.0 | 14.5 | 355 | 250 | 243 |
| 110 | 2 | 2 | 38.5 | 0.31 | 71.4 | 13.2 | 323 | 250 | 243 |
| 110 | 2 | 2 | 31.35 | 0.37 | 87.7 | 10.7 | 263 | 250 | 243 |
| 110 | 2 | 2 | 26.94 | 0.44 | 102.1 | 9.2 | 226 | 250 | 243 |
| 110 | 2 | 2 | 20.27 | 0.58 | 135.7 | 6.9 | 170 | 250 | 243 |
| 110 | 2 | 2 | 14.44 | 0.81 | 190.5 | 4.9 | 121 | 250 | 243 |
| 110 | 2 | 2 | 11.23 | 1.05 | 244.9 | 3.8 | 94 | 250 | 243 |
| 110 | 2 | 1 | 8.25 | 1.42 | 333.4 | 3.0 | 73 | 250 | 243 |
| 110 | 2 | 1 | 4.71 | 2.49 | 583.9 | 1.7 | 42 | 250 | 243 |

For applications with positive driven belts or applications without belt, this combination of motor and gear box is not recommended.

- P_N = Rated power
- np = Number of poles
- gs = Gear stages
- i = Speed ratio
- v = Speed
- n_A = Shell rated speed
- M_A = Drum motor rated torque
- F_N = Drum motor rated belt pull
- M_{MAX}/M_A = Ratio of max. acceleration torque to rated torque
- FW_{MIN} = Minimum drum width
- SL_{MIN} = Minimum shell length

Mechanical data for 1-phase asynchronous motor with technopolymer gear

| P_N [W] | np | gs | i | v [m/s] | n_A [1/min] | M_A [Nm] | F_N [N] | FW_{MIN} [mm] | SL_{MIN} [mm] |
|--------------|----|----|-------|------------|------------------|---------------|--------------|--------------------|--------------------|
| 25 | 4 | 3 | 115.2 | 0.05 | 11.5 | 17.8 | 436 | 287 | 280 |
| 25 | 4 | 3 | 96 | 0.06 | 13.8 | 14.8 | 364 | 287 | 280 |
| 25 | 4 | 3 | 78.55 | 0.07 | 16.8 | 12.1 | 297 | 287 | 280 |
| 25 | 4 | 3 | 71.56 | 0.08 | 18.4 | 11 | 271 | 287 | 280 |
| 75 | 2 | 3 | 96 | 0.12 | 28.6 | 21.4 | 525 | 287 | 280 |
| 75 | 2 | 3 | 78.55 | 0.15 | 35 | 17.5 | 430 | 287 | 280 |
| 75 | 2 | 3 | 71.56 | 0.16 | 38.4 | 16 | 391 | 287 | 280 |
| 75 | 2 | 3 | 63.51 | 0.19 | 43.3 | 14.2 | 347 | 287 | 280 |
| 85 | 2 | 3 | 78.55 | 0.15 | 35 | 20.2 | 496 | 287 | 280 |
| 85 | 2 | 3 | 71.56 | 0.16 | 38.4 | 18.4 | 452 | 287 | 280 |
| 85 | 2 | 3 | 63.51 | 0.19 | 43.3 | 16.3 | 401 | 287 | 280 |
| 110 | 2 | 3 | 63.51 | 0.19 | 43.3 | 20.7 | 508 | 287 | 280 |
| 110 | 2 | 3 | 52.92 | 0.22 | 52 | 17.2 | 423 | 287 | 280 |
| 110 | 2 | 3 | 48.79 | 0.24 | 56.4 | 15.9 | 390 | 287 | 280 |
| 110 | 2 | 3 | 43.3 | 0.27 | 63.5 | 14.1 | 346 | 287 | 280 |
| 110 | 2 | 2 | 19.2 | 0.61 | 143.2 | 6.6 | 162 | 287 | 280 |
| 110 | 2 | 2 | 16 | 0.73 | 171.9 | 5.5 | 135 | 287 | 280 |
| 110 | 2 | 2 | 13.09 | 0.90 | 210.1 | 4.5 | 110 | 287 | 280 |

For applications with positive driven belts or applications without belt, this combination of motor and gear box is not recommended.

| | |
|---------------------------|---|
| P_N = Rated power | M_A = Drum motor rated torque |
| np = Number of poles | F_N = Drum motor rated belt pull |
| gs = Gear stages | M_{MAX}/M_A = Ratio of max. acceleration torque to rated torque |
| i = Speed ratio | FW_{MIN} = Minimum drum width |
| v = Speed | SL_{MIN} = Minimum shell length |
| n_A = Shell rated speed | |

Electrical data for 1-phase asynchronous motor

| P_N [W] | np | U_N [V] | I_N [A] | cosφ | η | J_R [kgcm ²] | I_S/I_N | M_S/M_N | M_B/M_N | M_P/M_N | R_M [Ω] | U_{SH-} [V DC] | C_R [μF] |
|--------------|----|--------------|--------------|------|------|-------------------------------|-----------|-----------|-----------|-----------|--------------|---------------------|---------------|
| 25 | 4 | 230 | 0.39 | 1.00 | 0.28 | 1.2 | 2.2 | 1.11 | 1.37 | 1.11 | 150.0 | 44 | 3 |
| 50 | 2 | 230 | 0.54 | 1.00 | 0.4 | 0.9 | 3.1 | 0.94 | 1.71 | 0.94 | 82.0 | 33 | 3 |
| 75 | 2 | 230 | 0.68 | 1.00 | 0.48 | 1.0 | 3.2 | 0.74 | 1.37 | 0.74 | 66.0 | 34 | 4 |
| 85 | 2 | 230 | 0.73 | 0.98 | 0.53 | 1.3 | 5.2 | 0.93 | 1.6 | 0.93 | 52.0 | 28 | 6 |
| 110 | 2 | 230 | 0.94 | 1.00 | 0.51 | 1.2 | 2.0 | 0.73 | 1.15 | 0.73 | 51.0 | 36 | 8 |

| | |
|---------------------------------|--|
| P_N = Rated power | I_S/I_N = Ratio of startup current - rated current |
| np = Number of poles | M_S/M_N = Ratio of startup torque - rated torque |
| U_N = Rated voltage | M_B/M_N = Ratio of pull-out torque - rated torque |
| I_N = Rated current | M_P/M_N = Ratio of pull-up torque - rated torque |
| cosφ = Power factor | R_M = Branch resistance |
| η = Efficiency | U_{SH-} = Heater voltage for DC units |
| J_R = Rotor moment of inertia | C_R = Capacitor size |

Belt tension diagrams

Belt tension depending on drum width

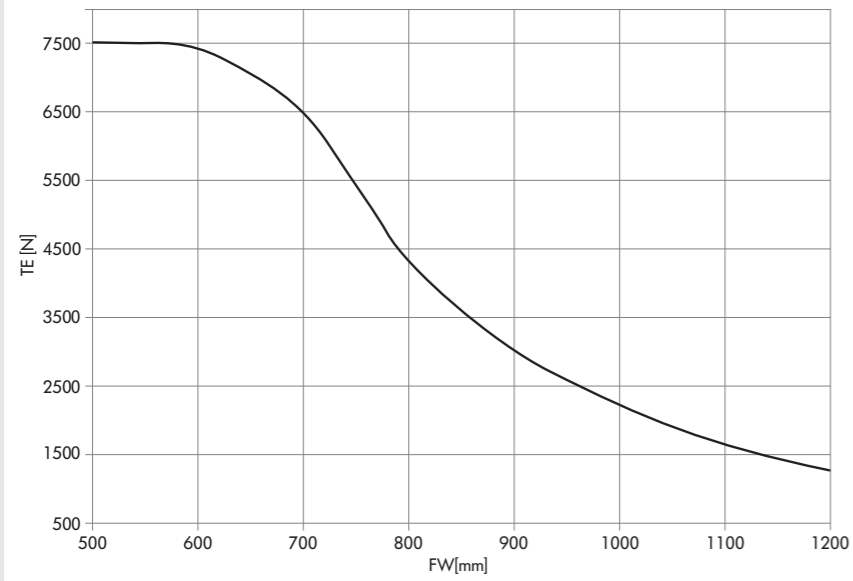

Belt tension depending on rated speed of shell

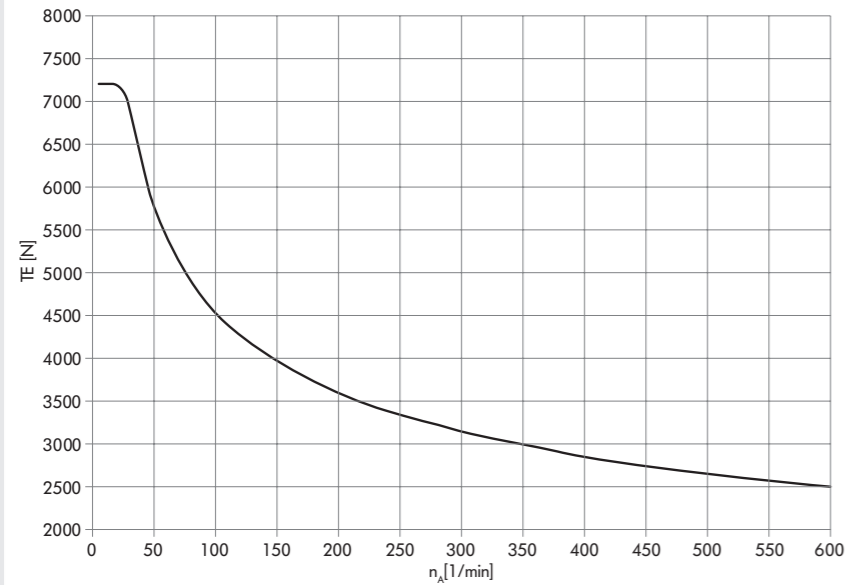

Note: The correct value for the maximum permissible belt tension is determined from the speed of the drum motor. When selecting the motor, also check whether the maximum permissible TE value fits the desired drum width (FW).

- TE = Belt tension
- n_A = Shell rated speed
- FW = Drum width

Dimensions

Drum motor

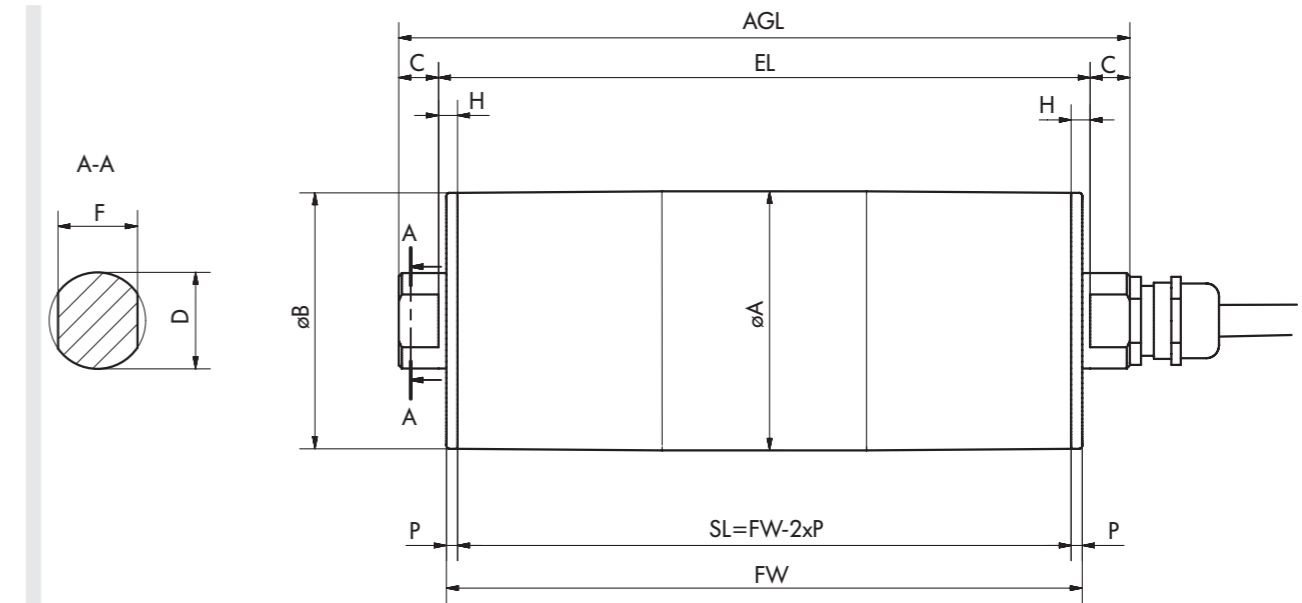

| Type | A [mm] | B [mm] | C [mm] | D [mm] | F [mm] | H [mm] | P [mm] | SL [mm] | EL [mm] | AGL [mm] |
|----------------------------------|--------|--------|--------|--------|--------|--------|--------|---------|---------|----------|
| DM 0080 crowned | 81.5 | 80.5 | 12.5 | 30 | 25 | 6 | 3.5 | FW - 7 | FW + 5 | FW + 30 |
| | 81.5 | 80.5 | 12.5 | 25 | 20 | 6 | 3.5 | FW - 7 | FW + 5 | FW + 30 |
| | 81.5 | 80.5 | 12.5 | 17 | 13.5 | 6 | 3.5 | FW - 7 | FW + 5 | FW + 30 |
| DM 0080 cylindrical | 81 | 81 | 12.5 | 30 | 25 | 6 | 3.5 | FW - 7 | FW + 5 | FW + 30 |
| | 81 | 81 | 12.5 | 25 | 20 | 6 | 3.5 | FW - 7 | FW + 5 | FW + 30 |
| | 81 | 81 | 12.5 | 17 | 13.5 | 6 | 3.5 | FW - 7 | FW + 5 | FW + 30 |
| DM 0080 cylindrical + key | 81.7 | 81.7 | 12.5 | 30 | 25 | 6 | 3.5 | FW - 7 | FW + 5 | FW + 30 |
| | 81.7 | 81.7 | 12.5 | 25 | 20 | 6 | 3.5 | FW - 7 | FW + 5 | FW + 30 |
| | 81.7 | 81.7 | 12.5 | 17 | 13.5 | 6 | 3.5 | FW - 7 | FW + 5 | FW + 30 |

Practice-oriented, scalable and thought out in detail: The new drum motor DM 0113 makes it easy to build a completely individual conveyor system and is dimensioned for the higher requirements for permissible belt tension from industry and belt manufacturers.

With a broader speed spectrum, the DM 0113 covers all possible applications. The clever plug-and-play connection significantly simplifies the installation. Each motor is approved, tested, and modularized so that it can be produced and delivered around the world in the shortest amount of time.

The modular design of the DM 0113 allows a free combination of individual module groups, such as shaft, end cover, shell or steel gear, asynchronous or synchronous motor winding, to perfectly meet the requirements of an application. In addition, various options, such as encoder, brake, backstop, rubber laggings, etc., as well as different accessories are available.

With the platform concept of the DM 0113, it is possible to cover all internal logistics applications in the food processing sector, as well as in industry, distribution and airports.



Technical data

| | Asynchronous squirrel cage motor | AC synchronous permanent magnet motor |
|--|--|---|
| Insulation class of motor windings | Class F, IEC 34 (VDE 0530) | Class F, IEC 34 (VDE 0530) |
| Voltage | 230/400 V ±5 % (IEC 34/38) Most of the common international voltages and frequencies are available upon request | 230 or 400 V |
| Frequency | 50 Hz | 150 Hz |
| Shaft seal, internal | NBR | NBR |
| Protection rate | IP69K | IP69K |
| Thermal protection | Bi-metal switch | Bi-metal switch |
| Operating mode | S1 | S1 |
| Ambient temperature, 3-phase motor | +2 to +40 °C Low temperature ranges on request | +2 to +40 °C Low temperature ranges on request |
| Ambient temperature, 3-phase motor for applications with positive driven belts or no belt | +2 to +25 °C | +2 to +40 °C |

Design variants and accessories

| | |
|--------------------|---|
| Laggings | Lagging for friction drive belts Lagging for modular plastic belts Lagging for positive drive solid homogeneous belts |
| Sprockets | Sprockets for modular plastic belts |
| Options | Backstop Electromagnetic holding brake and rectifier Feedback devices Balancing Plug connection |
| Oils | Food-grade oils (EU, FDA) |
| Certificate | cULus safety certificates (starting Q1/2019) |
| Accessories | Idler pulleys; conveyor rollers; mounting brackets; cables; inverters |

A combination of encoder and safety holding brake is not possible. In addition, the use of a backstop with a synchronous motor is technically not meaningful.

Material variants

The following components can be selected for the drum motor and the electrical connection.
The combination of components depends on the material used.

| Component | Version | Aluminum | Mild steel | Stainless steel | Brass/nickel | Technopolymer |
|-----------------------------|---------------------------------|----------|------------|-----------------|--------------|---------------|
| Shell | Crowned | | ● | ● | | |
| | Cylindrical | | ● | ● | | |
| | Cylindrical + key for sprockets | | ● | ● | | |
| End housing | Standard | ● | | ● | | |
| Shaft | Standard | | ● | ● | | |
| | Cross-drilled thread | | ● | ● | | |
| Gear boxes | Planetary gear box | | ● | | | |
| Electrical connector | Straight connector | | | ● | ● | ● |
| | Straight hygienic connector | | | ● | | |
| | Elbow connector | | | ● | | ● |
| | Terminal box | ● | | ● | | |
| | Straight plug connection | | | ● | | |
| Motor winding | Asynchronous motor | | | | | |
| | Synchronous motor | | | | | |
| External seal | PTFE | | | | | |

Motor variants

Mechanical data for synchronous motors with steel gear

| P _N [W] | np | gs | i | v [m/s] | n _A [min ⁻¹] | M _A [Nm] | F _N [N] | M _{MAX} /M _A | FW _{MIN} [mm] | SL _{MIN} [mm] |
|-----------------------|----|----|-----|------------|--|------------------------|-----------------------|----------------------------------|---------------------------|---------------------------|
| 300 | 4 | 3 | 168 | 0.16 | 26.8 | 91.7 | 1623 | 1.5 | 227 | 220 |
| 300 | 4 | 3 | 120 | 0.22 | 37.5 | 65.5 | 1159 | 2.1 | 227 | 220 |
| 300 | 4 | 3 | 100 | 0.27 | 45.0 | 54.6 | 966 | 2.5 | 227 | 220 |
| 300 | 4 | 3 | 80 | 0.33 | 56.3 | 43.7 | 773 | 3 | 227 | 220 |
| 300 | 4 | 2 | 63 | 0.42 | 71.4 | 36.2 | 641 | 3 | 207 | 200 |
| 300 | 4 | 2 | 45 | 0.59 | 100 | 25.9 | 458 | 3 | 207 | 200 |
| 300 | 4 | 2 | 36 | 0.74 | 125 | 20.7 | 366 | 3 | 207 | 200 |
| 300 | 4 | 2 | 30 | 0.89 | 150 | 17.2 | 305 | 3 | 207 | 200 |
| 300 | 4 | 2 | 24 | 1.11 | 187.5 | 13.8 | 244 | 3 | 207 | 200 |
| 300 | 4 | 2 | 20 | 1.33 | 225 | 11.5 | 203 | 3 | 207 | 200 |
| 300 | 4 | 2 | 16 | 1.66 | 281.3 | 9.2 | 163 | 3 | 207 | 200 |
| 300 | 4 | 2 | 12 | 2.22 | 375 | 6.9 | 122 | 3 | 207 | 200 |
| 300 | 4 | 1 | 9 | 2.96 | 500 | 5.4 | 96 | 3 | 207 | 200 |
| 700 | 4 | 3 | 80 | 0.33 | 56.3 | 101.9 | 1803 | 1.3 | 257 | 250 |
| 700 | 4 | 2 | 63 | 0.42 | 71.4 | 84.5 | 1495 | 1.7 | 237 | 230 |
| 700 | 4 | 2 | 45 | 0.59 | 100 | 60.3 | 1068 | 2.4 | 237 | 230 |
| 700 | 4 | 2 | 36 | 0.74 | 125 | 48.3 | 854 | 3 | 237 | 230 |
| 700 | 4 | 2 | 30 | 0.89 | 150 | 40.2 | 712 | 3 | 237 | 230 |
| 700 | 4 | 2 | 24 | 1.11 | 187.5 | 32.2 | 569 | 3 | 237 | 230 |
| 700 | 4 | 2 | 20 | 1.33 | 225 | 26.8 | 475 | 3 | 237 | 230 |
| 700 | 4 | 2 | 16 | 1.66 | 281.3 | 21.4 | 380 | 3 | 237 | 230 |
| 700 | 4 | 2 | 12 | 2.22 | 375 | 16.1 | 285 | 3 | 237 | 230 |
| 700 | 4 | 1 | 9 | 2.96 | 500 | 12.7 | 225 | 3 | 237 | 230 |

| P_N [W] | np | gs | i | v [m/s] | n_A [min ⁻¹] | M_A [Nm] | F_N [N] | M_{MAX}/M_A | FW_{MIN} [mm] | SL_{MIN} [mm] |
|--------------|----|----|----|------------|-------------------------------|---------------|--------------|---------------|--------------------|--------------------|
| 1100 | 4 | 2 | 63 | 0.42 | 71.4 | 132.7 | 2349 | 1.1 | 267 | 260 |
| 1100 | 4 | 2 | 45 | 0.59 | 100 | 94.8 | 1678 | 1.5 | 267 | 260 |
| 1100 | 4 | 2 | 36 | 0.74 | 125 | 75.8 | 1342 | 1.9 | 267 | 260 |
| 1100 | 4 | 2 | 30 | 0.89 | 150 | 63.2 | 1119 | 2.3 | 267 | 260 |
| 1100 | 4 | 2 | 24 | 1.11 | 187.5 | 50.6 | 895 | 2.8 | 267 | 260 |
| 1100 | 4 | 2 | 20 | 1.33 | 225 | 42.1 | 746 | 3 | 267 | 260 |
| 1100 | 4 | 2 | 16 | 1.66 | 281.3 | 33.7 | 597 | 3 | 267 | 260 |
| 1100 | 4 | 2 | 12 | 2.22 | 375 | 25.3 | 447 | 3 | 267 | 260 |
| 1100 | 4 | 1 | 9 | 2.96 | 500 | 20.0 | 353 | 3 | 267 | 260 |

- P_N = Rated power
- np = Number of poles
- gs = Gear stages
- i = Speed ratio
- v = Speed
- n_A = Shell rated speed
- M_A = Drum motor rated torque
- F_N = Drum motor rated belt pull
- M_{MAX}/M_A = Ratio of max. acceleration torque to rated torque
- FW_{MIN} = Minimum drum width
- SL_{MIN} = Minimum shell length

Electrical data for synchronous motors

| P_N [W] | np | U_N [V] | I_N [A] | I_0 [A] | I_{MAX} [A] | f_N [Hz] | η | n_N [rpm] | J_R [kgcm ²] | M_N [Nm] | M_0 [Nm] | M_{MAX} [Nm] | R_M [Ω] | L_{SD} [mH] | L_{SQ} [mH] | k_e [V/krpm] | T_e [ms] | k_{TN} [Nm/A] | U_{SH} [V] |
|--------------|----|--------------|--------------|--------------|------------------|---------------|--------|----------------|-------------------------------|---------------|---------------|-------------------|--------------|------------------|------------------|-------------------|---------------|--------------------|-----------------|
| 300 | 4 | 230 | 1.3 | 1.3 | 3.9 | 150 | 0.88 | 4500 | 0.01 | 0.64 | 0.64 | 1.91 | 16.1 | 68.67 | 101.33 | 40.41 | 12.59 | 0.49 | 31 |
| 300 | 4 | 400 | 0.75 | 0.75 | 2.25 | 150 | 0.88 | 4500 | 0.01 | 0.64 | 0.64 | 1.91 | 48.3 | 206.0 | 304.0 | 69.99 | 12.59 | 0.85 | 54 |
| 700 | 4 | 230 | 2.91 | 2.91 | 8.73 | 150 | 0.91 | 4500 | 0.02 | 1.49 | 1.49 | 4.46 | 3.8 | 26.47 | 38.93 | 39.57 | 20.49 | 0.51 | 17 |
| 700 | 4 | 400 | 1.68 | 1.68 | 5.04 | 150 | 0.91 | 4500 | 0.02 | 1.49 | 1.49 | 4.46 | 11.4 | 79.40 | 116.8 | 68.54 | 20.49 | 0.88 | 29 |
| 1100 | 4 | 230 | 3.62 | 3.62 | 10.86 | 150 | 0.92 | 4500 | 0.04 | 2.33 | 2.33 | 7.0 | 2.37 | 19.27 | 28.40 | 42.77 | 24.00 | 0.64 | 13 |
| 1100 | 4 | 400 | 2.09 | 2.09 | 6.27 | 150 | 0.92 | 4500 | 0.04 | 2.33 | 2.33 | 7.0 | 7.1 | 57.80 | 85.20 | 74.08 | 24.00 | 1.12 | 22 |

- P_N = Rated power
- np = Number of poles
- U_N = Rated voltage
- I_N = Rated current
- I_0 = Standstill current
- I_{MAX} = Maximum current
- f_N = Rated frequency
- η = Efficiency
- n_N = Rated torque of rotor
- J_R = Rotor moment of inertia
- M_N = Rated torque of rotor
- M_0 = Standstill torque
- M_{MAX} = Maximum torque
- R_M = Phase to phase resistance
- L_{SD} = d-axis inductance
- L_{SQ} = q-axis inductance
- k_e = EMF (mutual induction voltage constant)
- T_e = Electrical time constant
- k_{TN} = Torque constant
- U_{SH} = Heating voltage

Mechanical data for 3-phase asynchronous motor with steel gear

| P_N [W] | np | gs | i | v [m/s] | n_A [min ⁻¹] | M_A [Nm] | F_N [N] | FW_{MIN} [mm] | SL_{MIN} [mm] |
|--------------|----|----|------|------------|-------------------------------|---------------|--------------|--------------------|--------------------|
| 160 | 4 | 3 | 168 | 0.05 | 8.3 | 157 | 2779 | 307 | 300 |
| 160 | 4 | 3 | 150 | 0.06 | 9.3 | 140.2 | 2481 | 307 | 300 |
| 160 | 4 | 3 | 120 | 0.07 | 11.6 | 112.1 | 1985 | 307 | 300 |
| 160 | 4 | 2 | 73.8 | 0.11 | 18.9 | 72.6 | 1285 | 257 | 250 |
| 160 | 4 | 2 | 63 | 0.13 | 22.2 | 62 | 1097 | 257 | 250 |
| 160 | 4 | 2 | 45 | 0.18 | 31 | 44.3 | 783 | 257 | 250 |
| 160 | 4 | 2 | 36 | 0.23 | 38.8 | 35.4 | 627 | 257 | 250 |
| 160 | 4 | 2 | 30 | 0.28 | 46.6 | 29.5 | 533 | 257 | 250 |
| 160 | 4 | 2 | 27 | 0.31 | 51.7 | 26.6 | 470 | 257 | 250 |
| 160 | 4 | 2 | 24 | 0.34 | 58.2 | 23.6 | 418 | 257 | 250 |
| 160 | 4 | 2 | 20 | 0.41 | 69.9 | 19.7 | 348 | 257 | 250 |
| 160 | 4 | 2 | 16 | 0.52 | 87.3 | 15.7 | 279 | 257 | 250 |
| 160 | 4 | 2 | 12 | 0.69 | 116.4 | 11.8 | 209 | 257 | 250 |
| 160 | 4 | 1 | 9 | 0.92 | 155.2 | 9.3 | 165 | 257 | 250 |
| 225 | 2 | 2 | 73.8 | 0.22 | 37.4 | 52 | 919 | 257 | 250 |
| 225 | 2 | 2 | 63 | 0.26 | 43.8 | 44.3 | 785 | 257 | 250 |
| 225 | 2 | 2 | 45 | 0.36 | 61.3 | 31.7 | 561 | 257 | 250 |
| 225 | 2 | 2 | 36 | 0.45 | 76.6 | 25.3 | 449 | 257 | 250 |
| 225 | 2 | 2 | 30 | 0.54 | 91.9 | 21.1 | 374 | 257 | 250 |
| 225 | 2 | 2 | 27 | 0.6 | 102.1 | 19 | 336 | 257 | 250 |
| 225 | 2 | 2 | 24 | 0.68 | 114.9 | 16.9 | 299 | 257 | 250 |
| 225 | 2 | 2 | 20 | 0.82 | 137.9 | 14.1 | 249 | 257 | 250 |
| 225 | 2 | 1 | 16 | 1.02 | 172.4 | 11.3 | 199 | 257 | 250 |
| 255 | 2 | 2 | 12 | 1.36 | 229.8 | 8.4 | 150 | 257 | 250 |
| 255 | 2 | 1 | 9 | 1.81 | 306.4 | 6.7 | 118 | 257 | 250 |
| 370 | 4 | 2 | 63 | 0.13 | 22 | 145 | 2566 | 307 | 300 |
| 370 | 4 | 2 | 45 | 0.18 | 30.8 | 103.6 | 1833 | 307 | 300 |
| 370 | 4 | 2 | 36 | 0.23 | 38.6 | 82.8 | 1466 | 307 | 300 |
| 370 | 4 | 2 | 30 | 0.27 | 46.3 | 69 | 1222 | 307 | 300 |
| 370 | 4 | 2 | 27 | 0.3 | 51.4 | 62.1 | 1100 | 307 | 300 |
| 370 | 4 | 2 | 24 | 0.34 | 57.8 | 55.2 | 978 | 307 | 300 |
| 370 | 4 | 2 | 20 | 0.41 | 69.4 | 46 | 815 | 307 | 300 |

| P_N [W] | np | gs | i | v [m/s] | n_A [min ⁻¹] | M_A [Nm] | F_N [N] | FW_{MIN} [mm] | SL_{MIN} [mm] |
|--------------|----|----|------|------------|-------------------------------|---------------|--------------|--------------------|--------------------|
| 370 | 4 | 2 | 16 | 0.51 | 86.8 | 36.8 | 652 | 307 | 300 |
| 370 | 4 | 2 | 12 | 0.68 | 115.7 | 27.6 | 489 | 307 | 300 |
| 370 | 4 | 1 | 9 | 0.91 | 154.2 | 21.8 | 386 | 307 | 300 |
| 370 | 2 | 2 | 73.8 | 0.22 | 37.7 | 84.6 | 1497 | 307 | 300 |
| 370 | 2 | 2 | 45 | 0.37 | 61.8 | 51.6 | 913 | 307 | 300 |
| 370 | 2 | 2 | 36 | 0.46 | 77.2 | 41.3 | 730 | 307 | 300 |
| 370 | 2 | 2 | 30 | 0.55 | 92.6 | 34.4 | 609 | 307 | 300 |
| 370 | 2 | 2 | 27 | 0.61 | 102.9 | 30.9 | 548 | 307 | 300 |
| 370 | 2 | 2 | 20 | 0.82 | 139 | 22.9 | 406 | 307 | 300 |
| 370 | 2 | 2 | 16 | 1.03 | 173.7 | 18.3 | 325 | 307 | 300 |
| 370 | 2 | 1 | 9 | 1.83 | 308.8 | 10.9 | 192 | 307 | 300 |
| 550 | 2 | 2 | 36 | 0.46 | 78.1 | 60.8 | 1075 | 317 | 310 |
| 550 | 2 | 2 | 30 | 0.55 | 93.8 | 50.6 | 896 | 317 | 310 |
| 550 | 2 | 2 | 27 | 0.62 | 104.2 | 45.6 | 806 | 317 | 310 |
| 550 | 2 | 2 | 24 | 0.69 | 117.2 | 40.5 | 717 | 317 | 310 |
| 550 | 2 | 2 | 20 | 0.83 | 140.7 | 33.8 | 597 | 317 | 310 |
| 550 | 2 | 2 | 16 | 1.04 | 175.8 | 27 | 478 | 317 | 310 |
| 550 | 2 | 2 | 12 | 1.39 | 234.4 | 20.3 | 358 | 317 | 310 |
| 550 | 2 | 1 | 9 | 1.85 | 312.6 | 16 | 283 | 317 | 310 |

For applications with positive driven belts or applications without belt, the power must be reduced by 17 %.

- P_N = Rated power
- np = Number of poles
- gs = Gear stages
- i = Speed ratio
- v = Speed
- n_A = Shell rated speed
- M_A = Drum motor rated torque
- F_N = Drum motor rated belt pull
- FW_{MIN} = Minimum drum width
- SL_{MIN} = Minimum shell length

Electrical data for 3-phase asynchronous motor

| P_N [W] | np | n_N [min ⁻¹] | f_N [Hz] | U_N [V] | I_N [A] | cosφ | η | J_R [kgcm ²] | I_S/I_N | M_S/M_N | M_P/M_N | M_B/M_N | M_N [Nm] | R_M [Ω] | $U_{SHΔ}$ [V] | U_{SHY} [V] |
|--------------|----|-------------------------------|---------------|--------------|--------------|------|------|-------------------------------|-----------|-----------|-----------|-----------|---------------|--------------|------------------|------------------|
| 160 | 4 | 1397 | 50 | 400 | 0.54 | 0.7 | 60.5 | 3.8 | 3.05 | 1.92 | 1.92 | 2.13 | 1.09 | 63.7 | | 36.4 |
| 160 | 4 | 1397 | 50 | 230 | 0.94 | 0.7 | 60.5 | 3.8 | 3.05 | 1.92 | 1.92 | 2.13 | 1.09 | 64 | 21 | |
| 225 | 2 | 2758 | 50 | 400 | 0.56 | 0.86 | 67.8 | 2.5 | 4.32 | 2.57 | 2.57 | 2.62 | 0.78 | 39.3 | | 28.1 |
| 225 | 2 | 2758 | 50 | 230 | 0.96 | 0.86 | 67.8 | 2.5 | 4.32 | 2.57 | 2.57 | 2.62 | 0.78 | 39.3 | 16.2 | |
| 370 | 4 | 1388 | 50 | 400 | 1.1 | 0.71 | 68.0 | 6.8 | 3.67 | 2.35 | 2.29 | 2.43 | 2.55 | 22.1 | | 25.8 |
| 370 | 4 | 1388 | 50 | 230 | 1.9 | 0.71 | 68.0 | 6.8 | 3.67 | 2.35 | 2.29 | 2.43 | 2.55 | 22.1 | 14.9 | |
| 370 | 2 | 2779 | 50 | 400 | 0.82 | 0.87 | 74.2 | 4.4 | 5.47 | 2.91 | 2.88 | 2.91 | 1.27 | 19.9 | | 21.3 |
| 370 | 2 | 2779 | 50 | 230 | 1.42 | 0.87 | 74.2 | 4.4 | 5.47 | 2.91 | 2.88 | 2.91 | 1.27 | 19.9 | 12.3 | |
| 550 | 2 | 2813 | 50 | 400 | 1.23 | 0.85 | 76.5 | 5.4 | 5.77 | 3.27 | 3.15 | 3.27 | 1.87 | 11.6 | | 18.1 |
| 550 | 2 | 2813 | 50 | 230 | 2.13 | 0.85 | 76.5 | 5.4 | 5.77 | 3.27 | 3.15 | 3.27 | 1.87 | 11.6 | 10.5 | |

- P_N = Rated power
- n_p = Number of poles
- n_N = Rated speed of rotor
- f_N = Rated frequency
- U_N = Rated voltage
- I_N = Rated current
- cosφ = Power factor
- η = Efficiency
- J_R = Rotor moment of inertia
- I_S/I_N = Ratio of startup current - rated current
- M_S/M_N = Ratio of startup torque - rated torque
- M_B/M_N = Ratio of pull-out torque - rated torque
- M_P/M_N = Ratio of pull-up torque - rated torque
- M_N = Rated torque of rotor
- R_M = Branch resistance
- $U_{SHΔ}$ = Heater voltage in delta connection
- U_{SHY} = Heater voltage in star connection

Mechanical data for 1-phase asynchronous motor with steel gear

| P_N [W] | np | gs | i | v [m/s] | n_A [1/min] | M_A [Nm] | F_N [N] | FW_{MIN} [mm] | SL_{MIN} [mm] |
|--------------|----|----|----|------------|------------------|---------------|--------------|--------------------|--------------------|
| 250 | 4 | 2 | 45 | 0.18 | 30.2 | 71.5 | 1265 | 307 | 300 |
| 250 | 4 | 2 | 36 | 0.22 | 37.8 | 57.2 | 1012 | 307 | 300 |
| 250 | 4 | 2 | 30 | 0.27 | 45.3 | 47.7 | 843 | 307 | 300 |
| 250 | 4 | 2 | 27 | 0.3 | 50.4 | 42.9 | 759 | 307 | 300 |
| 250 | 4 | 2 | 24 | 0.34 | 56.7 | 38.1 | 675 | 307 | 300 |
| 250 | 4 | 2 | 20 | 0.4 | 68 | 31.8 | 562 | 307 | 300 |
| 250 | 4 | 2 | 16 | 0.5 | 85 | 25.4 | 450 | 307 | 300 |
| 250 | 4 | 2 | 12 | 0.67 | 113.3 | 19.1 | 337 | 307 | 300 |

For applications with positive driven belts or applications without belt, this combination of motor and gear box is not recommended.

- P_N = Rated power
- np = Number of poles
- gs = Gear stages
- i = Speed ratio
- v = Speed
- n_A = Shell rated speed
- M_A = Drum motor rated torque
- F_N = Drum motor rated belt pull
- M_{MAX}/M_A = Ratio of max. acceleration torque to rated torque
- FW_{MIN} = Minimum drum width
- SL_{MIN} = Minimum shell length

Electrical data for 1-phase asynchronous motor

| P_N [W] | np | U_N [V] | I_N [A] | cosφ | η [%] | J_R [kgcm ²] | I_S/I_N | M_S/M_N | M_B/M_N | M_P/M_N | R_M [Ω] | U_{SH-} [V DC] | C_R [μF] |
|--------------|----|--------------|--------------|------|----------|-------------------------------|-----------|-----------|-----------|-----------|--------------|---------------------|---------------|
| 250 | 4 | 1360 | 2.4 | 0.97 | 0.5 | 7.2 | 1.25 | 1.1 | 1.1 | 1.1 | 12.7 | 44.3 | 12 |

- P_N = Rated power
- np = Number of poles
- U_N = Rated voltage
- I_N = Rated current
- cosφ = Power factor
- η = Efficiency
- J_R = Rotor moment of inertia
- I_S/I_N = Ratio of startup current - rated current
- M_S/M_N = Ratio of startup torque - rated torque
- M_B/M_N = Ratio of pull-out torque - rated torque
- M_P/M_N = Ratio of pull-up torque - rated torque
- R_M = Branch resistance
- U_{SH-} = Heater voltage for DC units
- C_R = Capacitor size

Belt tension diagrams

Belt tension depending on drum width

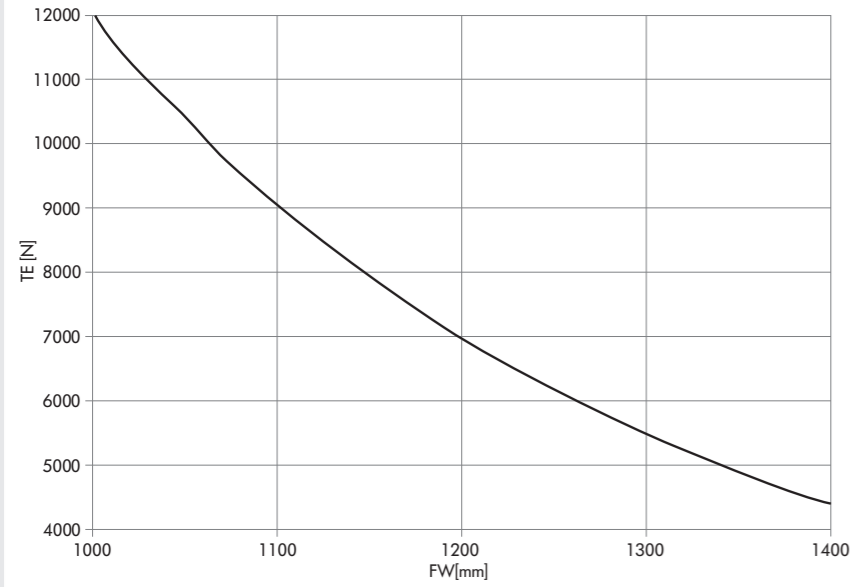

Belt tension depending on rated speed of shell

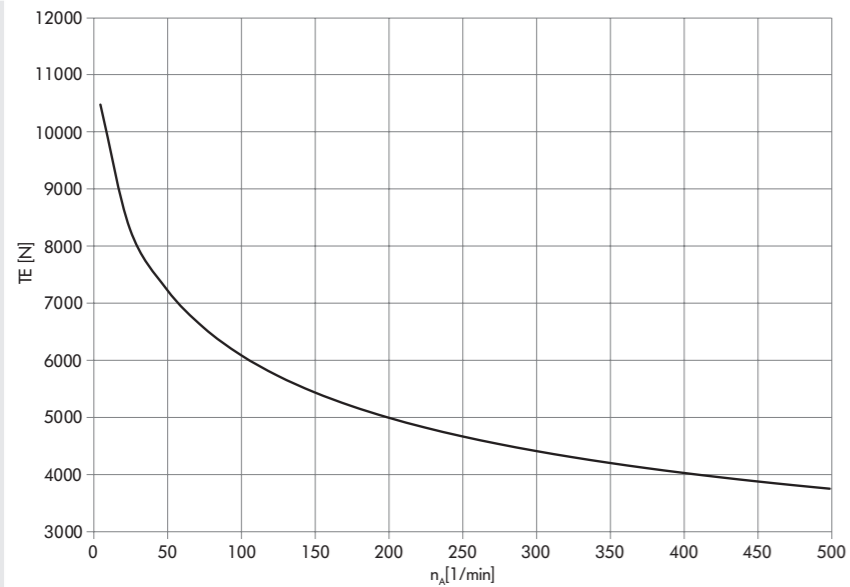

Note: The correct value for the maximum permissible belt tension is determined from the speed of the drum motor. When selecting the motor, also check whether the maximum permissible TE value fits the desired drum width (FW).

- TE = Belt tension
- n_A = Shell rated speed
- FW = Drum width

Dimensions

Drum motor

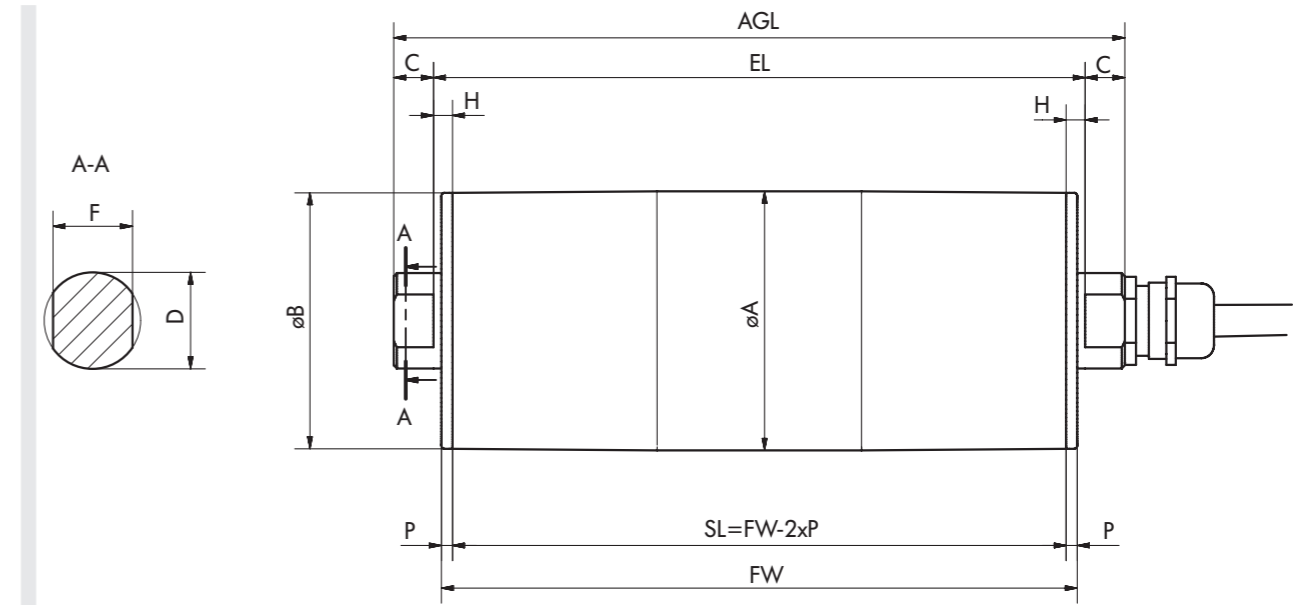

| Type | A [mm] | B [mm] | C [mm] | D [mm] | F [mm] | H [mm] | P [mm] | SL [mm] | EL [mm] | AGL [mm] |
|---------------------------|--------|--------|--------|--------|--------|--------|--------|---------|---------|----------|
| DM 0113 crowned | 113 | 112 | 25 | 30 | 25 | 10 | 3.5 | FW - 7 | FW + 13 | FW + 63 |
| | 113 | 112 | 25 | 25* | 20 | 10 | 3.5 | FW - 7 | FW + 13 | FW + 63 |
| DM 0113 cylindrical | 112 | 112 | 25 | 30 | 25 | 10 | 3.5 | FW - 7 | FW + 13 | FW + 63 |
| | 112 | 112 | 25 | 25* | 20 | 10 | 3.5 | FW - 7 | FW + 13 | FW + 63 |
| DM 0113 cylindrical + key | 113 | 113 | 25 | 30 | 25 | 10 | 3.5 | FW - 7 | FW + 13 | FW + 63 |
| | 113 | 113 | 25 | 25* | 20 | 10 | 3.5 | FW - 7 | FW + 13 | FW + 63 |

* Available from Q4/2018

Cable overview

Cable connections

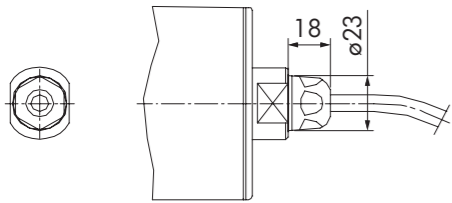

Fig.: Straight hygienic connector, IP69k stainless steel

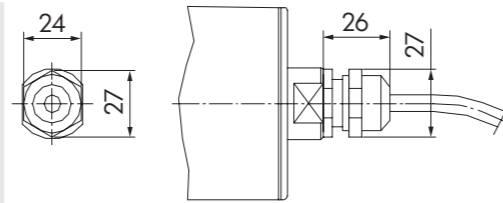

Fig.: Straight connector, brass or stainless steel

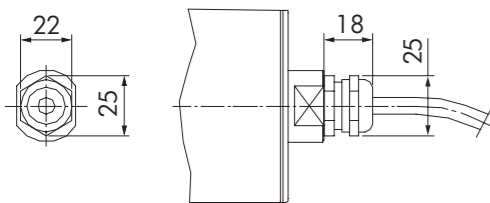

Fig.: Straight EMC connector, brass or stainless steel

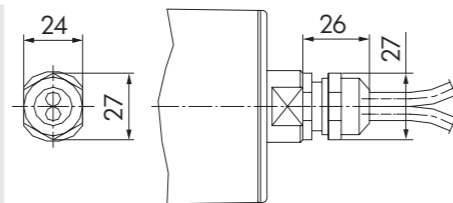

Fig.: Straight connector for encoder, brass or stainless steel

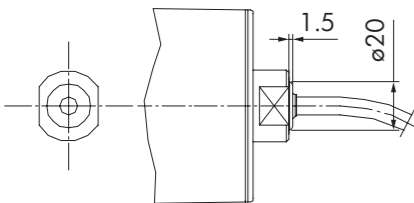

Fig.: Straight connector, shaft cap made of PU

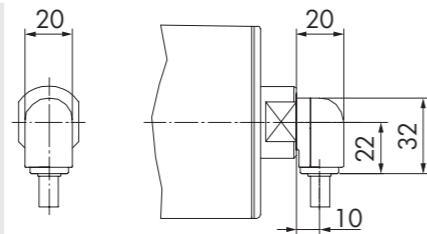

Fig.: Elbow connector, Technopolymer

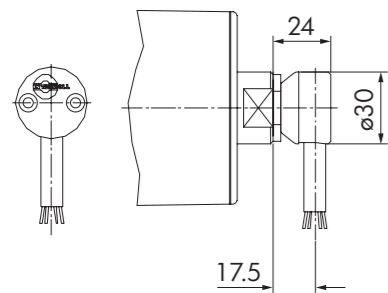

Fig.: Elbow connector, stainless steel, also for encoders

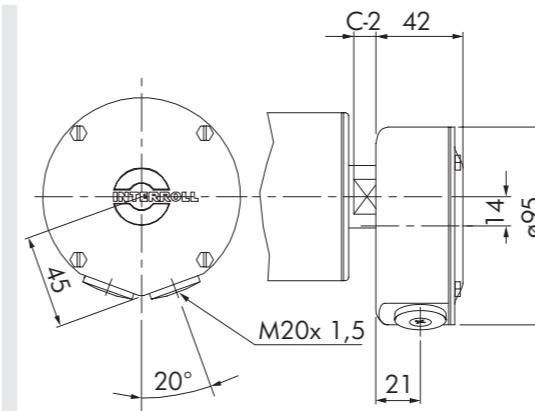

Fig.: Terminal box, stainless steel

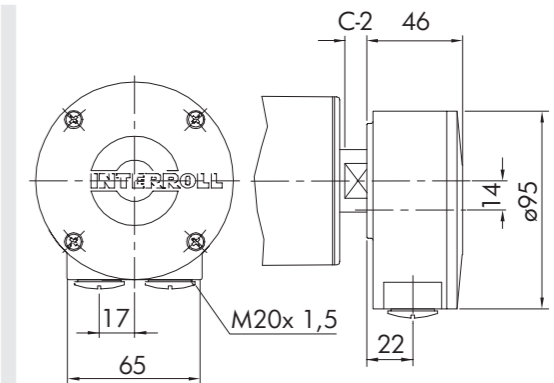

Fig.: Terminal box, aluminum

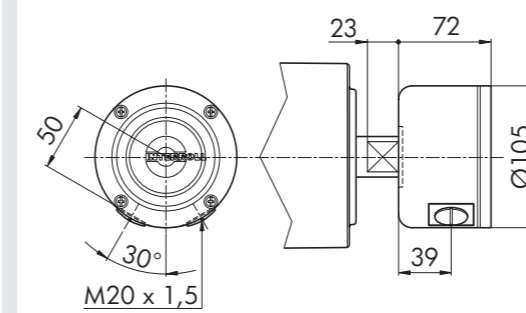

Fig.: DM 0113, terminal box, technopolymer

The minimum length of the drum motor with options increases as follows:

| | |
|--------------------------|---------------------|
| Brake: | Min. FW + 59 mm |
| Feedback device: | Min. FW + 50 mm |
| Cable specification: | page 43 |
| Available cable lengths: | 1 m, 3 m, 5 m, 10 m |

Straight plug connection (hygienic design)

The new plug connection is the ideal solution for a quick initial installation and significantly less maintenance effort. Connecting and disconnecting the cables to the motor is simple and can be performed safely and very quickly in just a few steps. Complete disassembly is not needed for motor maintenance or the replacement of a damaged cable. Only the pressing screw and the shell nipple must be loosened and completely unscrewed from the shaft end. Then the connector can easily be pulled out. The assembly is just as simple, in reverse order: The connector engages in the intended position. Then the shell nipple and pressing screw are screwed in and firmly tightened to the block.

Technical data

| | |
|----------------------------|---|
| Shaft design | Only for 30 mm shaft diameter and 25 mm width across flats |
| Materials | Stainless steel, TPU seals |
| Connection | Star/delta configuration with thermal controller contact (shield optional) |
| Cable lengths | 1 m, 3 m, 5 m, 10 m |
| Delivery | Cable not installed, screw components installed on cable |
| Electrical data | According to DIN EN 61984 |
| Voltage | 230/400 V |
| Amperage | Max. 5 A |
| Temperature range | +2 to +40 °C Lower temperatures on request |
| Protection rate | IP69k after complete assembly |
| Hygiene requirement | Suitable for cleaning with high-pressure cleaner |
| Directives | CE certified, EHEDG certified, use of chemicals permissible according to ECOLAB |
| Mounting tool | Open-end wrench 14 mm and 20 mm |

The minimum length of the drum motor with plug connection increases by 59 mm.

Dimensions

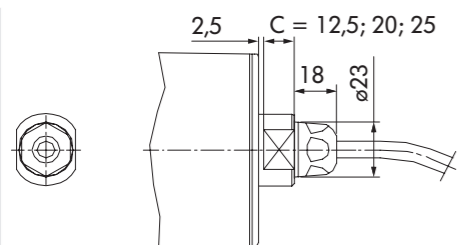

Fig.: Straight plug connection, qualified for hygienic cleaning, IP69k, stainless steel

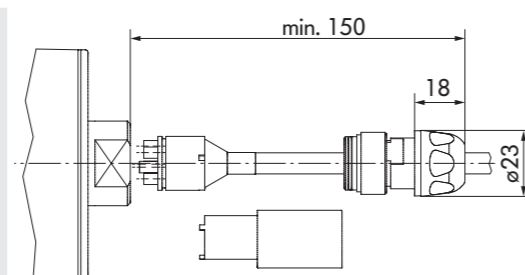

Fig.: Mounting dimensions with a mounting tool

Cable types

To reduce EMC emissions, please use a shielded cable for operating the motor via a frequency inverter .

| Article number | 1107481 | 1107478 | 1107477 | 1107479 | 1107480 | 1107482 | 1000569 |
|---|--------------------------------|--------------------------------|--------------------------------|---------------------------|--------------------------------|---------------------------|---|
| Main cores (number) | 7 | 7 | 7 | 7 | 4 | 4 | 7 |
| Cross section | 0.5 mm ² | 0.75 mm ² | 0.75 mm ² | 0.75 mm ² | 0.75 mm ² | 0.75 mm ² | 0.75 mm ² |
| Numeric code and color code | Numeric code + color code | Numeric code + color code | Numeric code + color code | Numeric code + color code | Numeric code + color code | Numeric code + color code | Numeric code + color code |
| Insulation conductors (main cores) | ETFE | ETFE | ETFE | PP | ETFE | PP | PVC |
| Data cores (number) | 2 | 2 | 2 | 2 | 2 | 2 | – |
| Cross section | 0.5 mm ² | 0.5 mm ² | 0.5 mm ² | 0.5 mm ² | 0.5 mm ² | 0.5 mm ² | – |
| Numeric code and color code | Color code | Color code | Color code | Color code | Color code | Color code | – |
| Insulation conductors (data cores) | ETFE | ETFE | ETFE | PP | ETFE | PP | – |
| Insulation of outer sheath | PVC | PVC | PVC | TPU | PVC | TPU | PVC |
| Halogen-free | No | No | No | Yes | No | Yes | No |
| Color of outer sheath | Gray | Gray | Gray | Gray | Gray | Gray | Black |
| Shielded | Copper-tinned | Copper-tinned | – | Copper-tinned | Copper-tinned | Copper-tinned | – |
| Outside diameter | 7.7 ± 0.2 mm | 8.4 ± 0.2 mm | 7.3 ± 0.2 mm | 8.4 ± 0.2 mm | 7.6 ± 0.2 mm | 7.6 ± 0.2 mm | 7.15 ± 0.2 mm |
| Operating voltage | 600 V | 600 V | 600 V | 600 V | 600 V | 600 V | 300/500 V |
| Temperature range | –30 to +105 °C according to UL | –30 to +105 °C according to UL | –30 to +105 °C according to UL | –30 to +105 °C | –30 to +105 °C according to UL | –30 to +105 °C | –30 to +105 °C –40 to +80 °C according to UL |
| Approval | cULus | cULus | cULus | None | cULus | None | cULus |

Cable types with straight plug connection

| Article number | Cable length | Plain cable article number | Voltage selection | |
|----------------|--------------|----------------------------|--|---------------------------------|
| | | | Asynchronous motor 230 or 400 V Synchronous motor | Asynchronous motor 230/400 V |
| 61114712 | 1 m | 1107480 | ● | |
| 61114713 | 3 m | 1107480 | ● | |
| 61114715 | 5 m | 1107480 | ● | |
| 61114716 | 10 m | 1107480 | ● | |
| 61114280 | 1 m | 1107482 | ● | |
| 61114281 | 3 m | 1107482 | ● | |
| 61114282 | 5 m | 1107482 | ● | |
| 61114283 | 10 m | 1107482 | ● | |
| 61114272 | 1 m | 1107481 | | ● |
| 61114273 | 3 m | 1107481 | | ● |
| 61114274 | 5 m | 1107481 | | ● |
| 61114275 | 10 m | 1107481 | | ● |
| 61114255 | 1 m | 1107477 | | ● |
| 61114256 | 3 m | 1107477 | | ● |
| 61114257 | 5 m | 1107477 | | ● |
| 61114258 | 10 m | 1107477 | | ● |
| 61114265 | 1 m | 1107479 | | ● |
| 61114266 | 3 m | 1107479 | | ● |
| 61114267 | 5 m | 1107479 | | ● |
| 61114268 | 10 m | 1107479 | | ● |

Connection diagrams

Abbreviations

| | | | |
|-------|--|----|----------------------|
| ye/gn | = yellow/green | or | = orange |
| bn | = brown | vi | = violet |
| bk | = black | rd | = red |
| gy | = gray | wh | = white |
| bu | = blue | FI | = Frequency inverter |
| TC | = Thermal controller (thermal motor protection switch) | NC | = Not connected |
| BR | = Electromagnetic brakes | | |

Rotation

Note: The rotational direction of the drum motor is shown on the connection diagrams. The rotation indicated is correct when looking at the motor from the connection side.

Cable connections synchronous motor

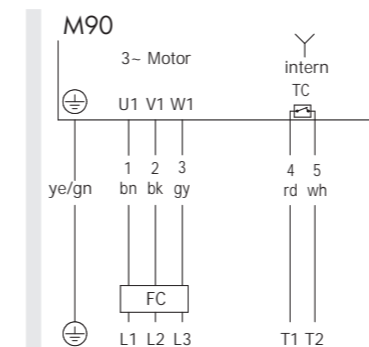

Fig.: 3-phase, 4+2-core cable, winding for 1 voltage, star connection

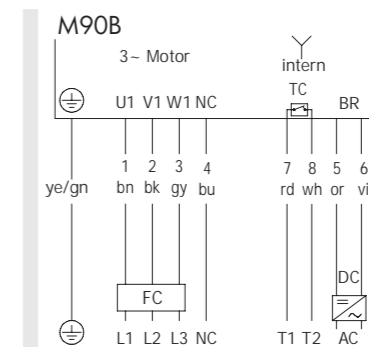

Fig.: 3-phase, 7+2-core cable, winding for 1 voltage, star connection

Terminal box for synchronous motor

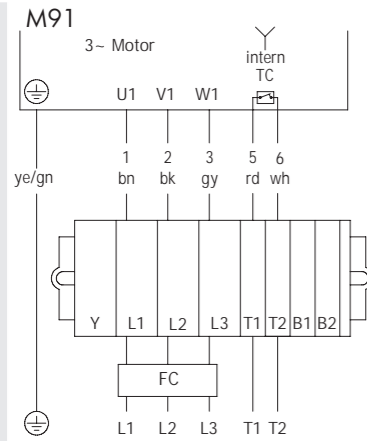

Fig.: 3-phase, 4+2-core cable, winding for 1 voltage, star connection

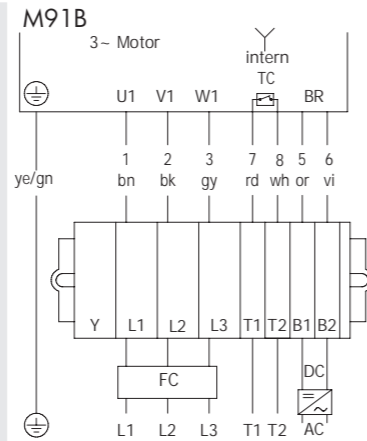

Fig.: With brake, 3-phase, 7+2 core cable, winding for 1 voltage, star connection

Cable connections 3-phase asynchronous motor

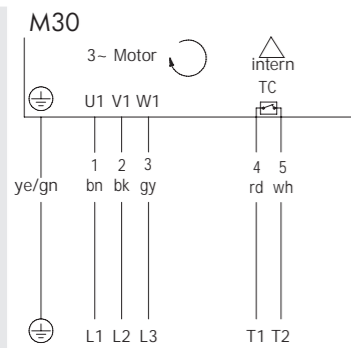

Fig.: 3-phase, 4+2 core cable, winding for 1 voltage, delta connection

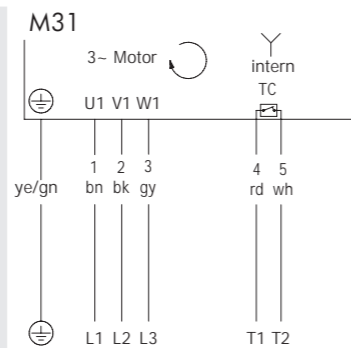

Fig.: 3-phase, 4+2-core cable, winding for 1 voltage, star connection

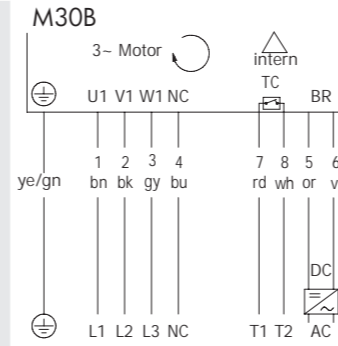

Fig.: With brake, 3-phase, 7+2 core cable, winding for 1 voltage, delta connection

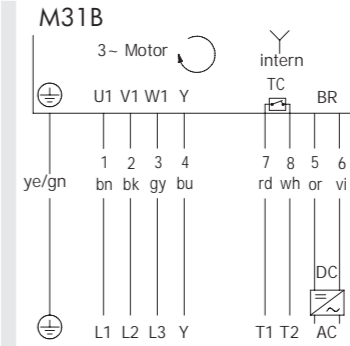

Fig.: With brake, 3-phase, 7+2 core cable, winding for 1 voltage, star connection

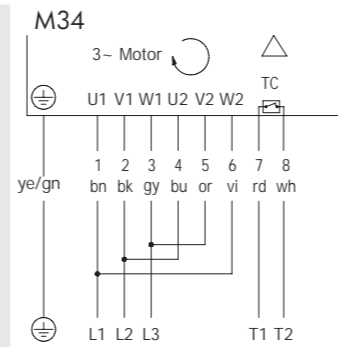

Fig.: 3-phase, 7+2 core cable, winding for 2 voltages, delta connection

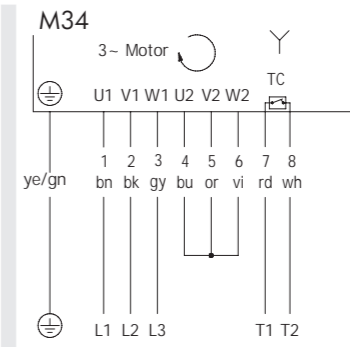

Fig.: 3-phase, 7+2-core cable, winding for 2 voltages, star connection

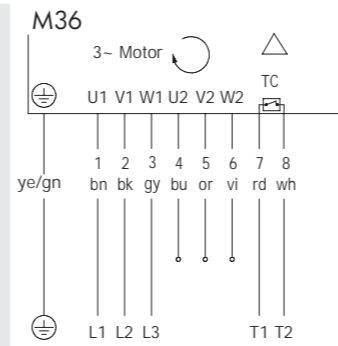

Fig.: 3-phase, 7+2 core cable, 2 speeds, delta connection

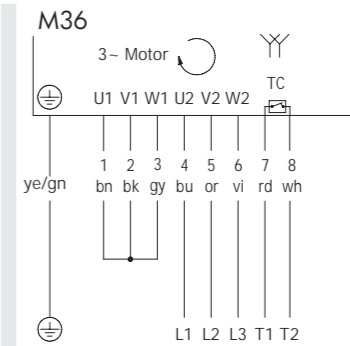

Fig.: 3-phase, 7+2 core cable, 2 speeds, double-star connection

Terminal box 3-phase asynchronous motor

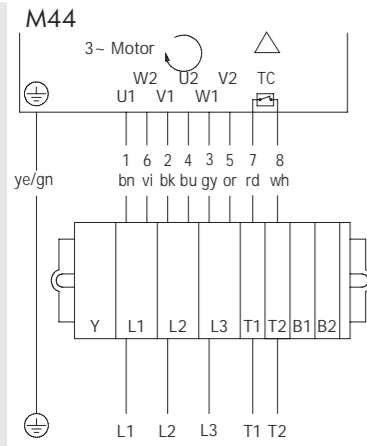

Fig.: 3-phase, winding for 2 voltages, delta connection

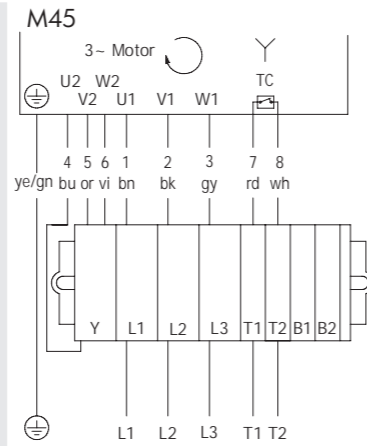

Fig.: 3-phase, winding for 2 voltages, star connection

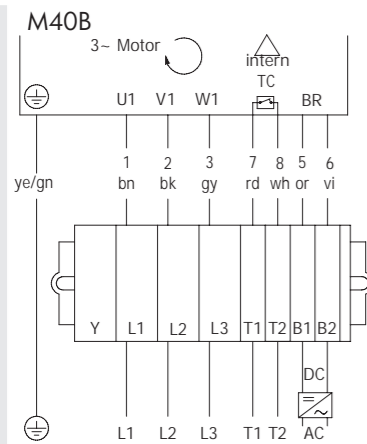

Fig.: With brake, 3-phase, winding for 1 voltage, delta connection

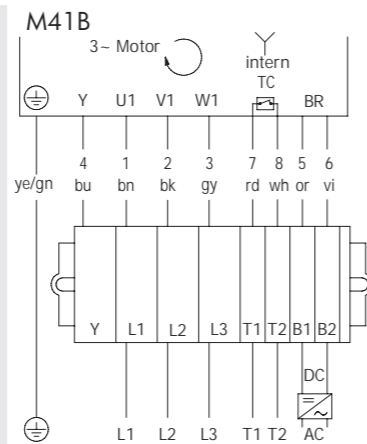

Fig.: With brake, 3-phase, winding for 1 voltage, star connection

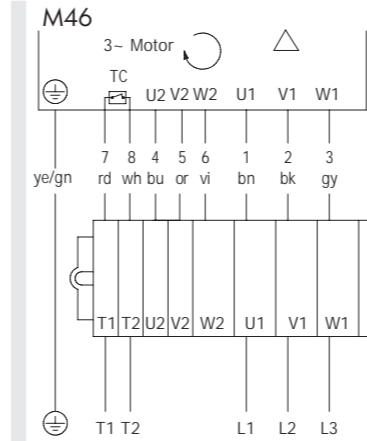

Fig.: 3-phase, 7+2 core cable, 2 speeds, delta connection

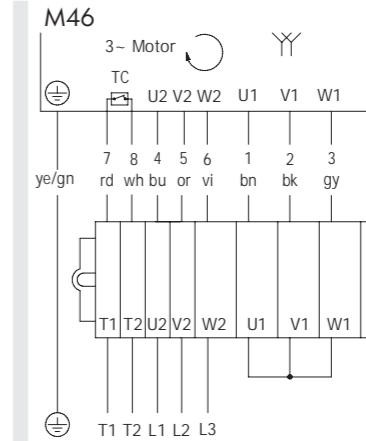

Fig.: 3-phase, 7+2 core cable, 2 speeds, double-star connection

Cable connections 1-phase asynchronous motor

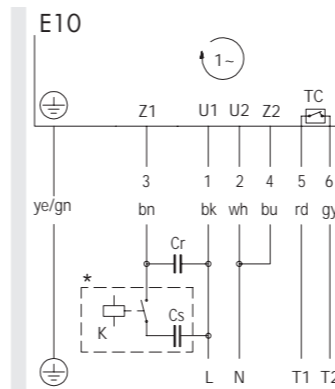

Fig.: 1-phase, 7-core cable

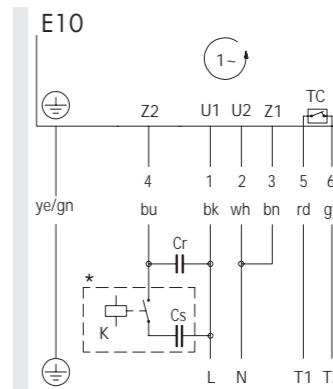

Fig.: 1-phase, 7-core cable

DRUM MOTOR

Connection diagrams

Terminal box 1-phase asynchronous motor

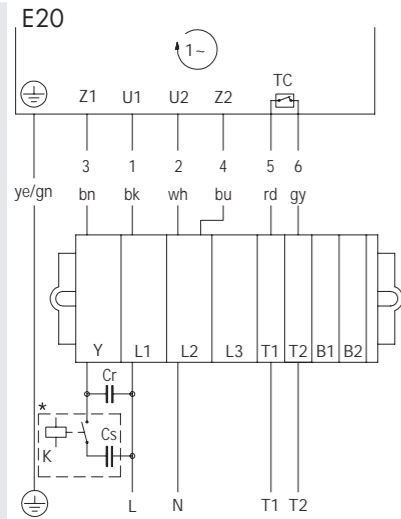

Fig.: 1-phase, 7-core cable

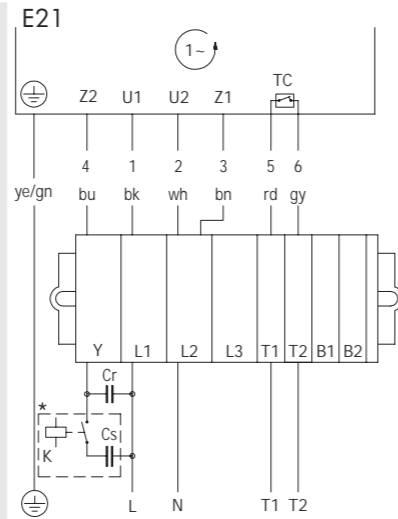

Fig.: 1-phase, 7-core cable

For more information about the starting relay, see page 132.

OPTIONS

Lagging
For friction drive belt applications



Hygienic and loadable

A lagging provides an advantage for drum motors, particularly for wet applications and in food processing, with its typical hygienic requirements. A lagging increases the friction between drum motor and conveyor belt, thereby preventing slippage. On top of that, it is resistant to external influences such as oil, fuels, and other chemicals that may be used for cleaning. Depending on the application, different profiles are available: For high volumes of liquid, a longitudinal grooved lagging redirects moisture between belt and motor, a center V-groove ensures precise belt tracking. Laggings are available in cold and hot vulcanization, whereby the latter meets particularly strict hygiene requirements.

Note: It is important to incorporate a calculation of belt pull and speed that is adjusted to the greater outer diameter of the drum motor.

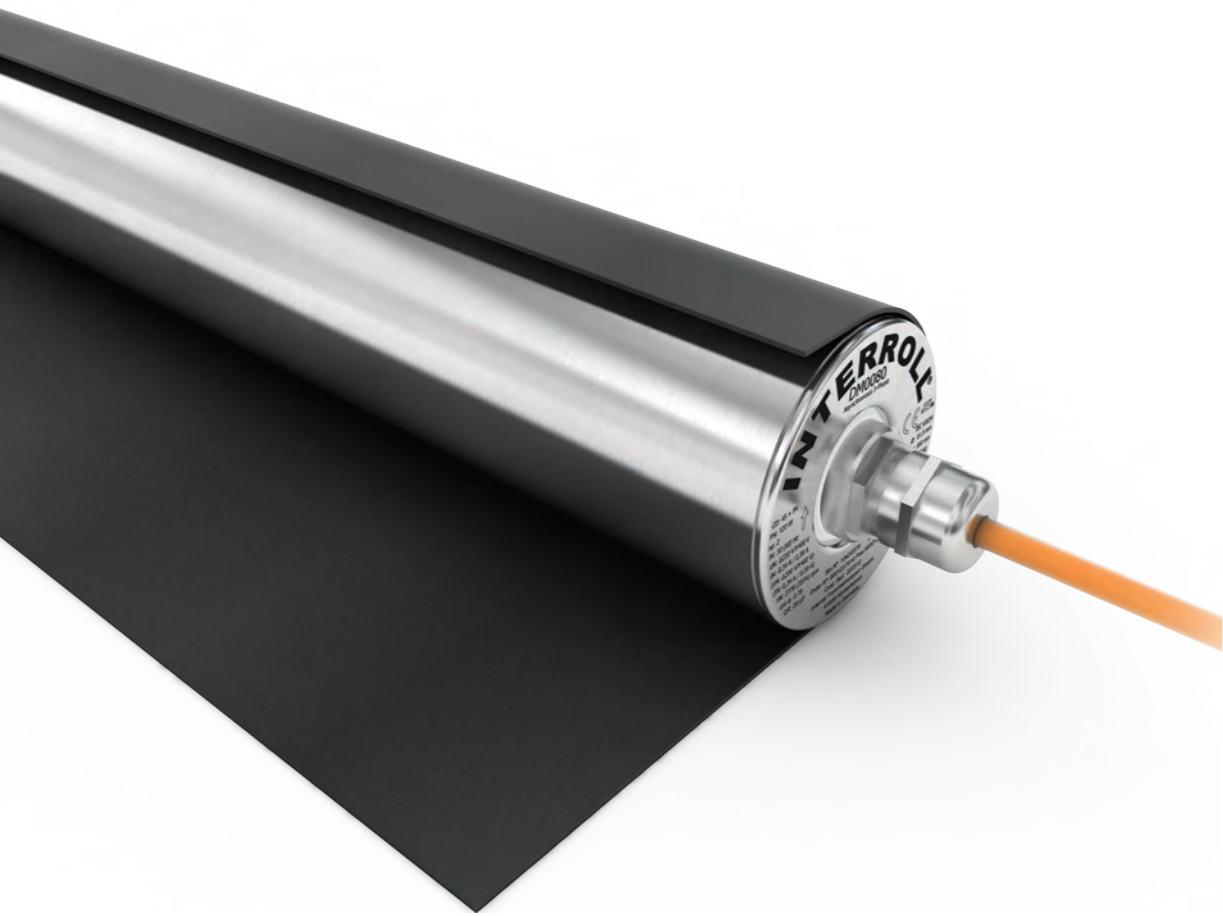

OPTIONS

Lagging
For friction drive belt applications

Technical data

| | |
|--------------------------|--|
| Material | Hot or cold vulcanized NBR Other materials on request |
| Temperature range | -40 to +120 °C |
| Shore hardness | 65 and 70 ± 5 Shore A |

Versions

Cold vulcanization

| Lagging profile | Color | Features | Shore hardness | Thickness [mm] |
|----------------------|-------|---------------------------|----------------|----------------|
| Smooth | Black | Oil- and grease-resistant | 65 ± 5 Shore A | 3; 4 |
| | White | FDA food approved | 70 ± 5 Shore A | |
| Longitudinal grooves | White | FDA food approved | 70 ± 5 Shore A | 8 |
| Diamond patterned | Black | Oil- and grease-resistant | 70 ± 5 Shore A | 8 |

Hot vulcanization

| Lagging profile | Color | Features | Shore hardness | Thickness [mm] |
|----------------------|------------|---|----------------|----------------------------------|
| Smooth | Black | Oil- and grease-resistant | 65 ± 5 Shore A | 2; 3; 4; 5; 6; 8; 10; 12; 14; 16 |
| | White/blue | FDA food approved EC1935/2004 approved | 70 ± 5 Shore A | |
| Longitudinal grooves | Black | Oil- and grease-resistant | 65 ± 5 Shore A | 6; 8; 10; 12; 14; 16 |
| | White/blue | FDA food approved EC1935/2004 approved | 70 ± 5 Shore A | |
| Diamond patterned | Black | Oil- and grease-resistant | 65 ± 5 Shore A | 6; 8; 10; 12; 14; 16 |
| | White/blue | FDA food approved EC1935/2004 approved | 70 ± 5 Shore A | |
| V-groove | Black | Oil- and grease-resistant | 65 ± 5 Shore A | 6; 8; 10; 12; 14; 16 |
| | White/blue | FDA food approved EC1935/2004 approved | 70 ± 5 Shore A | |

OPTIONS

Lagging
For friction drive belt applications

Dimensions

Smooth

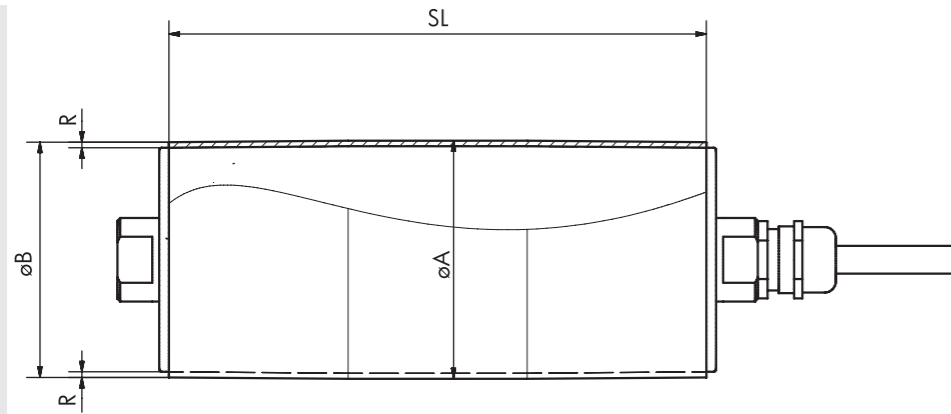

The standard cambers of the lagging are available in the following table.

| Drum motor | Ø Tube [mm] | Cold vulcanization | | | Hot vulcanization | | |
|------------|-------------|--------------------|----------|----------|-------------------|----------|----------|
| | | Min./max. R [mm] | Ø A [mm] | Ø B [mm] | Min./max. R [mm] | Ø A [mm] | Ø B [mm] |
| DM 0080 | 81.5 | 3 | 87.5 | 86.5 | 2 | 85.5 | 84.5 |
| | | 4 | 89.5 | 86.5 | 16 | 113.5 | 112.5 |
| DM 0113 | 113 | 3 | 119 | 118.0 | 2 | 117 | 116.0 |
| | | 4 | 121 | 120.0 | 16 | 145 | 144.0 |

OPTIONS

Lagging
For friction drive belt applications

Longitudinal

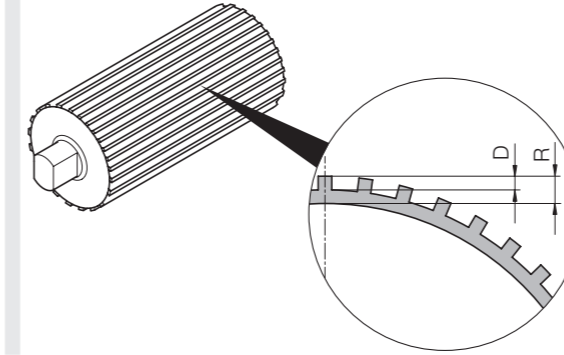

| D [mm] | R, cold vulcanization [mm] | R, hot vulcanization [mm] |
|--------|----------------------------|---------------------------|
| 4 | 8 | 6, 8, 10, 12, 14, 16 |

Diamond patterned

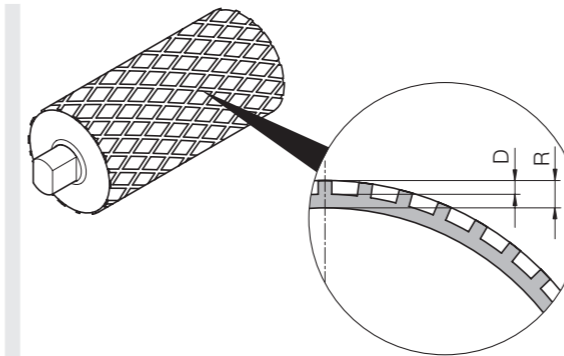

| D [mm] | R, cold vulcanization [mm] | R, hot vulcanization [mm] |
|--------|----------------------------|---------------------------|
| 4 | 8 | 6, 8, 10, 12, 14, 16 |

OPTIONS

Lagging
For friction drive belt applications

V-groove hot vulcanization

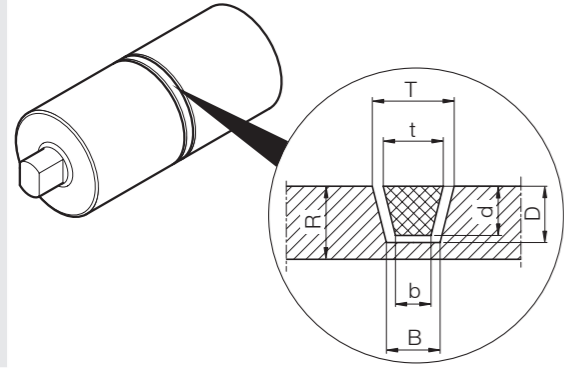

| Groove | R Standard [mm] | R Option [mm] | Groove | | | Belt | | |
|--------|-----------------|---------------|--------|--------|--------|--------|--------|--------|
| | | | T [mm] | B [mm] | D [mm] | t [mm] | b [mm] | d [mm] |
| K6 | 8 | 6 | 10 | 8 | 5 | 6 | 4 | 4 |
| K8 | 8 | 6 | 12 | 8 | 6 | 8 | 5 | 5 |
| K10 | 10 | 8 | 14 | 10 | 7 | 10 | 6 | 6 |
| K13 | 12 | 10 | 17 | 11 | 9 | 13 | 7.5 | 8 |
| K15 | 12 | 10 | 19 | 13 | 9 | 15 | 9.5 | 8 |
| K17 | 14 | 12 | 21 | 13 | 12 | 17 | 9.5 | 11 |

OPTIONS

Lagging
For modular plastic belt applications



Hygienic, quiet and long lifespan

Based on the specifications of the specific belt manufacturer, up to 38 teeth mesh with the profile of the most common modular plastic belts. The lagging made of hot-vulcanized NBR is suitable for applications in food processing with high hygienic requirements: Easy to clean and extremely resistant to oil, grease and chemicals. Furthermore, it ensures smooth running and provides a long lifespan of the belt due to its low abrasion.

Note: It is important to incorporate a calculation of belt pull and speed that is adjusted to the greater outer diameter of the drum motor. Please refer to the velocity factor (VF) in the table page 60.

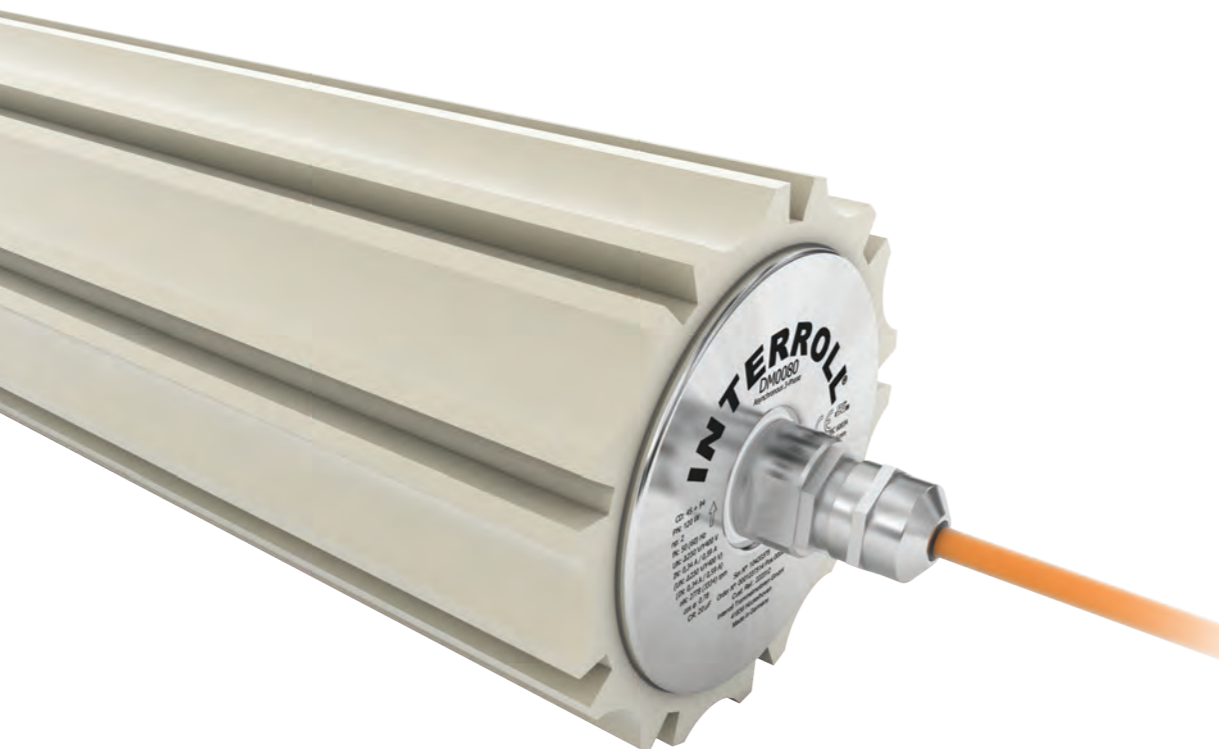

OPTIONS

Lagging
For modular plastic belt applications

Technical data

| | |
|-------------------|--------------------|
| Material | Hot vulcanized NBR |
| Temperature range | -40 to +120 °C |
| Shore hardness | 70 ± 5 Shore A |
| Colors | White/blue |
| Approvals | FDA/EC 1935/2004 |

Versions

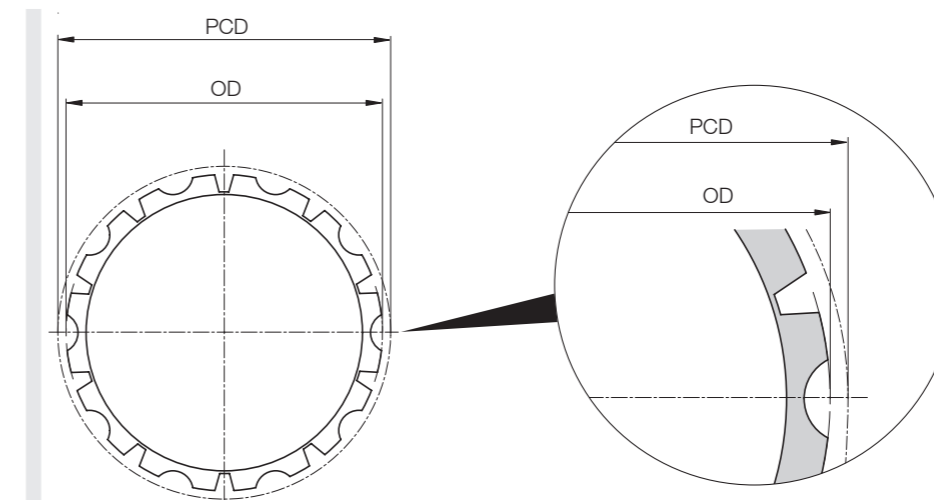

OD = Outer diameter in mm

PCD = Pitch circle diameter in mm

OPTIONS

Lagging
For modular plastic belt applications

| Belt manufacturer | Series | Lagging DM 0080 | | | | Lagging DM 0113 | | | |
|---|----------------|-----------------|---------|----------|------|-----------------|---------|----------|------|
| | | Z | OD [mm] | PCD [mm] | VF | Z | OD [mm] | PCD [mm] | VF |
| Ammeraal Beltech/ Uni-Chains | HDS60500 | 24 | 98.5 | 97.3 | 1.21 | 32 | 131.0 | 129.6 | 1.14 |
| | HDS61000 | 12 | 99.0 | 98.1 | 1.22 | 16 | 132.0 | 130.2 | 1.15 |
| | HDS62000 | 7 | 110.8 | 114.1 | 1.42 | 9 | 144.2 | 146.2 | 1.29 |
| | CNB | 12 | 98.0 | 98.5 | 1.22 | 16 | 131.0 | 130.7 | 1.15 |
| | MPB | 7 | 105.5 | 117.1 | 1.45 | 9 | 140.0 | 148.5 | 1.31 |
| | S-MPB | 12 | 98.1 | 98.1 | 1.21 | 16 | 132.0 | 132.3 | 1.17 |
| Habasit | M1200 PE/AC | 24 | 92.5 | 97.3 | 1.21 | 32 | 125.0 | 129.6 | 1.14 |
| | M1200 PP | 24 | 96.0 | 101.0 | 1.25 | 32 | 128.0 | 132.6 | 1.17 |
| | M2500 | 12 | 99.4 | 99.0 | 1.23 | 16 | 132.8 | 131.6 | 1.16 |
| Intralox | 800 | 7 | 105.5 | 116.5 | 1.45 | 9 | 140.1 | 148.5 | 1.31 |
| | 850 | | | | | 9 | 143.6 | 148.5 | 1.31 |
| | 1600 | 13 | 105.8 | 105.8 | 1.31 | 16 | 130.5 | 130.2 | 1.15 |
| | 1650 | 13 | 104.9 | 105.8 | 1.31 | 16 | 129.3 | 130.2 | 1.15 |
| | 1800 | | | | | 8 | 152.0 | 165.9 | 1.46 |
| | 1100 FG PE/AC | 20 | 91.0 | 98.9 | 1.23 | 26 | 120.6 | 128.4 | 1.13 |
| | 1100 FG PP | 20 | 91.5 | 99.5 | 1.24 | 26 | 121.4 | 129.1 | 1.14 |
| | 1100 FT PE/AC | 20 | 93.5 | 97.3 | 1.21 | 27 | 128.0 | 131.0 | 1.15 |
| | 1100 FT PP | 20 | 94.0 | 98.3 | 1.22 | 26 | 124.0 | 127.6 | 1.12 |
| Rexnord | 1010 | 12 | 97.5 | 98.1 | 1.22 | 16 | 130.0 | 130.2 | 1.15 |
| | 2010 | | | | | 9 | 138.8 | 147.9 | 1.30 |
| Scanbelt | S.25-100 & 600 | 12 | 92.2 | 98.7 | 1.23 | 16 | 123.0 | 128.2 | 1.13 |
| | S.25-800 | 12 | 93.6 | 96.8 | 1.20 | 16 | 125.8 | 128.3 | 1.13 |
| | S.50-100 & 600 | | | | | 9 | 131.2 | 146.8 | 1.29 |
| | S.50-800 | | | | | 9 | 136.0 | 146.2 | 1.29 |
| | S.50-801 | | | | | 9 | 138.0 | 139.0 | 1.22 |
| Forbo-Siegling | LM14 Series 4 | 21 | 93.0 | 95.3 | 1.18 | | | | |
| | LM14 Series 2 | 13 | 107.0 | 107.0 | 1.33 | 16 | 131.5 | 131.5 | 1.16 |
| | LM50 Series 3 | | | | | 9 | 140.0 | 146.2 | 1.29 |
| | LM50 Series 6 | 7 | 107.5 | 116.3 | 1.44 | 9 | 137.5 | 146.2 | 1.29 |

Z = Number of teeth
OD = Outer diameter in mm

PCD = Pitch circle diameter in mm
VF = Velocity factor

If your preferred belt type or manufacturer is not listed here, please contact Interroll.

OPTIONS

Lagging
For positive drive solid homogeneous belts



Hygienic and quiet

The lagging made of Interroll Premium Hygienic PU is suitable for applications in food processing with high hygienic requirements: Easy to clean and extremely resistant to oil, grease and chemicals. Furthermore, it ensures smooth running and provides a long lifespan of the belt due to its low abrasion. This lagging is available for the most common positive drive solid homogeneous belts as well as for motors in applications with positive drive belts.

Note: It is important to incorporate a calculation of belt pull and speed that is adjusted to the greater outer diameter of the drum motor. Please refer to the velocity factor (VF) in the table page 63.

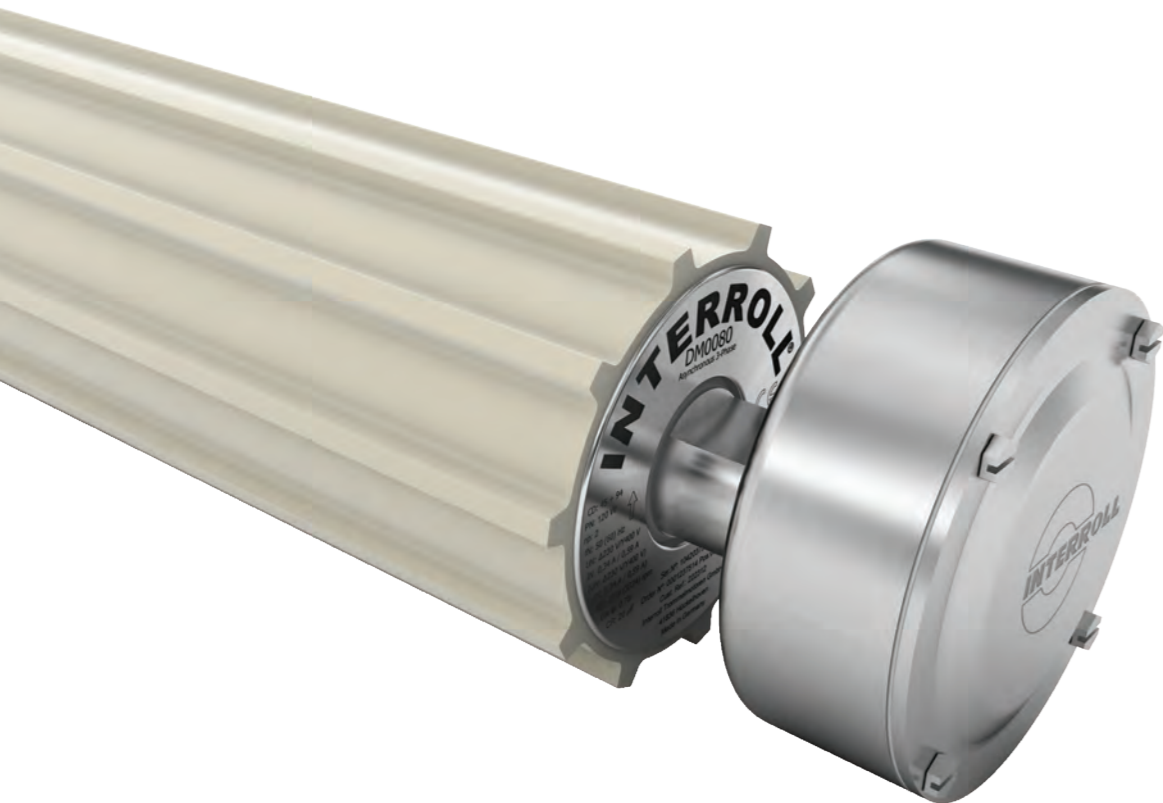

OPTIONS

Lagging
For positive drive solid homogeneous belts

Technical data

| | |
|--------------------------|-------------------------------|
| Material | Interroll Premium Hygienic PU |
| Temperature range | -40 to +80 °C |
| Shore hardness | 82 ± 5 Shore D |

Versions

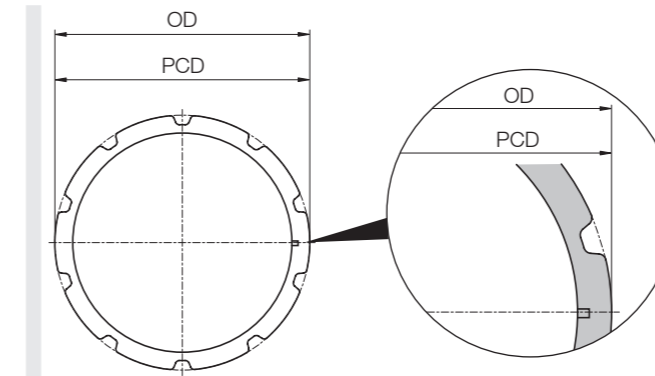

Z = Number of teeth
OD = Outer diameter in mm

PCD = Pitch circle diameter in mm
VF = Velocity factor

| Belt manufacturer | Series | Lagging DM 0080 | | | | Lagging DM 0113 | | | |
|-------------------|-------------------------|-----------------|---------|----------|------|-----------------|---------|----------|------|
| | | Z | OD [mm] | PCD [mm] | VF | Z | OD [mm] | PCD [mm] | VF |
| Intralox | ThermoDrive 8026 | 13 | 104.4 | OD + BT | 1.32 | 18 | 144.3 | OD + BT | 1.32 |
| | ThermoDrive 8050 | | | | | 9 | 142 | 145 | 1.28 |
| Volta | SuperDrive FHB/FHW-3-SD | 9 | 113.4 | OD + BT | 1.43 | 11 | 140 | 143 | 1.26 |

Note: Lace versions cannot be driven with our PU laggings.

If your preferred belt type or manufacturer is not listed here, please contact Interroll.



Precise and wear resistant

Stainless steel sprockets are suitable for driving most common modular plastic belts. They are available for motors in applications with positive drive belts or no belt as well as for drum motors with cylindrical shell and key. The hygienic material is naturally qualified for applications in food processing. The sprockets are cut with the help of lasers and are perfectly fit to size.

Note: It is important to incorporate a calculation of belt pull and speed that is adjusted to the greater outer diameter of the drum motor. Please refer to the velocity factor (VF) in the table page 66. Fixed sprockets are available on request. Only one fixed sprocket per drum motor should be fitted to allow for belt expansion.

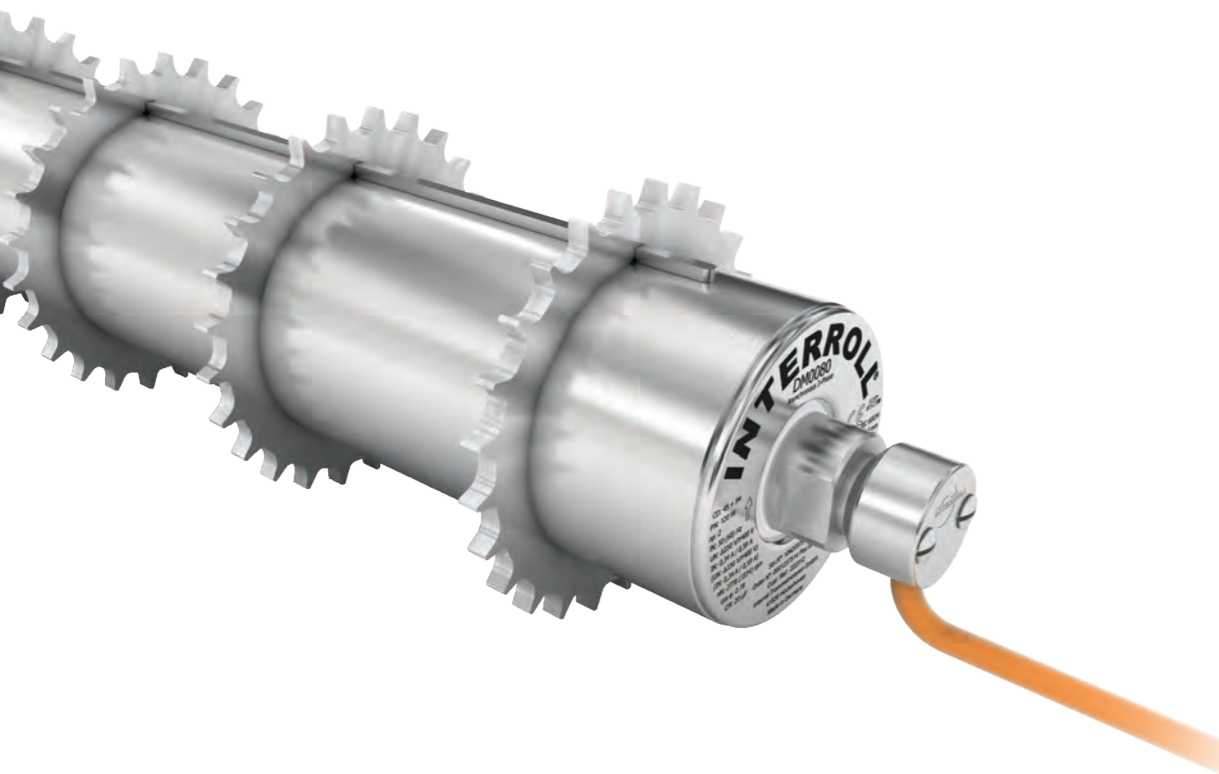

Technical data

| | |
|-----------------|-----------------|
| Material | Stainless steel |
|-----------------|-----------------|

Versions

To use sprockets, drum motors have to be ordered with cylindrical shell and key.

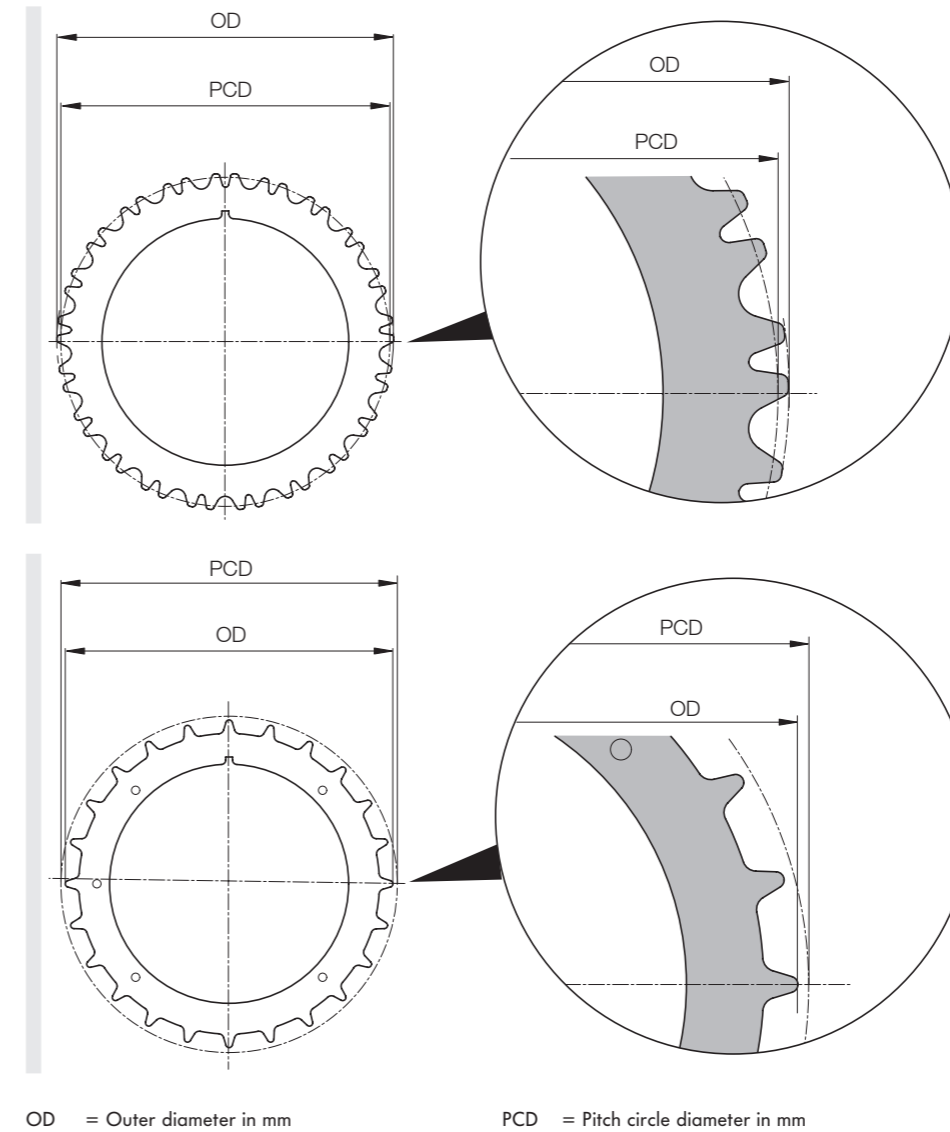

OPTIONS
Sprockets
For modular plastic belt applications

OPTIONS
Sprockets
For modular plastic belt applications

| Belt manufacturer | Series | Rev. | Sprocket DM 0080 | | | | | Sprocket DM 0113 | | | | | |
|-------------------|----------|-------|------------------|---------|----------|-------|--------|------------------|---------|----------|-------|--------|----|
| | | | Z | OD [mm] | PCD [mm] | VF | B [mm] | Z | OD [mm] | PCD [mm] | VF | B [mm] | |
| Intralox | 800 | ● | 8 | 124.2 | 132.0 | 1.64 | 6 | 10 | 158.3 | 164.0 | 1.45 | 6 | |
| | 900 | ● | 12 | 107.0 | 105.0 | 1.30 | 3 | 15 | 135.0 | 131.0 | 1.16 | 3 | |
| | 1000 | ● | 22 | 112.0 | 107.0 | 1.33 | 4 | | | | | | |
| | 1100 | | ● | 24 | 118.5 | 116.0 | 1.44 | 18 | 30 | 147.9 | 145.0 | 1.28 | 18 |
| | | | | 24 | 118.5 | 116.0 | 1.44 | 6 | 30 | 147.9 | 145.0 | 1.28 | 6 |
| | 1400 | ● | | | | | | | | | | | |
| | 1500 | ● | 28 | 118.8 | 113.0 | 1.40 | 6 | 36 | 152.8 | 146.0 | 1.29 | 6 | |
| | 1600 | ● | 14 | 111.8 | 114.0 | 1.42 | 8 | 17 | 135.3 | 138.0 | 1.22 | 8 | |
| | 2000 | ● | | | | | | 16 | 149.3 | 165.0 | 1.46 | 8 | |
| | 2400 | | ● | 14 | 114.2 | 113.8 | 1.41 | 12 | | | | | |
| | | | | 14 | 114.2 | 113.8 | 1.41 | 6 | 19 | 154.6 | 154.0 | 1.36 | 6 |
| | Habasit | M11XX | ● | 26 | 111.9 | 107.1 | 1.33 | 8 | 32 | 136.3 | 131.6 | 1.16 | 6 |
| M12XX | | ● | 25 | 103.7 | 101.0 | 1.25 | 3 | 36 | 150.2 | 149.8 | 1.32 | 3 | |
| M25XX | | ● | 15 | 123.9 | 122.7 | 1.52 | 12 | 20 | 165.1 | 164.0 | 1.45 | 12 | |
| | | | 15 | 123.9 | 122.7 | 1.52 | 12 | 20 | 165.1 | 164.0 | 1.45 | 4 | |
| M50XX | | | | | | | | 10 | 157.2 | 164.0 | 1.45 | 5 | |
| | 10 | | | 157.0 | 164.0 | 1.45 | 6 | | | | | | |
| Rexnord | 880 | ● | | | | | | 25 | 154.20 | 155.0 | 1.37 | 8 | |
| | 1010 | – | 16 | 131.5 | 130.0 | 1.61 | 8 | | | | | | |
| Scanbelt | S.12-400 | ● | 28 | 117.9 | 112.0 | 1.39 | 4 | 36 | 149.8 | 143.9 | 1.27 | 4 | |
| | S.25-100 | – | 14 | 113.1 | 112.0 | 1.39 | 4 | | | | | | |
| | S.25-400 | ● | 13 | 105.0 | 104.0 | 1.29 | 4 | 17 | 139.2 | 136.0 | 1.2 | 4 | |
| | S.50-808 | | | | | | | 10 | 164.0 | 164.0 | 1.45 | 8 | |
| Forbo-Siegling | CM 25 | ● | 13 | 108.1 | 110.0 | 1.37 | 3 | | | | | | |
| | LM 25 | ● | | | | | | 17 | 139.4 | 136.0 | 1.20 | 3 | |

| Belt manufacturer | Series | Rev. | Sprocket DM 0080 | | | | | Sprocket DM 0113 | | | | |
|---------------------------------|---------------|------|------------------|---------|----------|------|--------|------------------|---------|----------|------|--------|
| | | | Z | OD [mm] | PCD [mm] | VF | B [mm] | Z | OD [mm] | PCD [mm] | VF | B [mm] |
| Ammeraal Beltech/ Uni-Chains | SNB | ● | 13 | 107.8 | 106.0 | 1.32 | 3 | 18 | 146.1 | 146.0 | 1.29 | 3 |
| | Flex ONE | | | | | | | 13 | 163.6 | 163.6 | 1.4 | 6 |
| | Light | ● | 17 | 105.0 | 104.0 | 1.29 | 4 | 24 | 147.3 | 146.0 | 1.29 | 4 |
| | Light EP | ● | 9 | 110.6 | 111.0 | 1.38 | 8 | 12 | 147.1 | 147.2 | 1.30 | 8 |
| | M-SNB & M-QNB | ● | 24 | 99.5 | 97.0 | 1.20 | 5 | | | | | |
| | OPB | | | | | | | 10 | 160.1 | 169.0 | 1.5 | 8 |
| | QNB | ● | 15 | 121.50 | 122.0 | 1.52 | 6 | 17 | 137.5 | 138.0 | 1.2 | 6 |
| | SNB M1 | | | | | | | 18 | 148.7 | 146.0 | 1.29 | 3 |
| | SNB M2 | ● | 14 | 119.2 | 114.0 | 1.42 | 3 | 17 | 144.4 | 138.0 | 1.22 | 3 |

Z = Number of teeth
 OD = Outer diameter in mm
 PCD = Pitch diameter in mm
 VF = Velocity factor
 B = Sprocket width in mm
 Rev. = Reversible sprocket

Backstops

Backstops prevent a run-back of the belt and load when the power supply is off. Since such a stop is installed directly at the rotor shaft and operates mechanically, no electrical connection is required: The bearing runs only in one direction. This principle achieves a higher holding torque than does an electromagnetic brake.

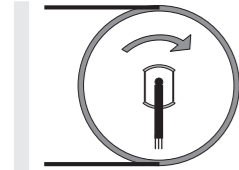

Note: Backstops are available only for asynchronous drum motors.

Rotational direction looking from the connector side: Available for clockwise (standard) or counterclockwise direction.

Balancing

In principle, static or dynamic balancing can be applied - depending on requirement or motor type. The goal in each case is to reduce vibrations and out-of-balance running for sensitive high speed or dynamic weighing applications. Static balancing is applied to the drum motor shell only; therefore the result must be tested for each application. Dynamic balancing, on the other hand, includes the drum motor rotor, shell and end housings, thus meeting a balancing grade of G2.5.

Any external modification, such as fixtures, laggings or sprockets, has an impact on the imbalance.

Technical data for dynamic balancing

| | |
|--------------------------------|--|
| End housing | Stainless steel |
| Rubber lagging material | Only hot vulcanized NBR and PU may be used |
| Max. balancing length | FW ≤ 800 mm |

Electromagnetic brakes

To safely hold loads on reversible inclined and declined conveyors, electromagnetic brakes are used. They operate via rectifiers. The braking force is applied directly to the rotor shaft of the drum motor. When power to the motor is disrupted, the brake will close automatically. Special advantage: Electromagnetic brakes are quiet and operate with low wear.

Note: Electromagnetic brakes are available only for asynchronous drum motors.

Technical data

| Drum motor | Rated torque M [Nm] | Rated power [W] | Rated voltage [V DC] | Rated current [A] | DC switching t1 [ms] | AC switching t1 [ms] | Opening delay time t2 [ms] |
|------------|---------------------|-----------------|----------------------|-------------------|----------------------|----------------------|----------------------------|
| DM 0080 | 0.7 | 12 | 24 | 0.5 | 13 | 80 | 20 |
| | 0.7 | 12 | 104 | 0.12 | 13 | 80 | 20 |
| DM 0113 | 1.5 | 24 | 24 | 1.0 | 26 | 200 | 30 |
| | 1.5 | 24 | 104 | 0.23 | 26 | 200 | 30 |
| | 1.5 | 24 | 207 | 0.12 | 26 | 200 | 30 |

Response time

The brake opening and closing response time can vary substantially depending on the following:

- Oil type and viscosity
- Oil quantity in the drum motor
- Ambient temperature
- Internal operating temperature of the motor
- Switching at input (AC switching) or at output (DC switching)

The difference between AC switching and DC switching is shown in the following table:

| | AC switching | DC switching |
|------------------------------|--------------|---------------|
| Closing response time | Slow | Fast |
| Brake voltage | approx. 1 V | approx. 500 V |

Note: For DC switching, the switching contacts must be protected against damage from high voltage.

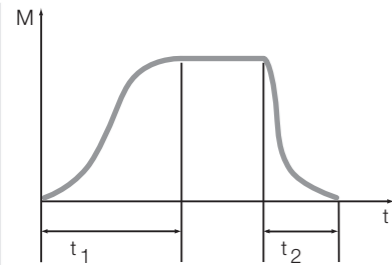

Fig.: Closing and opening response time

t_1 = Closing response time
 t_2 = Opening response time

Reduction of braking torque

The rated braking torque is heavily influenced by the operating conditions inside the drum motor (operation in oil at high temperatures) and the ambient temperature. To calculate the holding torque limit on the drum shell, you need to multiply the rated torque of the brake by the gear ratio of the drum motor. For safety reasons, the calculated brake torque has to be at least 25 % higher than the needed load torque.

Rectifiers

Electromagnetic brakes on drum motors are operated via rectifiers. Different versions are available depending on the applications: Half-wave and bridge rectifiers for standard applications as well as fast acting and multiswitch rectifiers for applications in which short opening delay times are necessary.

Note: Rectifiers, just like electromagnetic brakes, are available only for asynchronous drum motors.

Every rectifier is an external component that must be covered or installed in a control box as close to the brake as possible.

Technical data

| Input voltage [V AC] | Brake voltage [V DC] | Starting voltage [V DC] | Holding voltage [V DC] | Version | Application | Article number |
|----------------------|----------------------|-------------------------|------------------------|----------------------------|-------------|----------------|
| 115 | 104 | 104 | 52 | Fast-acting rectifier | A or B | 61 011 343 |
| 230 | 207 | 207 | 104 | Fast-acting rectifier | A or B | 61 011 343 |
| 230 | 104 | 104 | 104 | Half wave/bridge rectifier | A or B | 1 001 440 |
| 230 | 104 | 190 | 52 | Phase rectifier | A | 1 001 442 |
| 400 | 104 | 180 | 104 | Multiswitch rectifier | A | 1 003 326 |
| 460 | 104 | 180 | 104 | Multiswitch rectifier | A | 1 003 326 |
| 460 | 207 | 207 | 207 | Half wave/bridge rectifier | A or B | 1 001 441 |

A = Continuous operation
B = Frequent starts/stops

Using a fast acting rectifier or a phase rectifier will save energy because the holding voltage is lower than the starting voltage.

Shielded cables should be used to protect against EMC.

Dimensions

Half wave/bridge rectifier

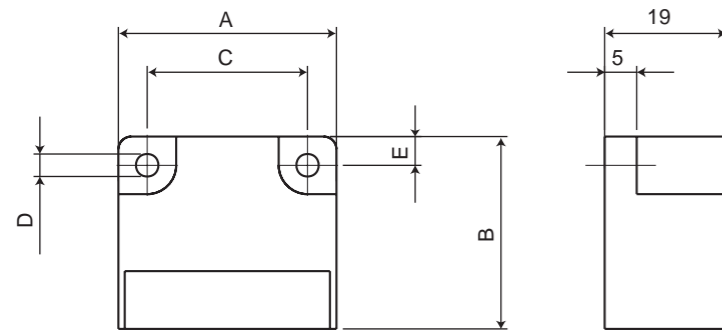

| Article number | A [mm] | B [mm] | C [mm] | D [mm] | E [mm] |
|----------------|--------|--------|--------|--------|--------|
| 1001440 | 34 | 30 | 25 | 3.5 | 4.5 |
| 1001441 | 64 | 30 | 54 | 4.5 | 5 |

Phase rectifier

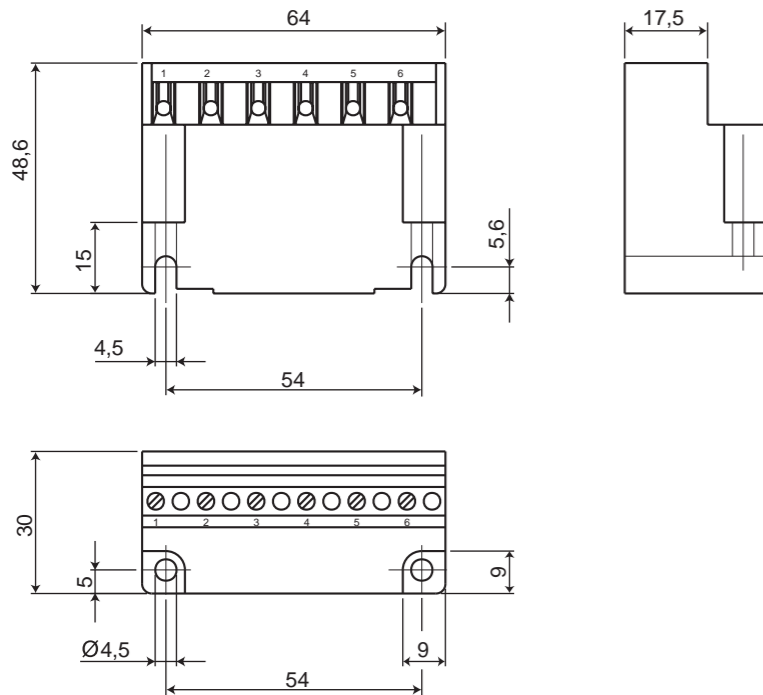

Fast-acting rectifier

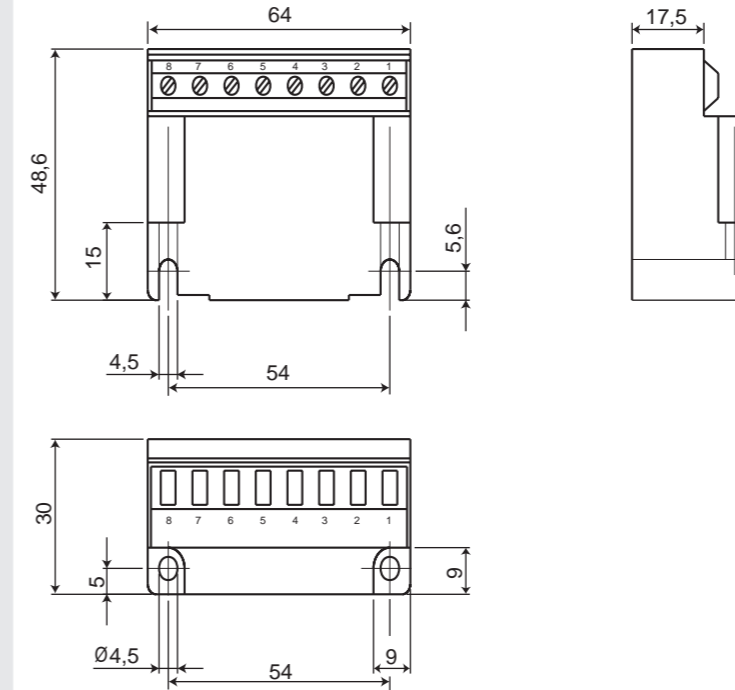

Multiswitch rectifier

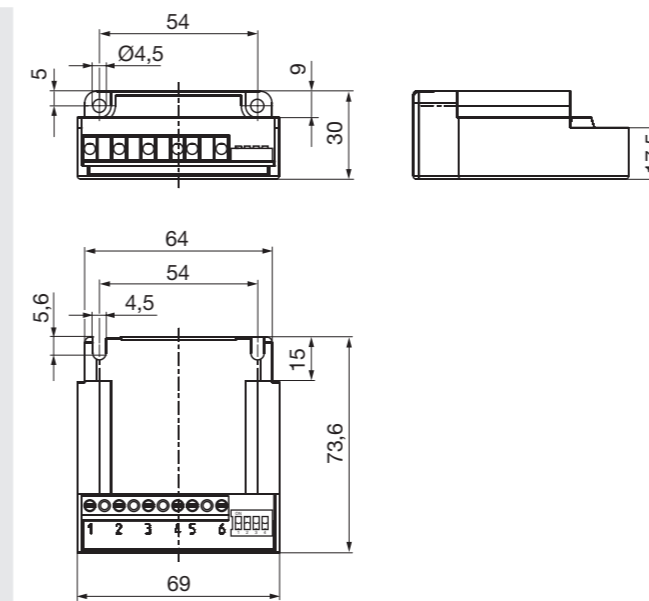

Connection diagram

Interroll recommends installing a switch between (3) and (4) for fast brake release.

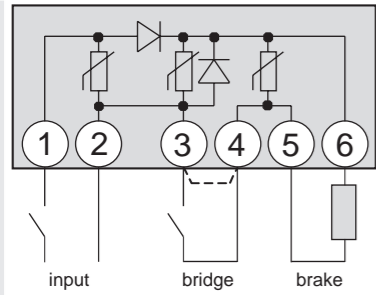

Fig.: Half-wave rectifier

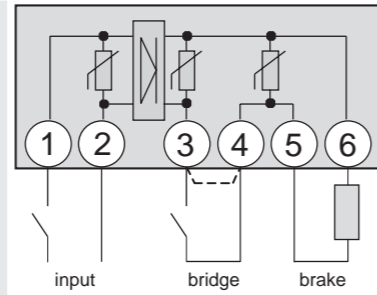

Fig.: Bridge rectifier

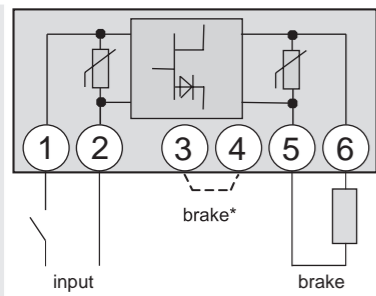

Fig.: Phase rectifier

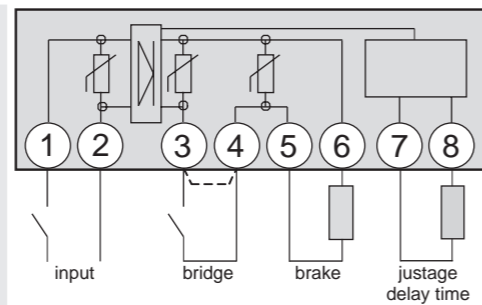

Fig.: Fast-acting rectifier

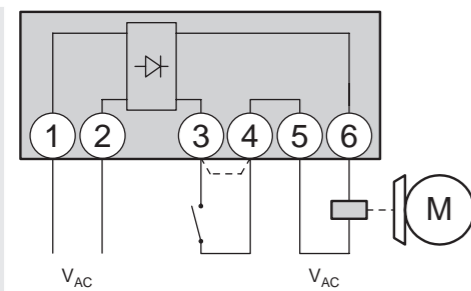

Fig.: Multiswitch rectifier

Feedback devices

If speed, direction and position of the belt or load are to be permanently monitored and controlled, the use of an encoder is recommended. It enables a system control with closed control loop by transmitting low- to high-resolution signals to an external control unit. An encoder is installed onto the rotor shaft or embedded in the rotor bearing and cannot be used simultaneously with a brake or a backstop. Incremental and absolute value encoders are available as encoder types.

All resolutions and speeds provided in the following table refer to the rotor shaft. The drum motor gear ratio must be considered to find the values related to the drum shell.

| Encoder types | | Asynchronous drum motors | Synchronous drum motors |
|----------------------------|-------------------|--------------------------|-------------------------|
| SKF 32 incremental encoder | 32 pulses | ● | |
| RLS incremental encoder | 64 to 1024 pulses | ● | ● |
| LTN resolver | 2-pole resolver | ● | ● |

Technical data

SKF 32 incremental encoder

| | |
|-----------------------|-----------------------------|
| Power supply | $V_{dd} = 5 - 24 \text{ V}$ |
| Current consumption | Max. 20 mA |
| Electrical interface | Open collector NPN |
| Output increments | A, B |
| Increments resolution | 32 pulses/revolution |
| Max. cable length | 10 m |

Note: Interroll recommends the use of an optocoupler for the following reasons:

- To protect the encoder
- To enable connection to other levels such as PNP
- To get the maximum potential between high and low signal

RLS incremental encoder

| | |
|------------------------------|---|
| Power supply | $V_{dd} = 5\text{ V} \pm 5\%$ |
| Current consumption | 35 mA |
| Electrical interface | RS422 |
| Output increments | A, B, Z, /A, /B, /Z |
| Increments resolution | 64; 512; 1024 pulses/revolution 2048 pulses/revolution (max. rotor speed 2500 1/min) |
| Max. cable length | 5 m |

LTN resolver

| | |
|------------------------------|----------------|
| Power supply | 7 V |
| Input frequency range | 5 kHz/10 kHz |
| Input current | 58 mA/36 mA |
| Number of poles | 2 |
| Transformation ratio | $0.5 \pm 10\%$ |
| Max. cable length | 10 m |

Connection diagrams

Abbreviations

| | | | |
|-------|----------------|----|----------------------------|
| ye/gn | = yellow/green | pk | = pink |
| wh | = white | rd | = red |
| bn | = brown | bu | = blue |
| gn | = green | TC | = Thermal controller (WSK) |
| ye | = yellow | BR | = Electromagnetic brakes |
| () | = other color | NC | = Not connected |
| gy | = gray | | |

SKF 32 incremental encoder

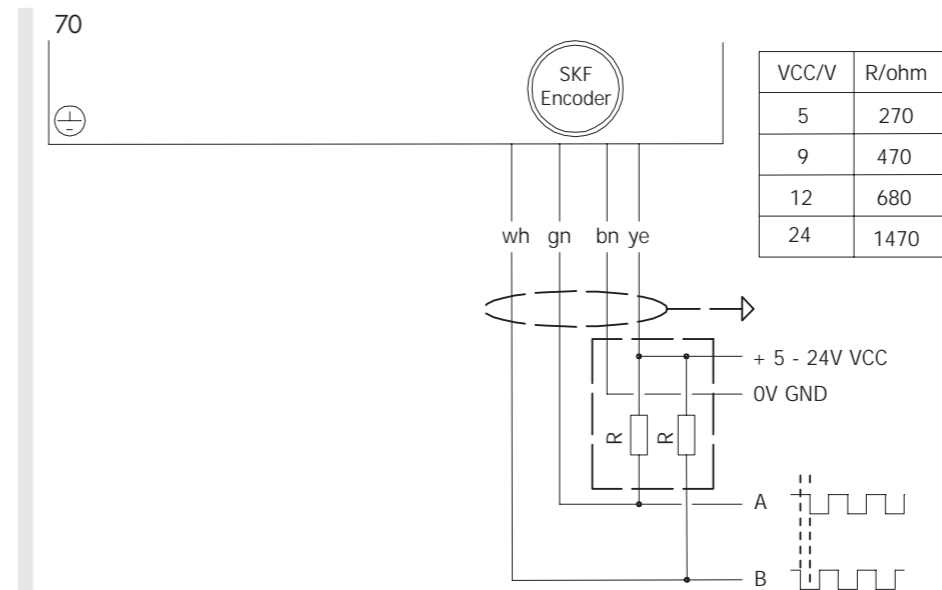

RLS incremental encoder

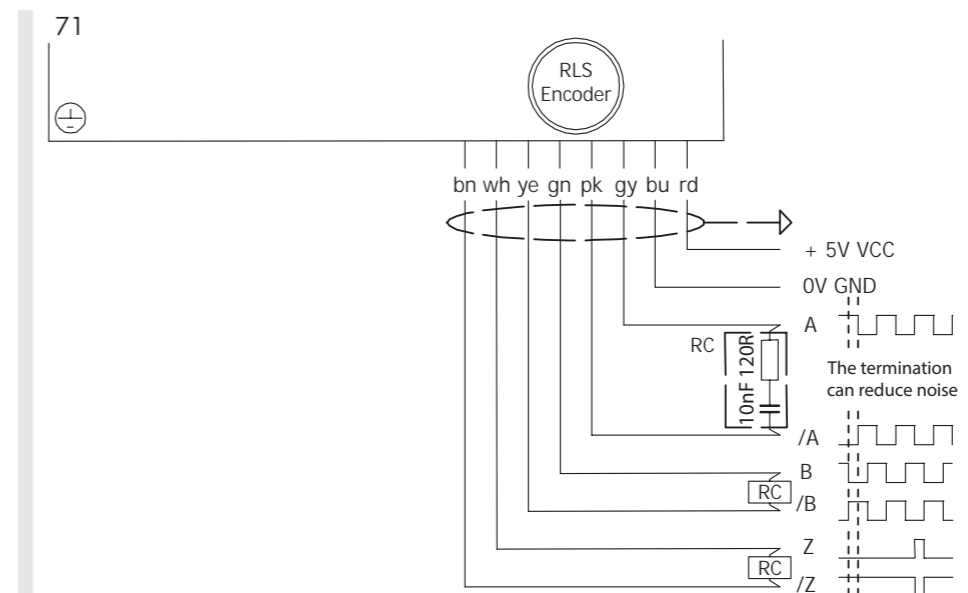

LTN resolver

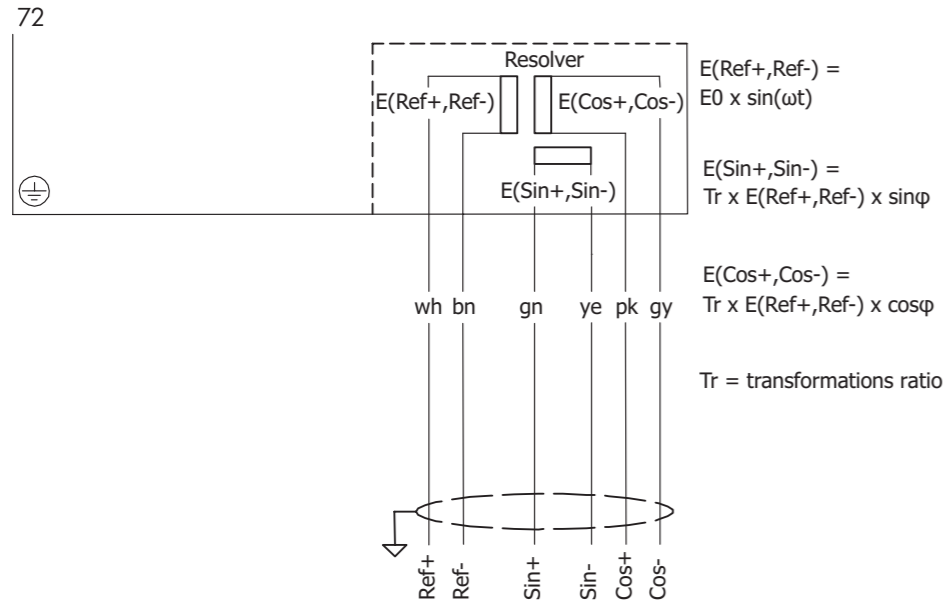

Cable

| | Cable for incremental encoder SKF 32 | Cable for incremental encoder RLS | Cable for resolver LTN |
|------------------------------------|---|--------------------------------------|-------------------------------|
| Main cores (number) | 4 | 8 | 6 |
| Cross section | 0.14 mm ² | 0.14 mm ² | 0.14 mm ² |
| Numeric code and color code | Color code | Color code | Color code |
| Insulation conductors (main cores) | PVC | PVC | PVC |
| Insulation conductors (data cores) | PVC | PVC | PVC |
| Halogen-free | No | Yes | No |
| Color of outer sheath | Gray | Gray | Gray |
| Shielded | Copper | Copper | Copper |
| Outside diameter | 4.3 ± 0.3 mm | 5.0 ± 0.2 mm | 5.8 ± 0.3 mm |
| Operating voltage max. | 250 V | 524 V | 350 V |
| Temperature range | -20 to +105 °C according to UL | -20 to +105 °C according to UL | -20 to +80 °C according to UL |

ACCESSORIES

Mounting brackets
For drum motors and idler pulleys

Mounting brackets

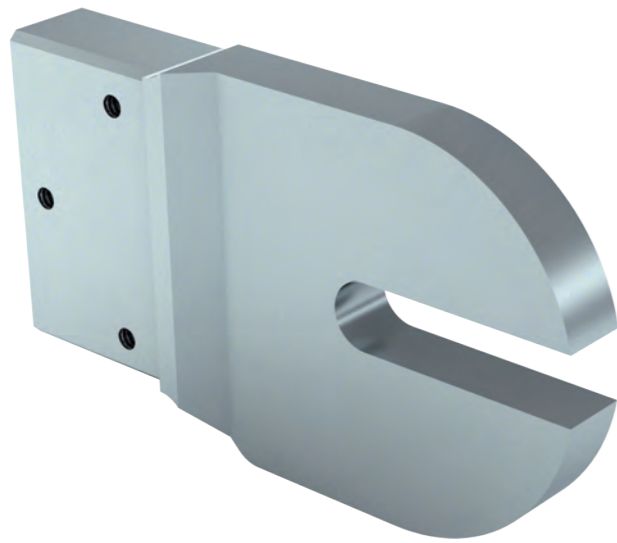

In order to securely fasten Interroll Drum Motors, the corresponding idler pulleys or motors with cable connectors or terminal boxes, suitable brackets made of stainless steel, aluminum and PE are available. It is important that the drum motors feature a continuous threaded hole in the front shaft and idler pulleys a corresponding drilled hole in both shaft ends.

For the dimensions of shafts with threaded holes, refer to the dimensional drawings for the corresponding drum motor.

ACCESSORIES

Mounting brackets
For drum motors and idler pulleys

Product selection

| Drum motor | Idler pulley | Bracket set | Material | Electrical connector | Article number | | |
|------------|--------------|-------------|----------|---|----------------|-----------|-----------|
| | | | | | WAF 13.5 mm | WAF 20 mm | WAF 25 mm |
| DM 0080 | | A + B | Aluminum | Elbow connector Straight connector Terminal box | 61008694 | 61113879 | 61113880 |
| | DM 0080 | B + C | Aluminum | | 61008696 | 61113885 | 61113886 |
| DM 0080 | | A + B | PE | Elbow connector Straight connector Terminal box | 61008693 | 61113889 | 61113890 |
| | DM 0080 | B + C | PE | | 61008695 | 61113895 | 61113896 |
| DM 0080 | | A + B | VA | Elbow connector Straight connector Terminal box | 61113943 | 61113944 | 61113945 |
| | DM 0080 | B + C | VA | | 61113946 | 61113947 | 61113948 |
| DM 0113 | | A + B | Aluminum | Elbow connector Straight connector Terminal box | | 61008699 | 61115658 |
| | DM 0113 | B + C | Aluminum | | | 61008701 | 61115664 |
| DM 0113 | | A + B | PE | Elbow connector Straight connector Terminal box | | 61006805 | 61115659 |
| | DM 0113 | B + C | PE | | | 61008697 | 61115662 |
| DM 0113 | | A + B | VA | Elbow connector Straight connector Terminal box | | 61115655 | 61115657 |
| | DM 0113 | B + C | VA | | | 61115654 | 61115663 |
| DM 0113 | | A + B | VA | Cable connection slot | | 61115656 | 61115660 |
| | DM 0113 | B + C | VA | | | 61115654 | 61115663 |

WAF = Width across flats

ACCESSORIES

Mounting brackets
For drum motors and idler pulleys

Mounting overview

Brackets must be mounted in the following way:

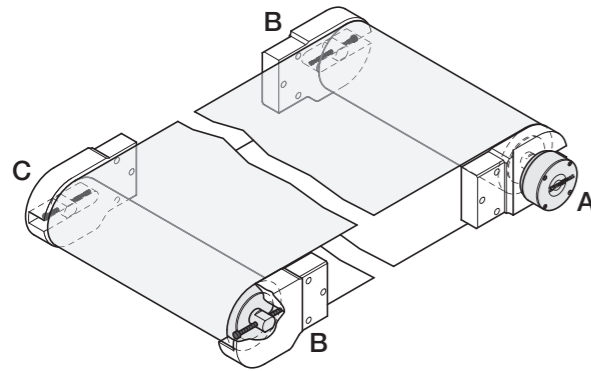

Dimensions DM 0080

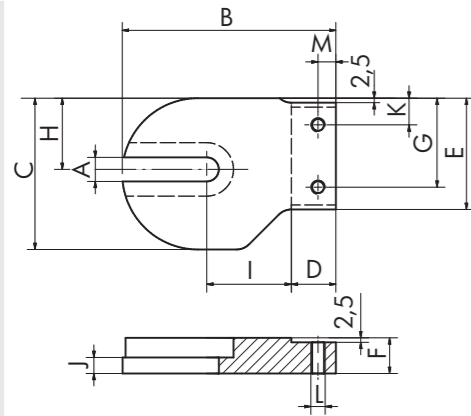

Fig.: Right bracket (A) aluminum or VA

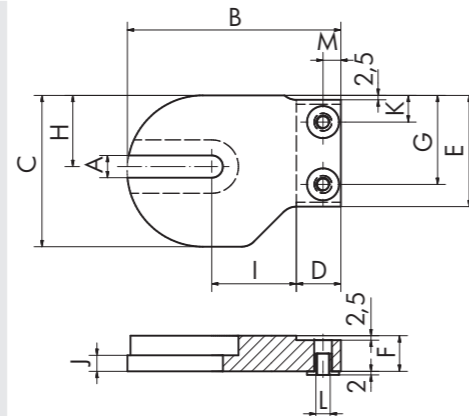

Fig.: Right bracket (A) PE

| Drum motor/deflection roller | A [mm] | B [mm] | C [mm] | D [mm] | E [mm] | F [mm] | G [mm] | H [mm] | I [mm] | J [mm] | K [mm] | L | M [mm] |
|------------------------------|-----------|-----------|-----------|-----------|-----------|-----------|-----------|-----------|-----------|-----------|-----------|----|-----------|
| DM 0080 | 13.5 | 120 | 85 | 25 | 62.5 | 20 | 50 | 40 | 47.5 | 9 | 15 | M8 | 10 |
| | 20 | 120 | 85 | 25 | 62.5 | 20 | 50 | 40 | 47.5 | 9 | 15 | M8 | 10 |
| | 25 | 120 | 85 | 25 | 62.5 | 20 | 50 | 40 | 47.5 | 9 | 15 | M8 | 10 |

ACCESSORIES

Mounting brackets
For drum motors and idler pulleys

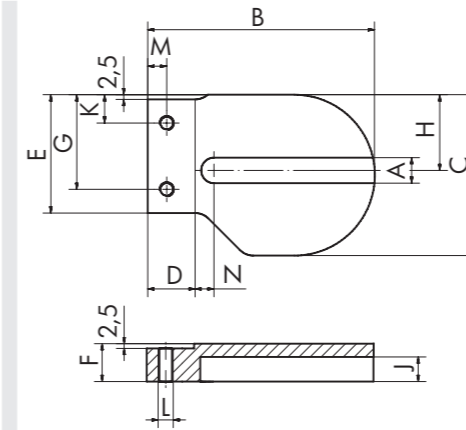

Fig.: Left bracket (B) aluminum or VA

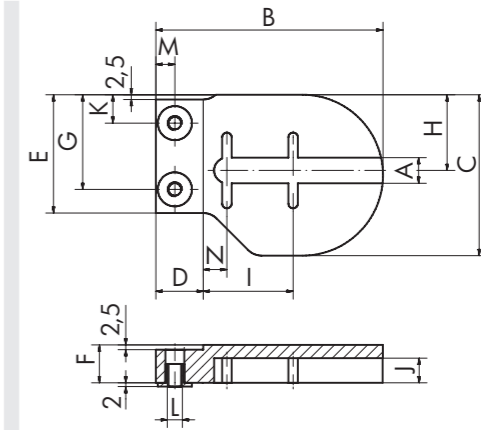

Fig.: Left bracket (B) PE

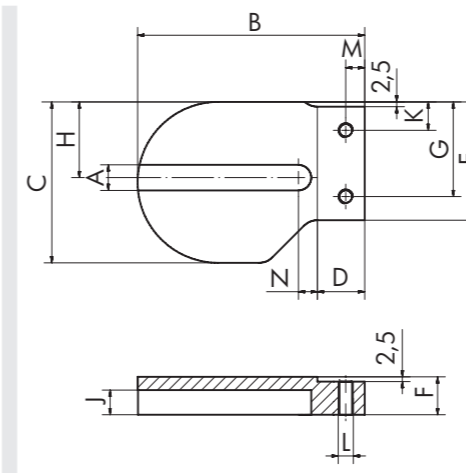

Fig.: Right bracket (C) aluminum or VA

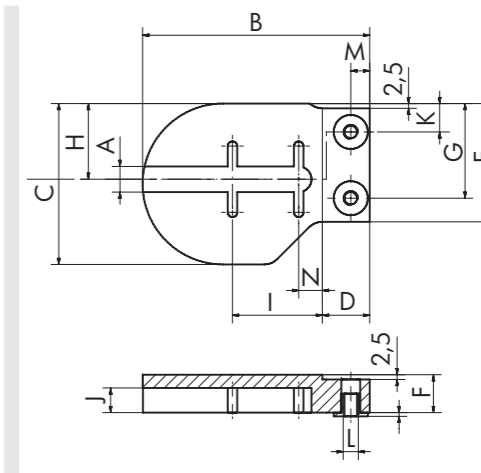

Fig.: Right bracket (C) PE

ACCESSORIES

Mounting brackets
For drum motors and idler pulleys

| Drum motor/idler pulley | Material | A [mm] | B [mm] | C [mm] | D [mm] | E [mm] | F [mm] | G [mm] | H [mm] | I [mm] | J [mm] | K [mm] | L [mm] | M [mm] | N [mm] |
|-------------------------|----------|--------|--------|--------|--------|--------|--------|--------|--------|--------|--------|--------|--------|--------|--------|
| DM 0080 | Aluminum | 13.5 | 120 | 85 | 25 | 62.5 | 20 | 50 | 40 | - | 13 | 15 | M8 | 10 | 10 |
| | | 20 | 120 | 85 | 25 | 62.5 | 20 | 50 | 40 | - | 13 | 15 | M8 | 10 | 10 |
| | | 25 | 120 | 85 | 25 | 62.5 | 20 | 50 | 40 | - | 13 | 15 | M8 | 10 | 10 |
| | PE | 13.5 | 120 | 85 | 25 | 62.5 | 20 | 50 | 40 | 42.5 | 13 | 15 | M8 | 10 | 12.5 |
| | | 20 | 120 | 85 | 25 | 62.5 | 20 | 50 | 40 | 42.5 | 13 | 15 | M8 | 10 | 12.5 |
| | | 25 | 120 | 85 | 25 | 62.5 | 20 | 50 | 40 | 42.5 | 13 | 15 | M8 | 10 | 12.5 |
| | VA | 13.5 | 120 | 85 | 25 | 62.5 | 20 | 50 | 40 | - | 13 | 15 | M8 | 10 | 10 |
| | | 20 | 120 | 85 | 25 | 62.5 | 20 | 50 | 40 | - | 13 | 15 | M8 | 10 | 10 |
| | | 25 | 120 | 85 | 25 | 62.5 | 20 | 50 | 40 | - | 13 | 15 | M8 | 10 | 10 |

Dimensions DM 0113

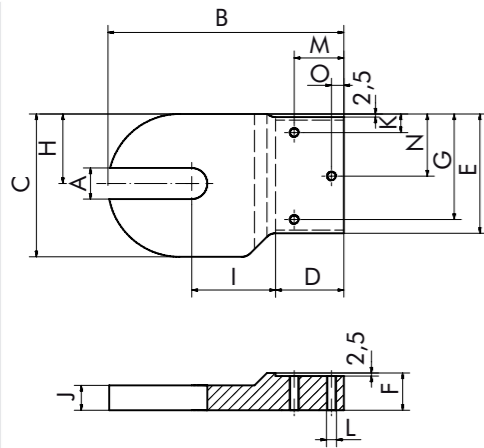

Fig.: Right bracket (A) aluminum or VA

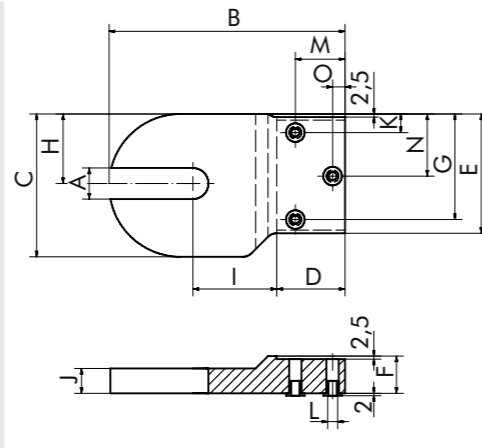

Fig.: Right bracket (A) PE

| Drum motor/deflection roller | A [mm] | B [mm] | C [mm] | D [mm] | E [mm] | F [mm] | G [mm] | H [mm] | I [mm] | J [mm] | K [mm] | L [mm] | M [mm] | N [mm] | O [mm] |
|------------------------------|--------|--------|--------|--------|--------|--------|--------|--------|--------|--------|--------|--------|--------|--------|--------|
| DM 0113 | 20 | 190 | 115 | 55 | 96 | 30 | 85 | 56 | 67.5 | 20 | 15 | M8 | 40 | 50 | 10 |
| | 25 | 190 | 115 | 55 | 96 | 30 | 85 | 56 | 67.5 | 20 | 15 | M8 | 10 | 50 | 10 |

ACCESSORIES

Mounting brackets
For drum motors and idler pulleys

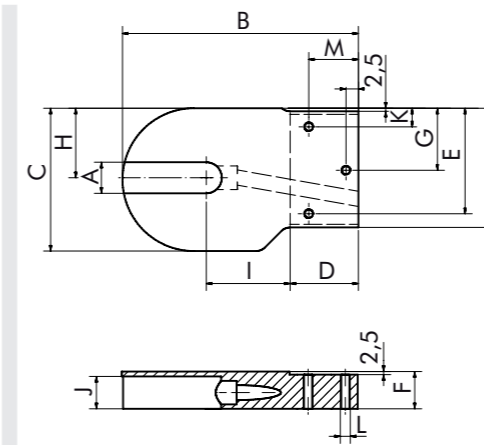

Fig.: Right bracket (A) aluminum or VA with cable connection slot

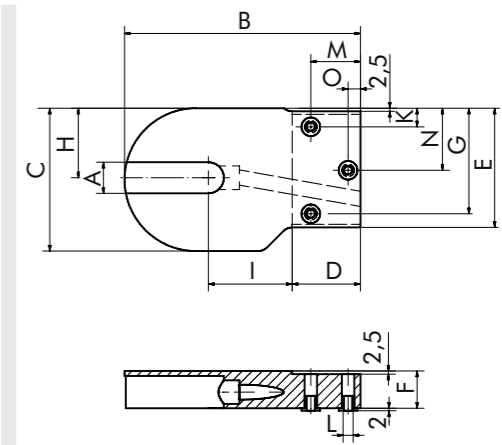

Fig.: Right bracket (A) PE for drum motor with cable connection slot

| Drum motor/deflection roller | A [mm] | B [mm] | C [mm] | D [mm] | E [mm] | F [mm] | G [mm] | H [mm] | I [mm] | J [mm] | K [mm] | L [mm] | M [mm] | N [mm] | O [mm] |
|------------------------------|--------|--------|--------|--------|--------|--------|--------|--------|--------|--------|--------|--------|--------|--------|--------|
| DM 0113 | 20 | 190 | 115 | 55 | 96 | 30 | 85 | 56 | 67.5 | 26 | 15 | M8 | 40 | 50 | 10 |
| | 25 | 190 | 115 | 55 | 96 | 30 | 85 | 56 | 67.5 | 26 | 15 | M8 | 10 | 50 | 10 |

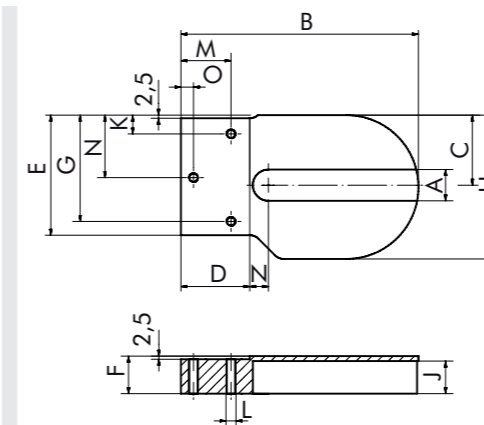

Fig.: Left bracket (B) aluminum or PE

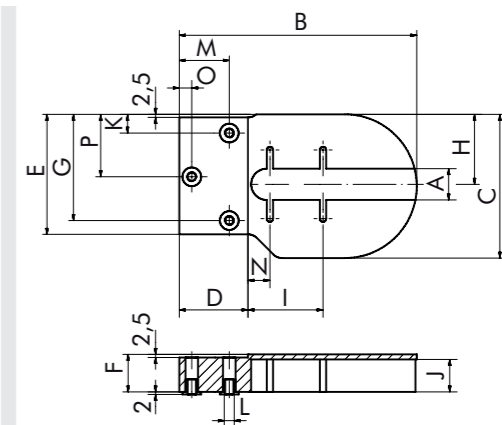

Fig.: Left bracket (B) PE

ACCESSORIES

Mounting brackets
For drum motors and idler pulleys

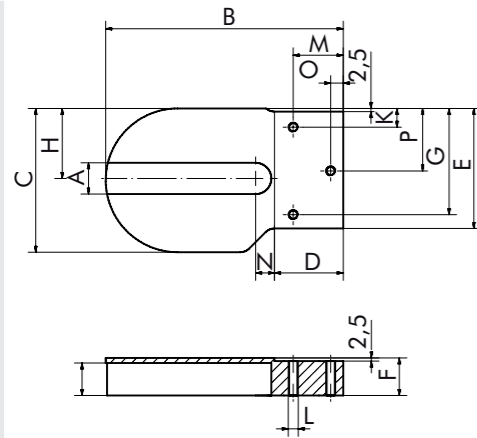

Fig.: Right bracket (C) aluminum or PE

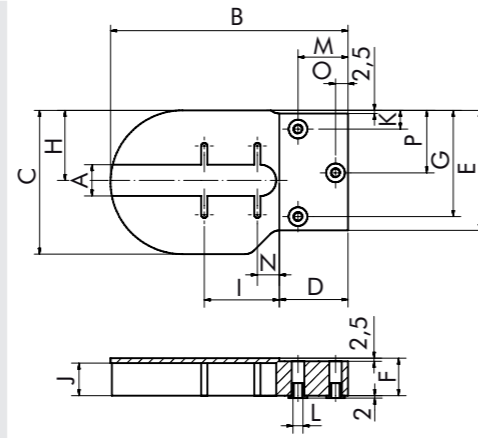

Fig.: Right bracket (C) PE

| Drum motor/idler pulley | Material | A [mm] | B [mm] | C [mm] | D [mm] | E [mm] | F [mm] | G [mm] | H [mm] | I [mm] | J [mm] | K [mm] | L [mm] | M [mm] | N [mm] | O [mm] | P [mm] |
|-------------------------|----------|--------|--------|--------|--------|--------|--------|--------|--------|--------|--------|--------|--------|--------|--------|--------|--------|
| DM 0113 | Aluminum | 20 | 190 | 115 | 55 | 96 | 30 | 85 | 56 | - | 26 | 15 | M8 | 40 | 15 | 10 | 50 |
| | | 25 | 190 | 115 | 55 | 96 | 30 | 85 | 56 | - | 26 | 15 | M8 | 40 | 15 | 10 | 50 |
| | PE | 20 | 190 | 115 | 55 | 96 | 30 | 85 | 56 | 60 | 26 | 15 | M8 | 40 | 17.5 | 10 | 50 |
| | | 25 | 190 | 115 | 55 | 96 | 30 | 85 | 56 | 60 | 26 | 15 | M8 | 40 | 17.5 | 10 | 50 |
| | VA | 20 | 190 | 115 | 55 | 96 | 30 | 85 | 56 | - | 26 | 15 | M8 | 40 | 15 | 10 | 50 |
| | | 25 | 190 | 115 | 55 | 96 | 30 | 85 | 56 | - | 26 | 15 | M8 | 40 | 15 | 10 | 50 |

ACCESSORIES

Plummer block
For drum motors and idler pulleys

ACCESSORIES

Plummer block
For drum motors and idler pulleys

Plummer block

The plummer block bracket supports a simple assembly of the drum motors and idler pulleys.

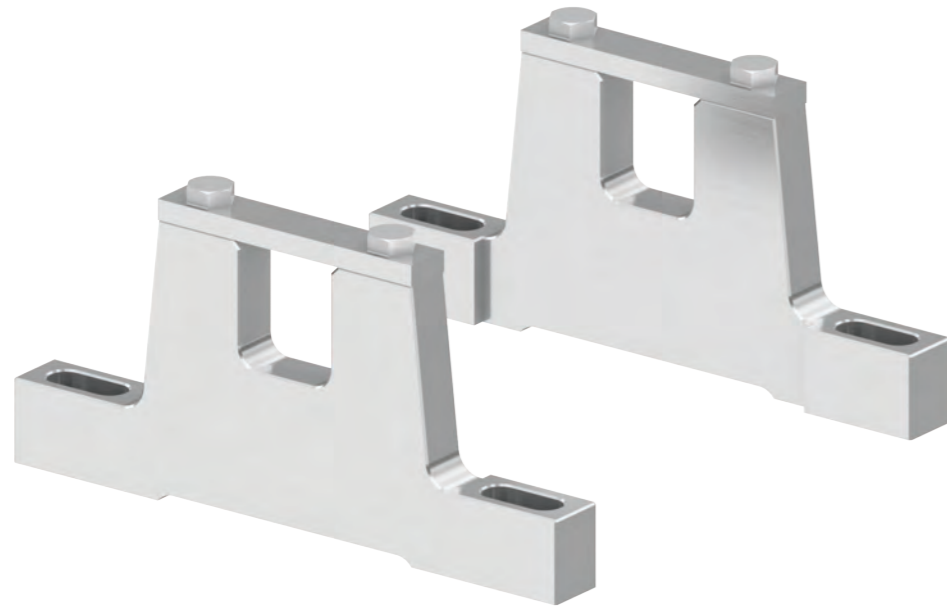

Product selection

| Drum motor | Material | Article number | | |
|------------|----------|----------------|-----------|----------|
| | | WAF 13.5 mm | WAF 20 mm | WAF 25 |
| DM 0080 | Aluminum | 61008580 | 61113900 | 61010381 |
| DM 0080 | VA | 61113949 | 61113950 | 61113951 |
| DM 0113 | Aluminum | - | 61008581 | 61115653 |
| DM 0113 | VA | - | 61115651 | 61115652 |

WAF = Width across flats

Dimensions

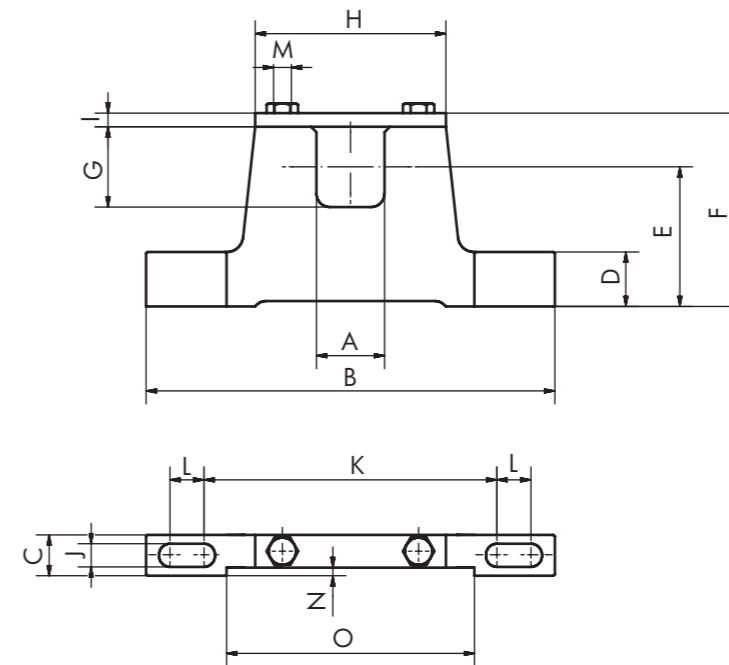

| Drum motor/idler pulley | A [mm] | B [mm] | C [mm] | D [mm] | E [mm] | F [mm] | G [mm] | H [mm] | I [mm] | J [mm] | K [mm] | L [mm] | M [mm] | N [mm] | O [mm] |
|-------------------------|--------|--------|--------|--------|--------|--------|--------|--------|--------|--------|--------|--------|--------|--------|--------|
| DM 0080 | 13.5 | 100 | 10 | 12 | 35 | 47.5 | 16.5 | 35 | 4 | 6.5 | 72.5 | 7.5 | M6 | - | - |
| | 20 | 150 | 15 | 20 | 51 | 68.5 | 24.5 | 70 | 5 | 8.5 | 108 | 12 | M6 | 3 | 91 |
| | 25 | 150 | 15 | 20 | 51 | 71 | 29.5 | 70 | 5 | 8.5 | 108 | 12 | M6 | 3 | 91 |
| DM 0113 | 20 | 150 | 20 | 15 | 42.5 | 54.5 | 24.5 | 55 | 5 | 8.5 | 118.5 | 6.5 | M6 | - | - |
| | 25 | 150 | 20 | 15 | 40 | 54.5 | 29.5 | 55 | 5 | 8.5 | 118.5 | 6.5 | M6 | - | - |



Interroll deflection rollers can be used on the driven side of conveyor belts. The deflection roller with integrated bearings has a fixed shaft and the same dimensions as a drum motor.



Technical data

| | |
|-------------------------------|---------------------------|
| Protection rate | IP69k |
| Max. belt tension | See equivalent drum motor |
| Max. belt speed | See equivalent drum motor |
| Shell length | See equivalent drum motor |
| Internal shaft sealing system | NBR |
| External shaft sealing system | PTFE |

Design versions

For idler pulleys you can choose the following design versions:

| Component | Option | Material | | | |
|---------------|---------------------------------|----------|------------|-----------------|------|
| | | Aluminum | Mild steel | Stainless steel | PTFE |
| Shell | Crowned | | ● | ● | |
| | Cylindrical | | ● | ● | |
| | Cylindrical + key for sprockets | | ● | ● | |
| End housing | | ● | | ● | |
| Shaft | | | ● | ● | |
| External seal | PTFE | | | | ● |

Versions

- Laggings for friction drive belts, page 52
- Laggings for modular plastic belts, page 58
- Laggings for positive drive solid homogeneous belts, page 62
- Sprockets for modular plastic belts (cylindrical shell with key), page 64

ACCESSORIES

Idler pulley with integrated bearings

Dimensions

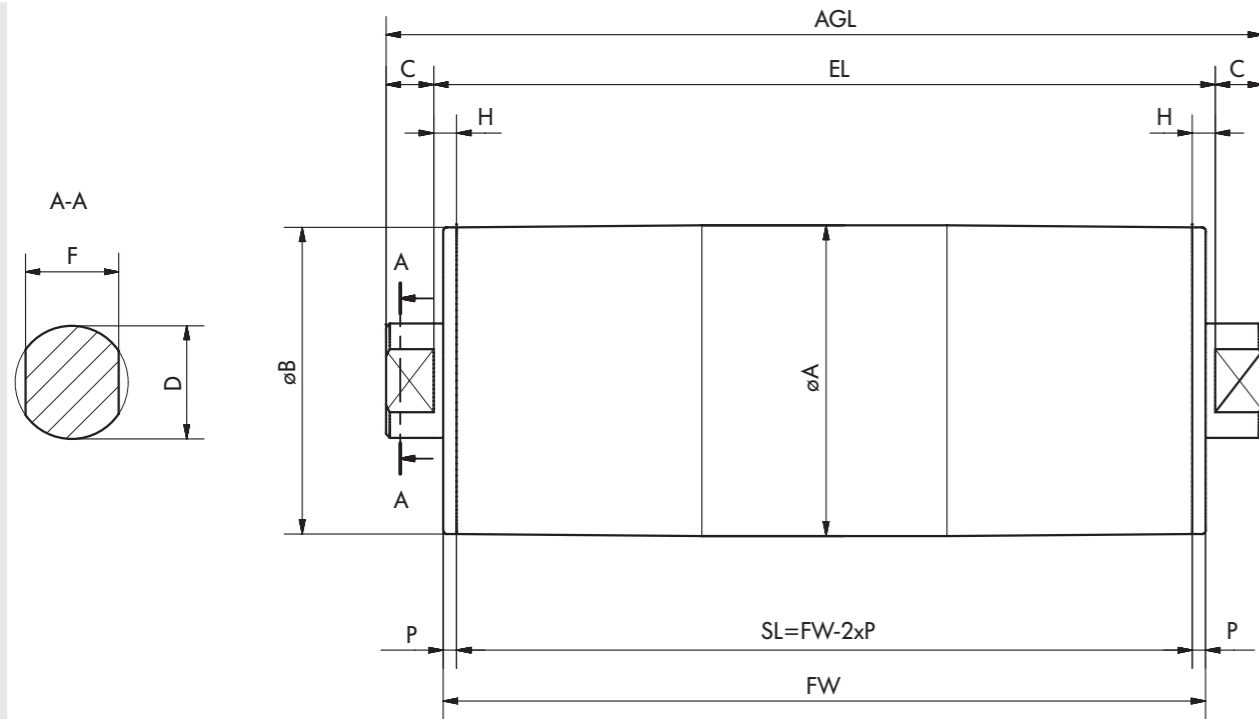

| Type | A [mm] | B [mm] | C [mm] | D [mm] | F [mm] | H [mm] | P [mm] | SL [mm] | EL [mm] | AGL [mm] |
|---------------------------|--------|--------|--------|--------|--------|--------|--------|---------|---------|----------|
| DM 0080 crowned | 81.5 | 80.5 | 12.5 | 30 | 25 | 6 | 3.5 | FW - 7 | FW + 5 | FW + 30 |
| DM 0080 crowned | 81.5 | 80.5 | 12.5 | 25 | 20 | 6 | 3.5 | FW - 7 | FW + 5 | FW + 30 |
| DM 0080 crowned | 81.5 | 80.5 | 12.5 | 17 | 13.5 | 6 | 3.5 | FW - 7 | FW + 5 | FW + 30 |
| DM 0080 cylindrical | 81 | 81 | 12.5 | 30 | 25 | 6 | 3.5 | FW - 7 | FW + 5 | FW + 30 |
| DM 0080 cylindrical | 81 | 81 | 12.5 | 25 | 20 | 6 | 3.5 | FW - 7 | FW + 5 | FW + 30 |
| DM 0080 cylindrical | 81 | 81 | 12.5 | 17 | 13.5 | 6 | 3.5 | FW - 7 | FW + 5 | FW + 30 |
| DM 0113 crowned | 113 | 112 | 25 | 30 | 25 | 10 | 3.5 | FW - 7 | FW + 13 | FW + 63 |
| DM 0113 crowned | 113 | 112 | 25 | 25* | 20 | 10 | 3.5 | FW - 7 | FW + 13 | FW + 63 |
| DM 0113 cylindrical | 112 | 112 | 25 | 30 | 25 | 10 | 3.5 | FW - 7 | FW + 13 | FW + 63 |
| DM 0113 cylindrical | 112 | 112 | 25 | 25* | 20 | 10 | 3.5 | FW - 7 | FW + 13 | FW + 63 |
| DM 0113 cylindrical + key | 113 | 113 | 25 | 30 | 25 | 10 | 3.5 | FW - 7 | FW + 13 | FW + 63 |
| DM 0113 cylindrical + key | 113 | 113 | 25 | 25* | 20 | 10 | 3.5 | FW - 7 | FW + 13 | FW + 63 |

* Available from Q4/2018

Most of the Interroll Drum Motors are used in unit handling conveyors that are transporting small packages, boxes, cardboard containers, small pallets or other material. Depending on the type of application, friction drive or positive drive belts can be used with asynchronous or with synchronous drum motors.

Examples of applications:

- Logistics, such as postal sorting and distribution centers
- Airport baggage handling
- Seafood, meat and poultry
- Bakeries
- Fruit and vegetables
- Beverage and brewing industry
- Snacks
- Weighing equipment for packages

Friction drive belts

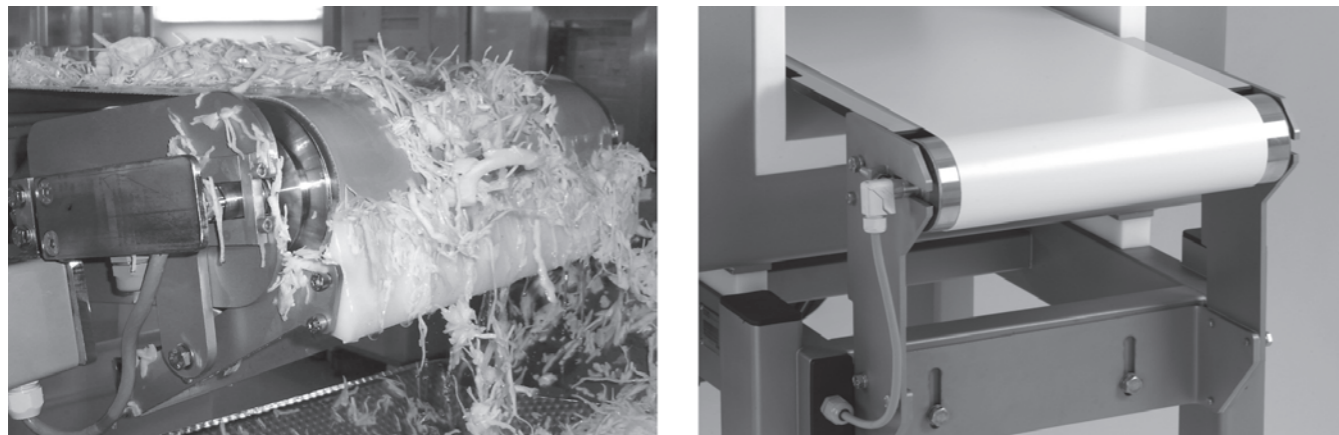

Friction drive belts are driven via the friction between drum motor and conveyor belt. The drum motor is normally crowned to prevent belt wander. The belt must be tensioned in order to transfer the torque from the drum motor. The top surface of the belt can be flat, plain or have a ribbed, grooved or diamond pattern.

Lagging

Interroll offers a broad spectrum of hot and cold-vulcanized laggings made of different materials to increase the friction between belt and drum shell. For more information, page 52.

Positive drive belts

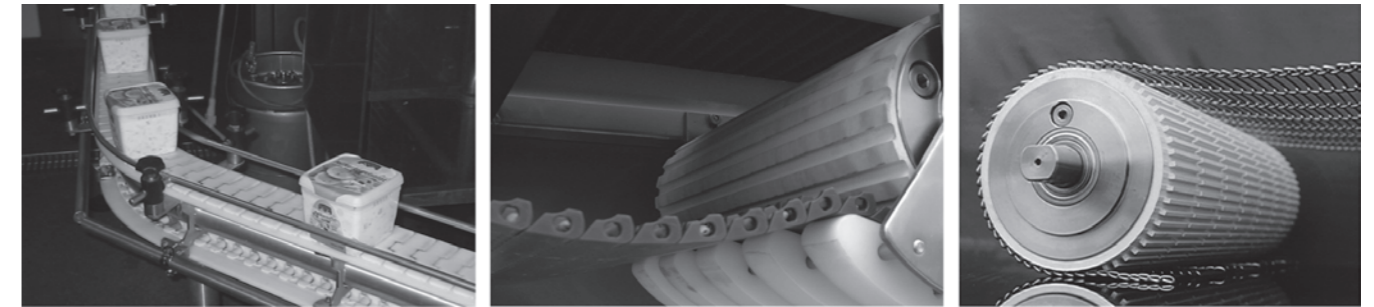

Modular plastic belts, solid homogeneous belts, steel mesh or wire belts are positively driven, i.e., with no belt tension. Since the belt has hardly any direct contact with the drum shell, the heat dissipation is less effective in these applications. For this reason, the drum motor should be used with a frequency inverter that is optimized for this application.

Positive drive belts use less power than friction drive belts, allowing longer conveyors. Because these belts are not tensioned, there is less stress on the bearings and internal parts of the drum motor resulting in a longer service life. A power reduction of 17 % is required for asynchronous motors in these applications.

Interroll recommends the use of profiled lagging wherever possible to ensure easy cleaning, evenly distributed torque transmission and torque dampening at start-up. Stainless steel sprockets can be supplied for belts where profiled lagging is not suitable.

Interroll offers a wide range of profiled lagging according to the belt manufacturers' specifications. For more information, page 62.

Non-belt applications



For applications without a conveyor belt or with a narrow belt covering less than 70 % of the drum motor face width, heat from the motor can no longer be dissipated via the belt contact. For these applications, we recommend using a 2-pole asynchronous drum motor or synchronous drum motor with frequency inverter.

Examples of non-belt applications include the following:

- Pallet roller drive and pallet transfer
- V-belt drive for driving roller conveyors
- Chain conveyors
- Narrow belts covering less than 70 % of the shell width

A power reduction of 17 % is required for asynchronous motors in these applications.

For some non-belt applications the drum motor can be mounted in a non-horizontal position. For more information, page 122.

Hygienic conditions



For food processing and other applications where hygiene is paramount we recommend the following materials, connectors and accessories:

- Stainless steel shell
- Stainless steel cover
- Stainless steel shafts
- External shaft seals made of PTFE
- Food grade synthetic oil
- NBR hot-vulcanized (FDA & EC 1935/2004)
- Molded PU, Shore hardness 82D (FDA & EC 1935/2004 only)
- A lagging of hot vulcanized NBR or molded PU should be combined only with a stainless steel shell.
- Diamond patterned lagging is not suitable for food processing applications.

Cable connectors/terminal boxes and cables

All cable connectors, terminal boxes and cables are not included in our (EC) 1935/2004 and FDA declaration. These components are considered "Not in direct contact with food stuffs" as described in the following regulations: Commission regulation (EC) No. 2023/2006 of December 22, 2006 on good manufacturing practice for materials and articles intended to come into contact with food. Article 3, definition (d): "Non-food-contact side" means the surface of the material or article that is not directly in contact with food.

FDA Food Code 2009: Chapter 1 - Purpose and Definitions - "Food-contact surface" means

- (1) A surface of equipment or a utensil with which food normally comes into contact; or
- (2) A surface of equipment or a utensil from which food may drain, drip, or splash:
 - (a) Into a food, or
 - (b) onto a surface normally in contact with food.

NSF: On request
 USDA & 3A: no compliance
 For food processing applications, Interroll recommends using cable connectors and terminal boxes in stainless steel or Technopolymer.

Hygienic design

All Interroll Drum Motors are designed in accordance with EU Directives for Hygienic Design:

- Machinery Directive (Directive 98/37/EC) Food Machinery section, Appendix 1, point 2.1 (to be replaced by 2006/42/EC)
- Document 13 EHEDG-Guideline to the hygienic design of apparatus for open processes, prepared in collaboration with 3-A and NSF International

EHEDG-compliant drum motors

Interroll Drum Motors configured with components listed below comply with EHEDG, Class I "Open Equipment". They are ideally suited for ultra-hygienic environments and tolerate high water pressure washing (IP69k):

- Stainless steel shell: cylindrical or crowned
- Stainless steel cover
- Stainless steel shafts
- Shaft seals made of PTFE
- Food grade synthetic oil

Conveyor frame

EHEDG design rules recommend the use of rust-free open conveyor frames to facilitate easy cleaning, wash down and disinfection of the conveyor, drum motor and belt. The drum motor should be mounted in the conveyor frame in such a way that there is no metal-on-metal contact between motor shaft and frame support, .e.g. by using a rubber seal between shaft and frame support. The sealing material shall be FDA and EC 1935/2004 compliant.

Cleaning materials

Cleaning specialist Ecolab has certified a 5-year minimum lifetime of materials used by Interroll when exposed to typical cleaning and disinfecting procedures using Ecolab's Topax range of products: P3-topax 19, P3-topax 686, P3-topax 56 and P3-topactive DES.



High pressure cleaning

Max. 80 °C / 80 bar for PTFE sealing with IP69k

Note: Changes in ambient temperature and humidity can cause condensation and lead to water inside the terminal box (especially in stainless steel terminal boxes). For example, this can occur when the motor is operated below 5 °C and then cleaned with hot water or steam. Interroll recommends using the cable option in such cases.

High temperatures

Interroll Drum Motors are generally cooled by dissipating heat through the contact between the surface of the drum shell and the conveyor belt. It is essential that each drum motor has an adequate thermal gradient between the internal motor and its ambient operating temperatures.

All drum motors in the catalog are designed and tested in accordance with EN 60034 (without lagging and with a belt) for use at a maximum ambient temperature of +40 °C. Any material can be used, but stainless steel has less heat dissipation.

Lagging can cause thermal overload for positive driven belts. For this reason, use motors with frequency inverters that ensure an optimum temperature. As an alternative, it is also possible to use synchronous motors. Rubber lagging for friction drive belts can also cause thermal overload. External cooling systems can also be used to prevent thermal overload.

If you need a motor for applications with ambient temperatures above +40 °C, please contact Interroll.

Low temperatures

When a drum motor is operated in low temperatures (below +2 °C), consider the viscosity of the oil and temperature of the motor while it is not running. For additional information and notes, please contact Interroll.

Anti-condensation heating for asynchronous drum motors

In ambient temperatures below +1 °C, the motor windings should be heated to regulate the oil viscosity and to keep seals and internal parts at a constant temperature.

If the motor current is switched off for some time and the ambient temperature is very low, then the motor oil becomes viscous. In these conditions problems may occur when starting the motor and at temperatures of around zero frost crystals can form on the sealing surfaces, causing oil leakage. To prevent these problems use anti-condensation heating.

The heater applies a DC voltage to the motor winding. This causes current to flow either in the two motor phases of a 3-phase motor or the main winding of a 1-phase motor. The amperage depends on the voltage applied and the winding resistance. This current creates a power loss in the winding which heats up the motor to a certain temperature. This temperature is determined by the ambient temperature and the amperage.

Information on the correct voltage is available in the motor version tables. The values listed are average values, which can be increased or decreased depending on the required motor temperature and the ambient temperature. Interroll strongly recommends determining the correct voltage by testing under actual operating conditions.

Only DC voltage may be used to heat the motor. The use of AC voltage can cause the motor to move unexpectedly, leading to serious damage or injury.

The stationary heating system should only be used when the motor is actually idle. The heating voltage must be switched off before the motor is operated. This can be ensured by using simple relays or switches.

The suggested voltages are calculated to prevent the formation of condensation. If the motor needs to be held at a specific temperature, then the stationary heating system must be set up accordingly. In this case, please contact your Interroll customer consultant.

The anti-condensation heating voltage must be connected to any two phases of a 3-phase motor. The heating current supplied by the heating system can be calculated as follows:

$$I_{DC} = \frac{U_{SH\Delta} \cdot 3}{R_{Motor} \cdot 2}$$

Fig.: Delta connection

$$I_{DC} = \frac{U_{SH\star}}{R_{Motor} \cdot 2}$$

Fig.: Star connection

Low noise



All Interroll Drum Motors excel with relatively low noise development and vibrations. The performance levels are not specified or guaranteed in this catalog because they can vary depending on the type of motor, number of poles, speed and application. For specific low-noise applications, please contact your Interroll customer consultant.

Altitudes above 1000 m

Operating a drum motor at an altitude of more than 1000 m may result in power loss and thermal overload due to the low atmospheric pressure. This must be considered when calculating your power requirement. For more information, please contact your Interroll customer consultant.

Supply voltage (asynchronous drum motors only)

Using 3-phase 50 Hz motors in a 60 Hz supply system with the same voltage

- Motor rated: 230/400 V – 3 ph – 50 Hz
- Supply voltage: 230/400 V – 3 ph – 60 Hz

Using a 3-phase 50 Hz motor in a 60 Hz supply system will increase the frequency, and therefore the speed, by 20 %. If the other rated motor parameters are to be kept constant, a 20 % higher input voltage is required (U/f law). However, if this 20 % higher voltage is not supplied, all voltage-dependent parameters will be affected in accordance with the following table:

System voltage = rated motor voltage

| Motor data | | | |
|------------------|----------------|-------|--------|
| Power | P | kW | 100 % |
| Rated speed | n_n | 1/min | 120 % |
| Rated torque | M_n | Nm | 83.3 % |
| Starting torque | M_A | Nm | 64 % |
| Pull-up torque | M_S | Nm | 64 % |
| Pull-out torque | M_K | Nm | 64 % |
| Rated current | I_N | A | 96 % |
| Starting current | I_A | A | 80 % |
| Power factor | $\cos \varphi$ | | 106 % |
| Efficiency | η | | 99.5 % |

| Supply voltage | Motor rating |
|----------------|--------------|
| 230/400 V | 230/400 V |
| 3 ph | 3 ph |
| 60 Hz | 50 Hz |

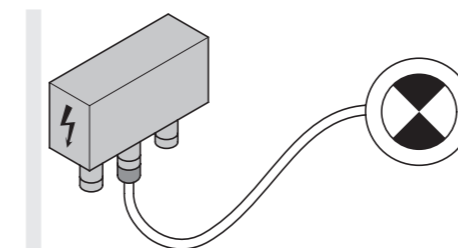

AMBIENT CONDITIONS

Using 3-phase 50 Hz motors in a 60 Hz supply system with 15/20 % higher voltage

- Motor rated: 230/400 V – 3 ph – 50
- Supply voltage: 276/480 V - 3 ph - 60 - 2 and 4 poles (motor voltage + 20 %)

Using a 3-phase 50 Hz motor in a 60 Hz supply system with 20 % higher voltage will increase the frequency and therefore the speed by 20 %, but will maintain all the rated motor parameters subject to small variations (U/f law).

Note: If the supply voltage is increased by 15 % compared to the motor voltage, the actual motor output decreases to 92 % of the original motor output.

Supply voltage = 1.2 x rated motor voltage (for motors with 2 and 4 poles)

| Motor data | | | |
|------------------|----------------|-------|-------|
| Power | P | kW | 100 % |
| Rated speed | n_n | 1/min | 120 % |
| Rated torque | M_n | Nm | 100 % |
| Starting torque | M_A | Nm | 100 % |
| Pull-up torque | M_S | Nm | 100 % |
| Pull-out torque | M_K | Nm | 100 % |
| Rated current | I_N | A | 102 % |
| Starting current | I_A | A | 100 % |
| Power factor | $\cos \varphi$ | | 100 % |
| Efficiency | η | | 98 % |

| Supply voltage | Motor rated |
|----------------|-------------|
| 230/480 V | 230/400 V |
| 3 ph | 3 ph |
| 60 Hz | 50 Hz |

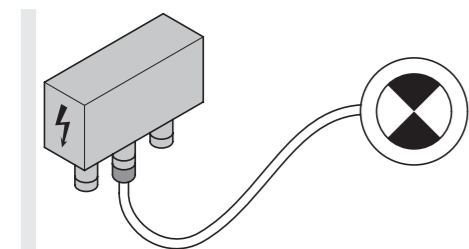

Interroll offers a wide range of industrial solutions for its drum motors. In this chapter, only the most important solutions will be explained.

General logistics

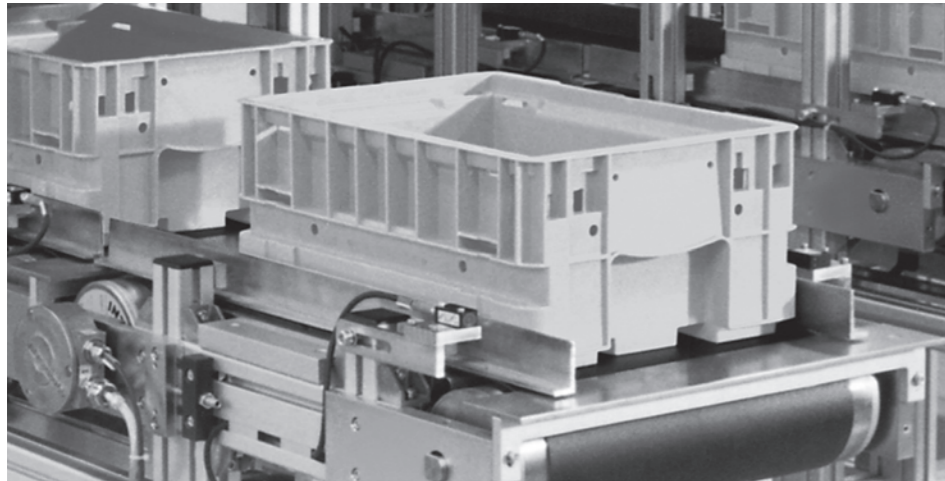

Conveying in logistics, warehousing and storage sectors covers a wide spectrum of applications in industries, such as electronics, chemicals, food, automotive and general manufacturing. All motors in this catalog are suitable for general logistics applications.

High performance and dynamic conveying



Modern Industry today expects high efficiency and increased productivity as well as fast bus communication between zones and zero maintenance. Interroll provides the perfect drives for high performance applications that typically use smart belts, packaging machines, weighing

machines and sorting equipment. This type of equipment requires high torque, fast acceleration/deceleration, dynamic braking and bus communication. If more control is needed, the motor can be fitted with an encoder to run it as a servo-drive.

Food processing



Interroll Drum Motors are ultra-hygienic and easy to clean. All drum motors for food processing comply with EC 1935-2004 and FDA. NSF-compliant motors are available on request. Interroll is a member of the EHEDG (European Hygienic Engineering Design Group).

Consider the ambient conditions before choosing drum motor versions, options and accessories.

Suitable drum motors

- For friction drive belts use an asynchronous drum motor.
- For positive drive belts use either a drum motor for applications with positive drive belts or no belts, or an asynchronous drum motor with frequency inverter.
- A synchronous drum motor can also be used for all applications.

Torque transmission

For moist or wet food applications with friction drive belts Interroll recommends rubber lagging on the drum motor to improve the friction between the belt and drum shell. In continuously wet conditions, longitudinal grooved lagging can be used to dissipate the water flow and improve the grip.

Options and accessories

- Stainless steel or other materials approved for food or hygienic applications.
- Drum motors for food processing are supplied with food-grade oil.
- Interroll offers a variety of hot-vulcanized lagging materials approved for use in food processing (FDA and EC 1935/2004).
- Hot-vulcanized NBR and molded PU lagging has a longer service life, withstands higher torques and is easier to keep clean than cold-vulcanized lagging.

Conveyor frame

EHEDG design rules recommend the use of rust-free open conveyor frames to facilitate easy cleaning, wash down and disinfection of the conveyor, drum motor and belt. The drum motor should be mounted in the conveyor frame in such a way that there is no metal-on-metal contact between motor shaft and frame support, e.g. by using a rubber seal between shaft and frame support. The sealing material shall be FDA and EC 1935/2004 compliant.

Cleaning Materials

Cleaning specialist Ecolab has certified a 5-year minimum lifetime of materials used for Interroll Drum Motors when exposed to typical cleaning and disinfecting procedures using Ecolab's Topax range of products: P3-topax 19, P3-topax 686, P3-topax 56 and P3-topactive DES.

Airport logistics



Airport applications, such as conveyors at check-in, X-Ray machines and scanning equipment, require low noise and frequent starts and stops. Most applications use friction drive belts made of PU, PVC or rubber.

A belt conveyor is designed primarily to transport or transfer materials from one place to another. In its simplest form, a belt conveyor normally consists of a longitudinal frame with a drum motor at one end and an idler pulley at the other end around which a continuous belt revolves. The belt, which carries the materials, can be supported either by rollers or a steel, wood or plastic slider bed. This chapter on design guidelines is subdivided into two sections: friction drive belt conveyors and positive drive belt conveyors, since each type requires a different method of torque transfer.

Friction drive belt conveyors

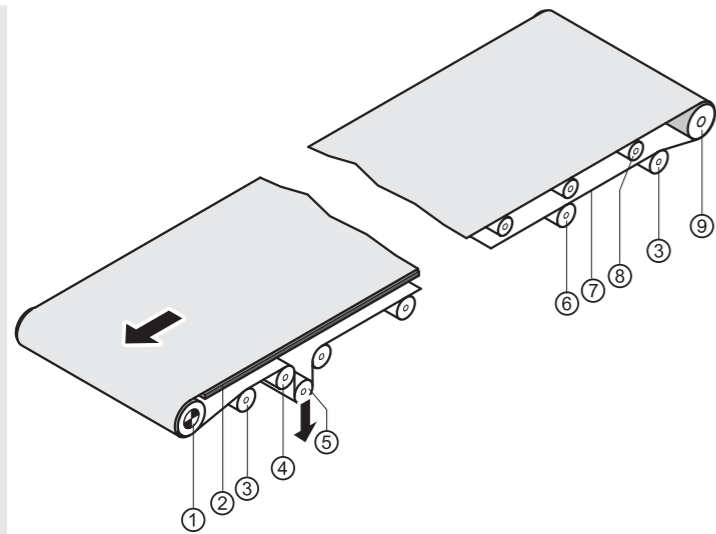

- 1 Drum motor
- 2 Slider bed
- 3 Tie-in roller
- 4 Steering idler
- 5 Tensioning roller
- 6 Support roller
- 7 Conveyor belt
- 8 Carrying idler
- 9 Idler pulley

Friction drive belt conveyors, e.g. rubber, PVC or PU flat belts, rely on high friction between the drum motor and belt and sufficient belt tension in order to transmit the torque from the drum motor to the belt. For typical friction factors, refer to the table page 111.

Torque transmission

Normally the steel crowned shell of the drum motor is sufficient to transmit the torque but care must be taken not to over-tension the belt, which could damage the drum motor shaft bearings or even the belt itself.

Belt tension

The conveyor belt should only be tensioned in line with the manufacturer’s recommendations and the tension should only be enough to drive the belt and load without belt slip. Over-tensioning can damage the drum motor and belt. Maximum belt tensions for the drum motors can be found in the product pages of this catalog.

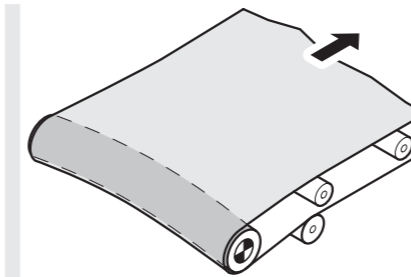

Fig.: Damaged drum motor due to over-tensioning

Lagging

To improve the torque transmitted from the drum motor to the belt, rubber lagging can be applied to the drum shell to produce more grip.

A smooth lagging or a lagging with diamond pattern is well suited for dry applications. It is also possible to use laggings with grooves or other laggings. Longitudinal grooved lagging is advisable to dissipate water in food processing or wet applications. Diamond patterned lagging can be used for non-food wet applications.

When external belt tracking devices are installed, cylindrical shells can be used to prevent opposing influences.

Additional friction factor

Depending on the belt material, the friction between conveyor belt and drum motor can vary.

Consider the following friction factors when calculating the belt tension:

| Drum motor surface | Conditions | Belt material | | | |
|--------------------|------------|-------------------|------|-------------------|---------------------------|
| | | Frictioned rubber | PVC | Polyester fabrics | Impregnation with Ropanol |
| Steel | Dry | 0.25 | 0.35 | 0.20 | 0.25 |
| | Wet | 0.20 | 0.25 | 0.15 | 0.20 |
| Smooth lagging | Dry | 0.30 | 0.40 | 0.25 | 0.30 |
| Grooved lagging | Wet | 0.25 | 0.30 | 0.20 | 0.25 |

Belt wrap angle

There is another way to improve the torque transmitted from the drum motor to the belt: You can increase the angle of belt wrap around the drum motor. The belt wrap angle is measured in degrees. A larger belt wrap angle gives better traction between the belt and drum motor, and the belt requires less belt tension. A minimum angle of 180° is generally recommended to transfer the full torque to the belt. Increasing the angle to 230° or more is indeed possible to reduce the belt tension and, therefore, the wear of drum motor and belt.

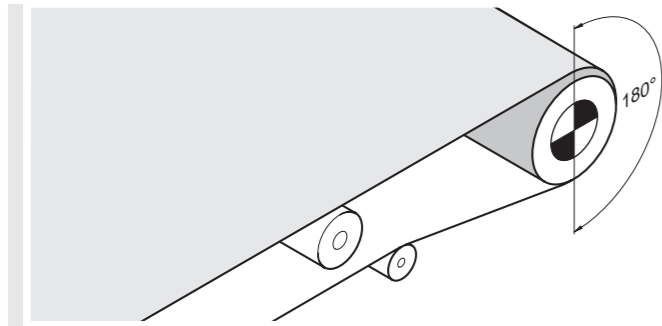

Fig.: Minimum belt wrap angle for friction drive belt conveyors

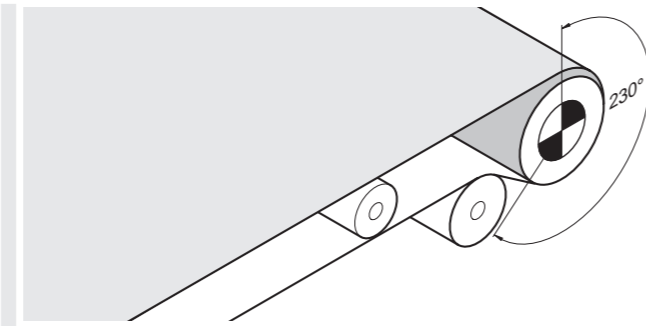

Fig.: Increased belt wrap angle for friction drive belt conveyors

Roller bed conveyor

Due to their lower friction, roller bed conveyors require less power, less belt tension and are therefore more efficient than slider bed conveyors. Roller bed conveyors are especially suitable for longer conveyors with heavy loads.

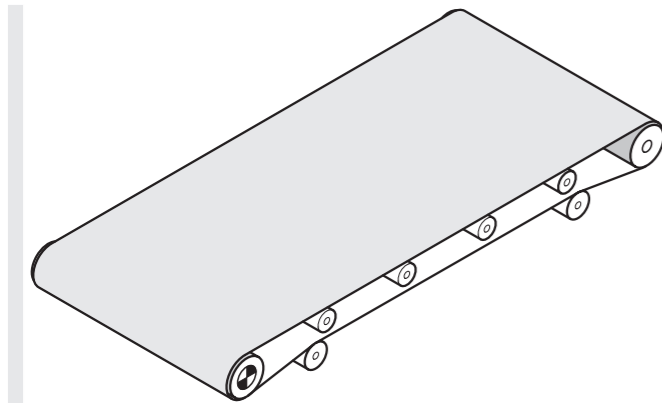

Fig.: Roller bed conveyor

Slider bed conveyor

Belt conveyors using a slider bed have more friction and require higher power and belt tension than belt conveyors with rollers and are therefore less efficient. However, the transported goods lie on the belt with greater stability. Due to its simple construction, it is a lower cost option than the roller bed conveyor.

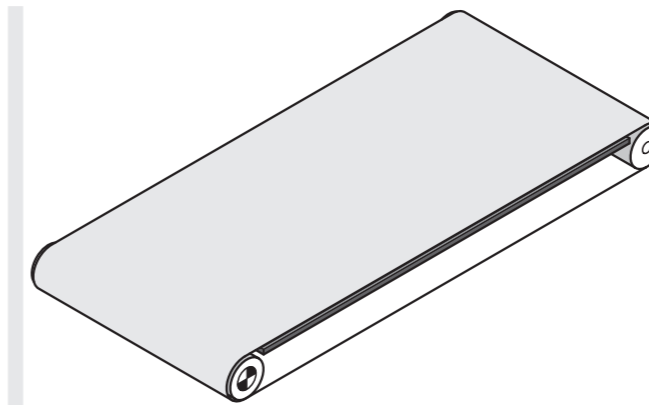

Fig.: Slider bed conveyor

Drive positions

The drum motor is usually positioned at the head or discharge end of the conveyor but can be positioned elsewhere to suit the application or design.

Head drive

The head drive positioning (discharge end) is the most common and preferred option for non-reversible conveyors and is ideal because it is simple to design and easy to install. Furthermore most of the belt tension is on the carrying side and allows the drum motor to transfer its full torque to the belt.

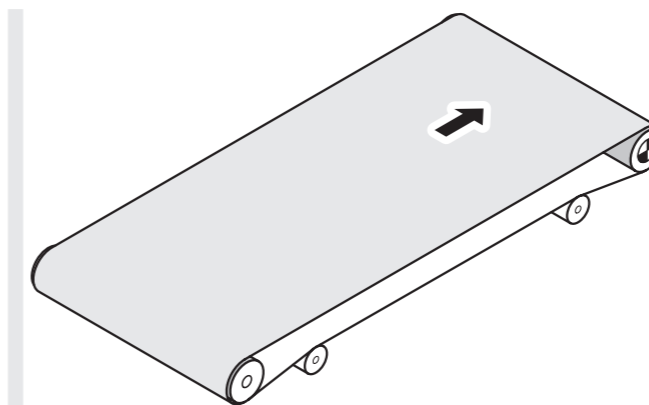

Fig.: Non-reversible conveyor with head drive

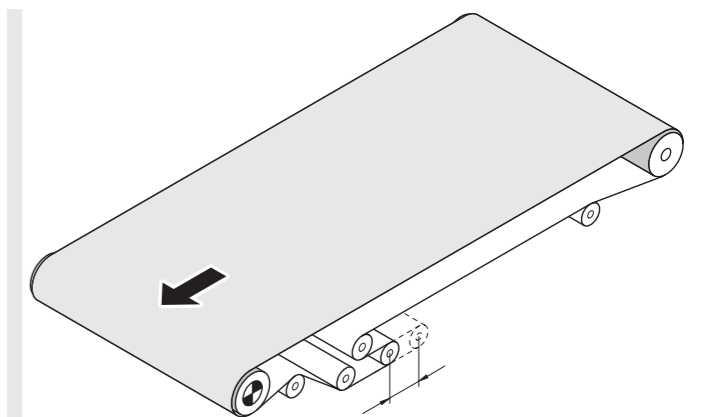

Fig.: Optional design for non-reversible long conveyor with center take-up

Tail drive

A conveyor's tail end (loading or receiving end) is not the ideal drive position as the drum motor is pushing the carrying side of the belt and more tension is applied to the return side. Therefore, the full torque of the drive may not be applied. This type of drive can lead to belt waves (belt lifting on the top side), jumping and undesirable belt wander. If a tail drive is necessary, it is recommended only for use with short friction drive belt conveyors of 2 to 3 meters in length with light loads. (It is not recommended for positive drive belts.)

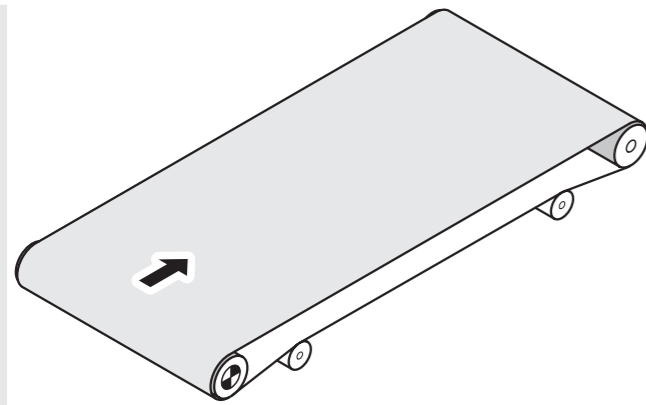

Fig.: Short friction drive belt conveyor with tail drive

Center drive

A center drive can be used for longer belt conveyors where a large diameter drum motor is required and there is insufficient space available at the head end. The center drive can also be used for reversible conveyors because the belt tension is distributed more evenly between the carrying and return side of the belt. Belt tracking issues for forward and reverse operation can be minimized.

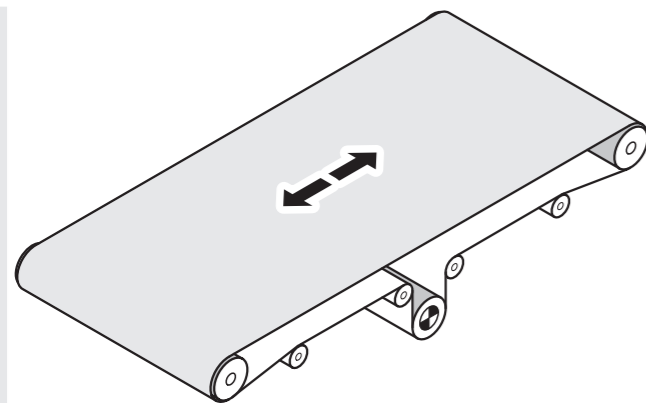

Fig.: Long belt conveyor with center drive

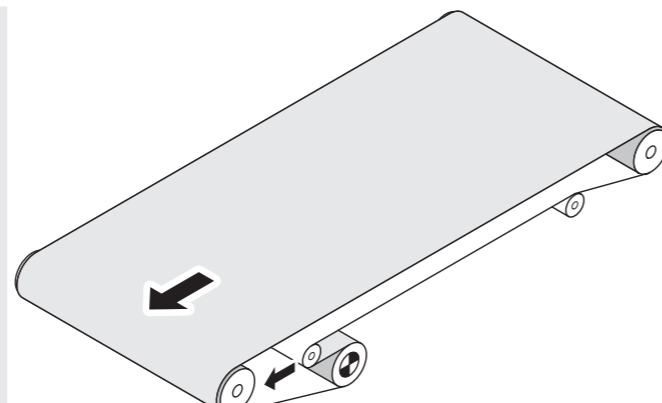
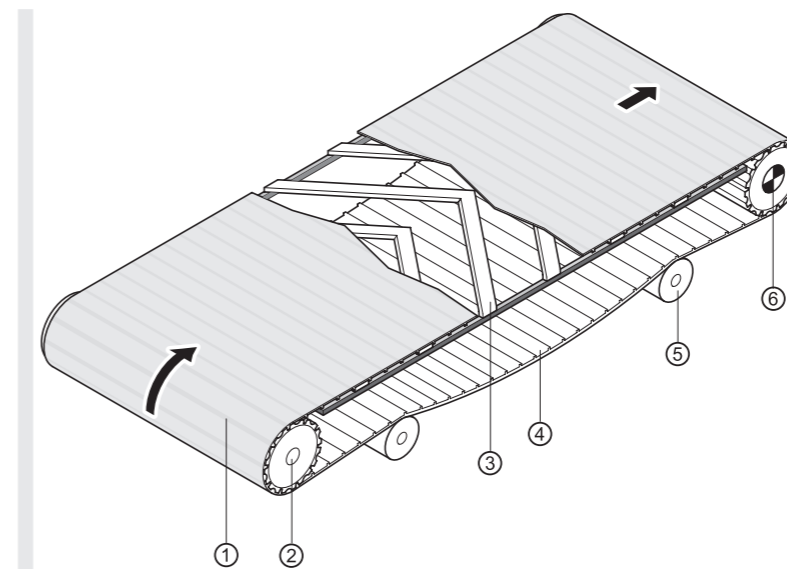

Fig.: Center drive for long belt conveyor with increased belt wrap

Reversible drive

Interroll Drum Motors are suitable for reversing unless fitted with a backstop. However, the motor control must be designed in such a way that the drum motor is brought to a complete standstill before reversing, otherwise serious damage to the gear box could occur. Drum motors with a backstop may be used only for conveying in one direction. The direction is indicated by an arrow on the end housing.

Positive drive belt conveyors



- 1 Modular plastic belt
- 2 Idler pulley with sprockets
- 3 Support slats
- 4 Catenary sag
- 5 Support rollers
- 6 Drum motor

Positive drive belt systems have a lower power consumption than friction drive belts, enabling longer conveyor constructions. As there is no belt tension, there is less stress on the drum motor bearings. Since the belt has no direct contact with the drum shell, the heat dissipation is less effective in these applications. For this reason, the drum motor should be used with a frequency inverter that is optimized for this application. Alternatively, motors for applications with positive drive belts or no belts can be used.

Examples of positive driven belts include the following:

- Modular plastic belts
- Positive drive solid homogeneous belts
- Steel slatted belts
- Steel mesh or wire belts
- Toothed belt
- Chain conveyors

Positive drive belt installations can be quite complex and are not discussed in detail in this catalog. Please refer to the belt supplier's instructions and contact Interroll if further advice is required.

Torque transmission

Drum motors for positive drive belt conveyors are normally supplied with full-width machined rubber lagging that engages the profile of the conveyor belt on the underside. Alternatively, a cylindrical drum shell with a laterally welded key can be supplied enabling any type of steel, stainless steel or plastic sprocket wheels to be fitted to the shell. The number of sprockets depends on the belt width and load but there must be a minimum of three. The calculation of the number of sprockets required can be found in the belt manufacturer's catalog. Due to the thermal expansion of the belt, all sprockets supplied by Interroll are floating and therefore it may be necessary to guide the belt using side guides built into the conveyor frame in order to achieve a center belt tracking. As an alternative, Interroll can supply a fixed sprocket positioned in the center of the belt.

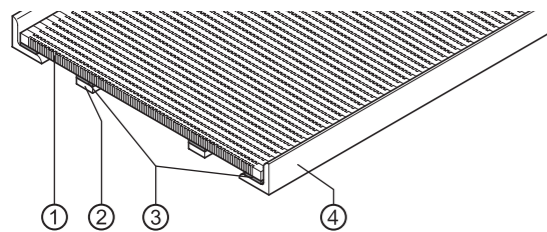

- 1 Belt
- 2 Support slats
- 3 Wear strips
- 4 Side supports/side guides

Fig.: Belt tracking

Belt tension

Due to its positive drive, the conveyor belt generally requires no belt tension and uses only the gravity from its own weight to engage the lagging or sprocket profile. On the return side, the belt should hang loose to accommodate the changing length of the belt due to thermal expansion and contraction. The installation and conveyor design should comply with the belt manufacturer's recommendations.

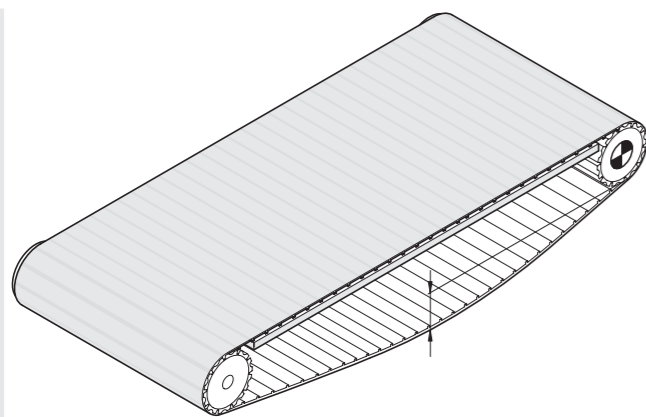

Fig.: Short conveyor without support rollers on the return belt

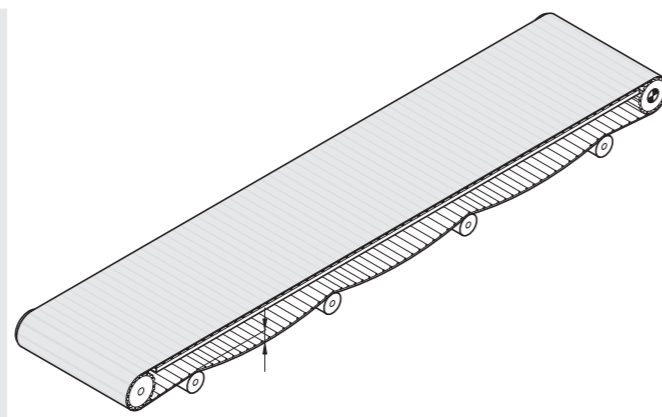

Fig.: Medium and long conveyor with catenary sag and support rollers on the return belt

Velocity factor

The increased diameter of the drum motor when fitted with lagging or sprockets will affect the rated speed of the motors shown in this catalog. In order to calculate the final belt speed, please use the following calculation. The velocity factor VF can be found in the Options section, page 59.

$$V_{\text{belt}} = V_{\text{dm}} \times VF$$

- V_{belt} = Belt speed
- V_{dm} = Rated speed of drum motor
- VF = Velocity factor

The torque is transmitted directly from the drum shell via the lagging or indirectly through the key and sprockets to the belt. This transfers up to 97 % of the mechanical output onto the belt. In start-stop applications, the use of a soft start function or frequency inverter will increase the lifespan of the belt, sprockets and gear box.

Belt pull correction factor

When using lagging or sprockets, the rated belt pull of the drum motor will be reduced. The actual belt pull is calculated as follows:

$$\text{Corrected belt pull} = \text{Rated belt pull} / VF$$

Drive positions

For positive drive belt conveyors either a head drive or center drive is possible.

Head drive

The drum motor should be positioned at the head (discharge end) of the conveyor so that the carrying side of the belt is pulled under tension.

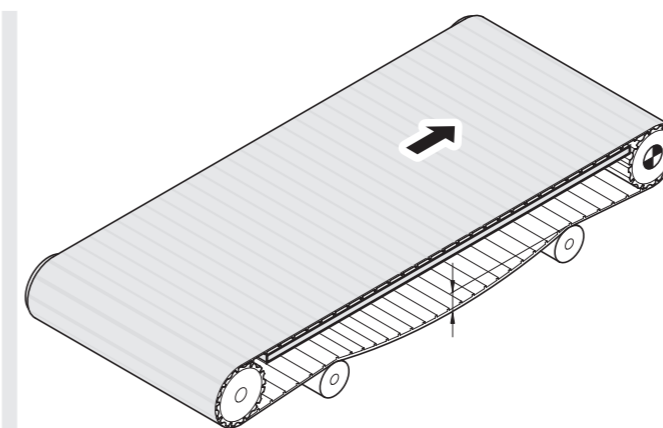

Fig.: Head drive for positive drive belt conveyors

Tail drive

Tail drives are not recommended. If the drum motor is located at the tail end (loading side) of the conveyor and attempts to push the belt, then the belt tension at the return belt is greater than at the carrying side of the belt. The belt "jumps" over the profile of the lagging or the sprockets and forms buckles in the excessive belt length – a safe transport of the material is no longer ensured.

Center drive

Center drives can be used for long unidirectional conveyors or for reversible conveyors. In the case of reversible conveyors, great care and attention is required for their design. Please contact the belt manufacturer for advice.

Other conveyors

Inclined conveyors

Inclined conveyors require more power and higher belt tension than horizontal conveyors to move the same load. A backstop should be considered for single direction inclined conveyors to prevent rollback of the belt and load.

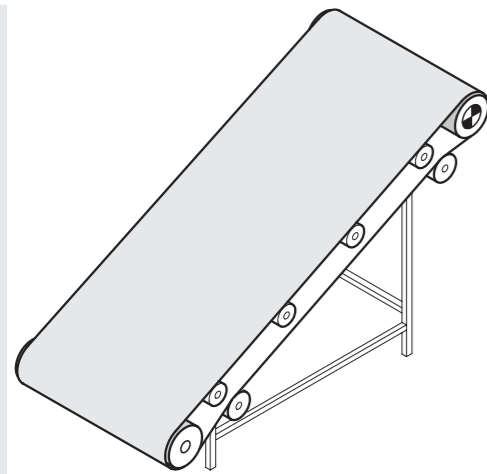

Fig.: Inclined conveyor

Reversible inclined or declined conveyors

An electromagnetic brake should be considered to prevent accidental reversal and rollback of the belt and load. To reduce acceleration and over-run of the belt and load on a declined conveyor calculate the power required as for an inclined conveyor.

Knife-edge conveyors

Knife edges reduce the gap between the transfer points of two conveyors. However, with friction drive belt conveyors, knife edges can severely increase the belt pull and tension required to overcome the increased friction between belt and knife edge. To reduce this friction the belt transfer angle should be increased as much as possible and a roller with a small diameter should replace the knife edge.

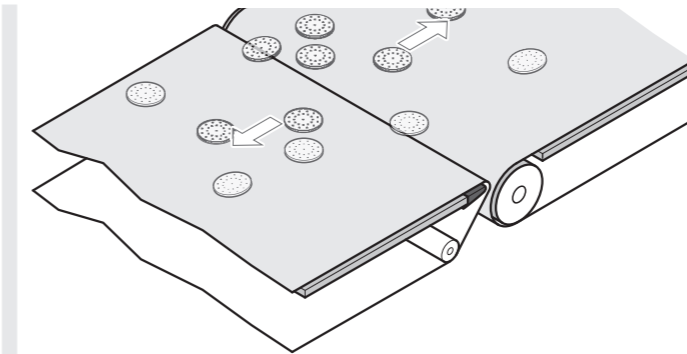

Fig.: Knife-edge conveyor

Food processing conveyors

EHEDG design rules recommend the use of rust-free open conveyor frames to facilitate easy cleaning, wash down and disinfection of the conveyor, drum motor and belt.

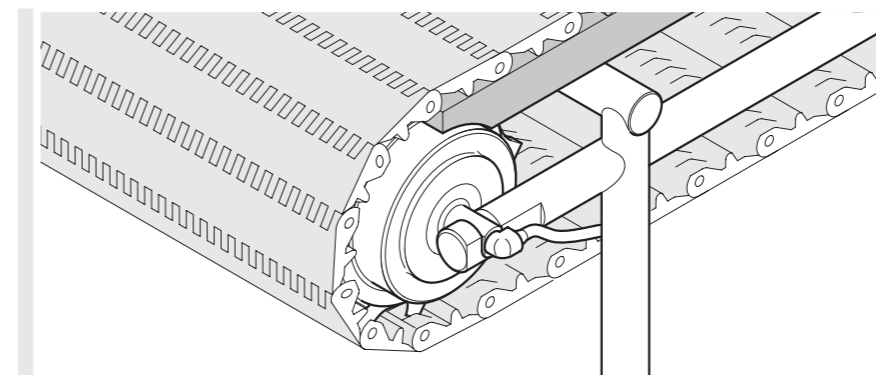

Fig.: Open conveyor design for hygienic cleaning

Plough and diverter units

If the drum motor is installed in a plough or diverter unit, it is frequently installed in a vertical position. This requires ordering a special motor design.

Frequent starts/stops

Frequent starts and stops can cause thermal overload of the motor and premature wear of the gear box, reducing the lifespan of the drum motor. In applications such as these, Interroll recommends the use of a frequency inverter to optimize the heat loss of the motor and a soft-start function to reduce the start-up load on the gear box. Synchronous or asynchronous drum motors with a frequency inverter are ideal for these applications.

Control systems

Interroll supplies brakes, backstops, encoders and frequency inverters for its range of drum motors.

What drive control system do you need?

As with any drive system, when you select a drum motor, you also must decide on the type and scope of control you will need to optimize your application. You should therefore select a motor and control system that ensures efficient and trouble-free operation right from the outset. Interroll offers a series of user-friendly drive and control solutions in its standard product range.

Control guide matrix

| | AC asynchronous motors | | AC permanent magnet synchronous motors | |
|-----------------------------------|-----------------------------------|---------------------------------------|---|---|
| | Direct connection to power supply | Frequency inverter from third parties | Frequency inverter from third parties or servo driver | Frequency inverter or servo driver recommended by Interroll |
| Direct connection to power supply | ● | | | |
| Voltage-controlled frequency | | ● | | |
| Sensorless vector control | | ● | ● | ● |
| Control loop closed | | ● | ● | ● |

Speed setting

The drum motor and therefore the conveyor belt speed will be influenced by the load, belt tension and rubber lagging thickness. Speeds provided in the product pages are based on rated load and accurate to $\pm 10\%$; for more accurate speeds use a frequency inverter/drive control to overcome these influences. For precise speeds use a frequency inverter/drive control combined with an encoder or other feedback device. Frequency inverters can also be used with asynchronous motors to increase the rated speed. However, the available torque will then be reduced starting at a frequency of 50 Hz. Synchronous drum motors with a suitable frequency inverter will offer solutions for most of these issues and can increase performance, throughput and efficiency.

For asynchronous drum motor brakes and backstops, see page 68.

Merges transfers and in-feed control

For asynchronous drum motors use a frequency inverter with DC braking (with or without encoder) to control the merge process. Alternatively, for precise, dynamic control and/or high throughput, use a synchronous drum motor.

Feedback system

Use an integrated encoder or other feedback device for precise speed and positioning data (see page 75).

Operating modes

The following operating modes comply with IEC 60034-1.

Continuous running duty S1

Operation at constant load which is long enough to reach a thermal steady-state condition.

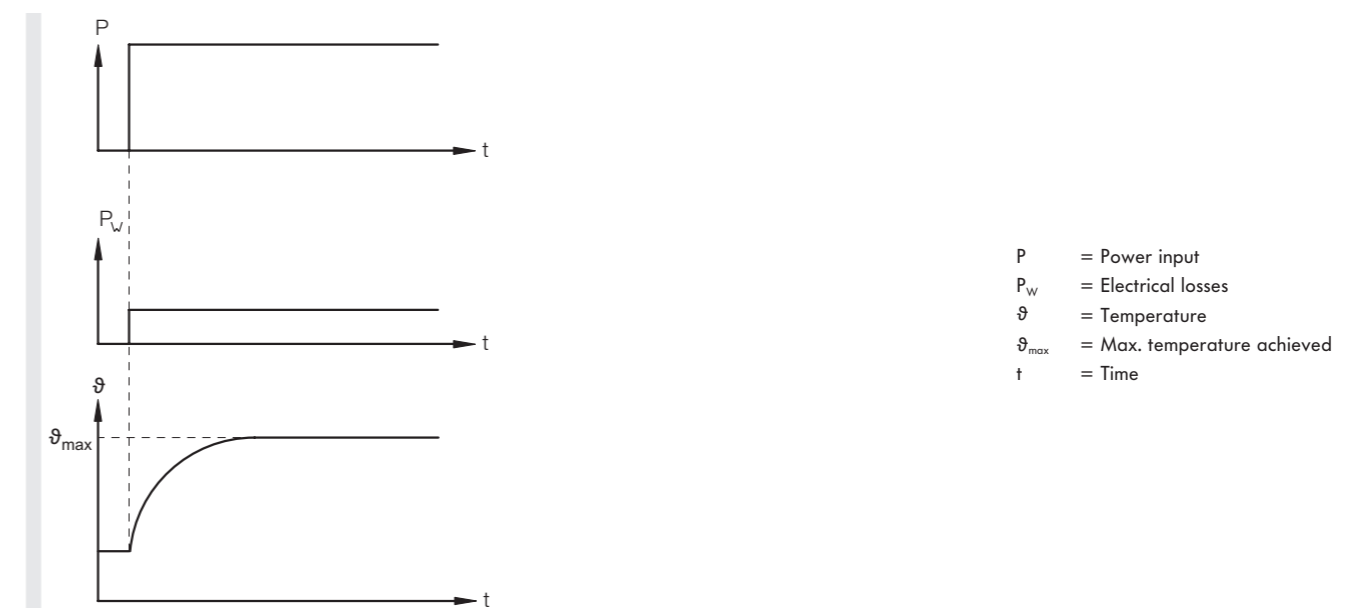

The majority of Interroll Drum Motor windings with an efficiency of over 50 % are suitable for operating mode S1 and continuous running duty. Please refer to the electrical data tables for standard motors and motors for applications with positive drive belts or no belts. The value is listed with the symbol η for efficiency.

S2 to S10

For operating modes S2 to S10, consider the duty cycles and consult Interroll.

Mounting requirements

Horizontal mounting

A drum motor is normally mounted horizontally – parallel to the idler pulley and perpendicular to the conveyor frame – to ensure that the belt will run centrally without belt wander.

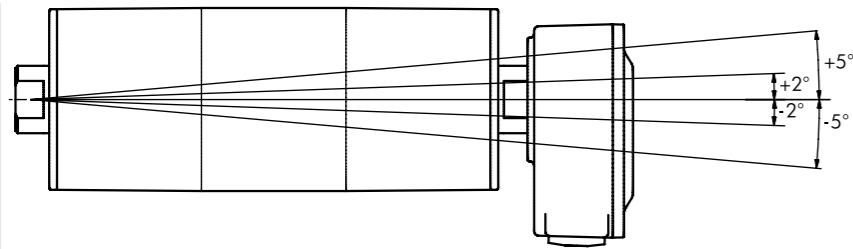

All drum motors must be mounted within $\pm 5^\circ$ of the horizontal.

Non-horizontal mounting

This requires a special motor design. The cable connection must always be at the top and a specific volume of oil is also needed for non-horizontal drum motors.

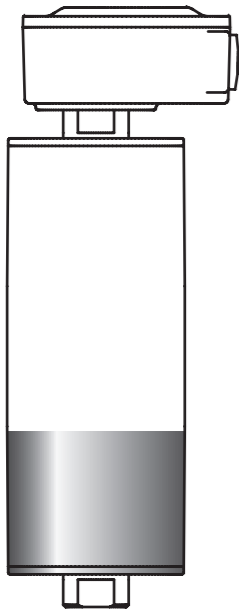

Examples

- Carton turning
- Plough transfer units
- Deflector conveyors

Mounting brackets

The mounting brackets must be strong enough to withstand the drum motor belt pull and its start-up torque. They must be fully supported and fastened to the conveyor frame so that the shaft ends do not move or deform. Shaft end key flats must always be fully supported by the brackets.

Use the mounting brackets specified for each drum motor model – see accessories starting at page 80.

Axial play

The axial play between the shaft key flats and the mounting brackets must be 1.0 mm to allow for component heat expansion.

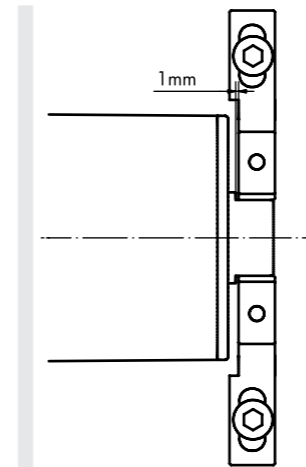

Fig.: Maximum axial play

Torsion play

The torsion play between the shaft key flats and the mounting brackets must be no more than 0.4 mm.

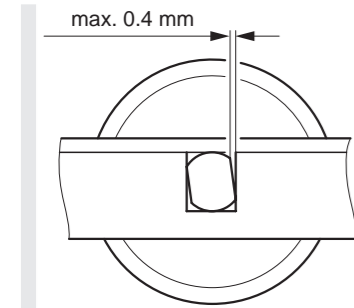

Fig.: Maximum torsion play

There must be no clearance between the shaft key flats and mounting bracket if the drum motor is to be used for frequent reversible operations or a large number of starts and stops.

Supported length

At least 80 % of the key flats must rest on the mounting bracket.

Other mounting devices

The drum motor can also be installed directly in the conveyor frame without mounting brackets. In this case, the shafts must rest in recesses in the conveyor frame that have been reinforced accordingly to meet all of the conditions listed above.

Belt adjustment

Drum motors for friction drive belts are normally supplied with crowned shells in order to ensure central belt tracking and prevent misalignment of the belt during operation. However, the belt must be checked and adjusted at its initial start up and maintained as necessary.

Diagonal check

The conveyor side frames must be parallel to each other and level on both sides ensuring the drum motor fits exactly at 90 degrees square to the frame.

This can be checked using the following procedure:

- The difference in length of the two diagonals must not be more than 0.5 %.
- The diagonals are measured from the drum motor shaft to the idler pulley shaft or from belt edge to belt edge.

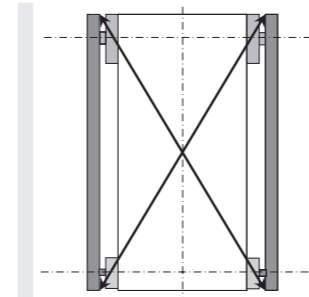

Fig.: Diagonal check

Belt position

The underside of the belt should be flush with the conveyor slide or roller bed and must not be more than 3 mm above these.

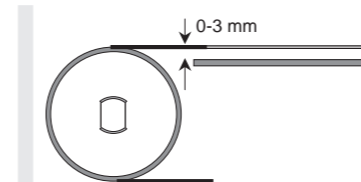
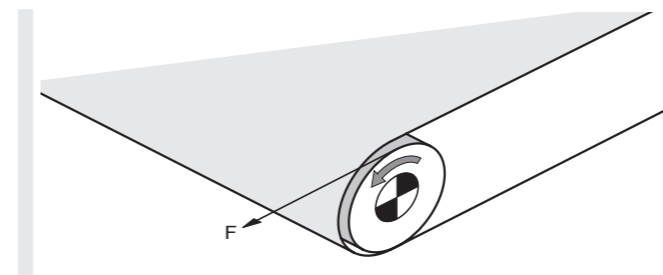

Fig.: Maximum distance between belt and conveyor bed

Misaligned drum motors, belts or idler pulleys may cause high friction and overheat the drum motor. This may also result in premature wear of the belt and lagging.

Belt pull

The rated belt pull, power and speed for each drum motor version are shown in this catalog.



You can calculate the belt pull F using the following formulas.

The formulas are only intended as guidelines since they are based on typical operating conditions. The effect of additional friction from the following factors is not taken into account:

- Hoppers
- Rubber seals
- Cleaning devices, such as ploughs, scrapers and brushes
- Friction between the product and side guides

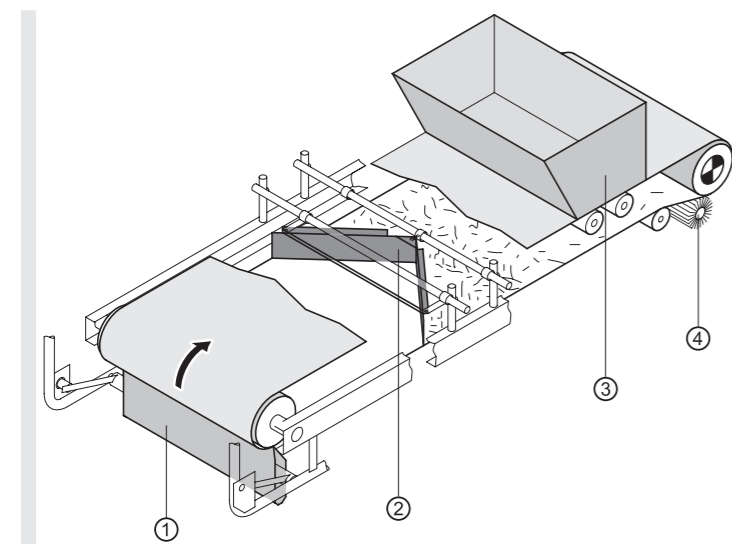

- 1 Scraper
- 2 Plough
- 3 Hopper
- 4 Brush

Belt pull calculation (F)

$$F = F_0 + F_1 + F_2 + F_3 + \text{safety factor}$$

Please add a safety factor of 20 % to this calculation.

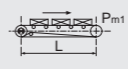
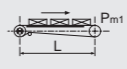
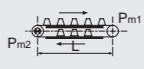
| Conveying system |  Roller bed conveyor |  Slider bed conveyor |  Double slider bed conveyor |
|--|---|---|--|
| Force without load | $F_0 = 0.04 \cdot g \cdot L \cdot (2 P_n + P_{pr})$ | $F_0 = g \cdot L \cdot P_n \cdot C_2$ | $F_0 = g \cdot L \cdot P_n \cdot (C_2 + C_4)$ |
| Force to convey materials horizontally | $F_1 = 0.04 \cdot g \cdot L \cdot P_{m1}$ | $F_1 = g \cdot L \cdot P_{m1} \cdot C_2$ | $F_1 = g \cdot L \cdot (P_{m1} \cdot C_2 + P_{m2} \cdot C_4)$ |
| Force to convey materials on incline | $F_2 = g \cdot H \cdot P_{m1}^*$ | $F_2 = g \cdot H \cdot P_{m1}^*$ | $F_2 = g \cdot H \cdot (P_{m1} - P_{m2})^*$ |
| Accumulation | $F_3 = g \cdot L \cdot P_{m1} \cdot C_1$ | $F_3 = g \cdot L \cdot P_{m1} \cdot C_1$ | $F_3 = g \cdot L \cdot (P_{m1} \cdot C_1 + P_{m2} \cdot C_3)$ |

- P_n in kg/m = Belt weight per meter
- P_{pr} in kg/m = Weight of rotating parts of the belt conveyor (carrying and return section) per meter length
- P_{m1} in kg/m = Weight of the conveyed product on the carrying section, for each meter of length of the belt conveyor
- P_{m2} in kg/m = Weight of the conveyed product on the return section, for each meter of length of the belt conveyor
- C_1 = Coefficient of friction between product and carrying side **
- C_2 = Coefficient of friction between carrying side and slider bed **
- C_3 = Coefficient of friction between return side and product **
- C_4 = Coefficient of friction between return side and slider bed **
- L in m = Center-to-center length
- H in m = Height difference in conveyor
- F_0 to F_3 in N = Belt pull components for operating conditions shown
- g in m/s^2 = 9.81

* The value F_2 is negative with declined conveyors. However, to prevent over-run acceleration due to gravity, F_2 should be positively calculated as for inclined conveyors.

** Information about friction factors page 111.

Coefficient of friction

| Belt material | Slider bed material C ₂ , C ₄ | | Product material C ₁ , C ₃ | | |
|------------------------|---|-------|--|----------------------|---------------|
| | PE | Steel | Steel | Glass, Technopolymer | Technopolymer |
| PE | 0.30 | 0.15 | 0.13 | 0.09 | 0.08 |
| PP | 0.15 | 0.26 | 0.32 | 0.19 | 0.17 |
| POM | 0.10 | 0.20 | 0.20 | 0.15 | 0.15 |
| PVC/PU | | 0.30 | 0.30 | | 0.30 |
| Polyamide or polyester | | 0.18 | 0.18 | | 0.17 |
| Rubber | 0.40 | 0.40 | 0.40 | | 0.40 |

Belt tension

The following must be observed when calculating the belt tension:

- Length and width of conveyor belt
- Belt type
- Check the belt tension required to transport the load
- Check the belt elongation necessary for the installation. Depending on the load, the belt elongation for the assembly should be between 0.2 – 0.5 % of the belt length.
- The values for the belt tension and elongation are available from the belt manufacturer.
- Ensure that the required belt tension does not exceed the maximum belt tension (TE) of the drum motor.

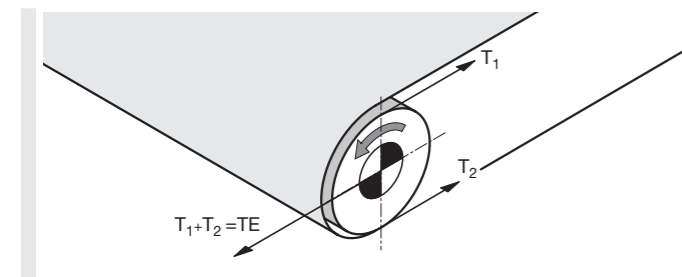

The required belt tension T1 (top side) and T2 (bottom side) can be calculated in accordance with DIN 22101 or the CEMA standard. Based on the information from the belt manufacturer, the actual belt tension can be roughly determined by a measurement of the belt elongation during tensioning.

The maximum allowable belt tension (TE) of each drum motor is specified in the drum motor tables in this catalog. Belt type, belt thickness and drum motor diameter must match the information from the belt manufacturer. If the diameter of the drum motor is too small, damage to the belt can result.

If the belt tension is too strong, it can damage the shaft bearings and/or other internal components of the drum motor and shorten the service life of the product.

Belt elongation

The belt tension is created by the force of the belt when it is stretched in longitudinal direction. To prevent damage to the drum motor, it is absolutely necessary to measure the belt elongation and to determine the static belt tensioning force. The calculated belt tension must be equal to or lower than the values specified in the drum motor tables in this catalog.

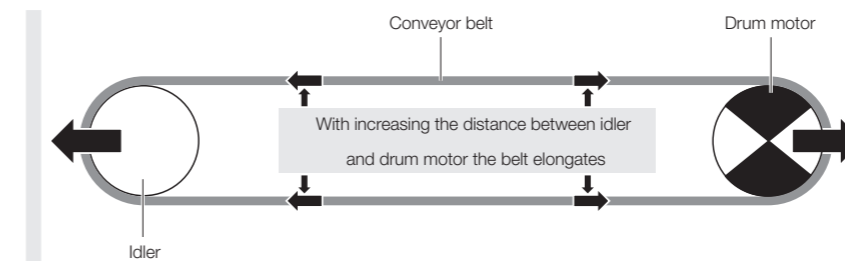

Fig.: Belt elongation

Measuring the belt elongation

The belt elongation can very easily be determined using a measuring tape. Mark the not-tensioned belt on two points in the belt center, where the outer diameter of the drum motor and idler pulley is the biggest due to the crowning. Measure the distance between the two marks parallel to the belt edge (Be0). The longer the distance between the two marks, the more precise the measurement of elongation will be. Now start to tension the belt and adjust it. Once the belt is adjusted and tensioned measure the distance between the two marks again (Be). The belt elongation increases the distance.

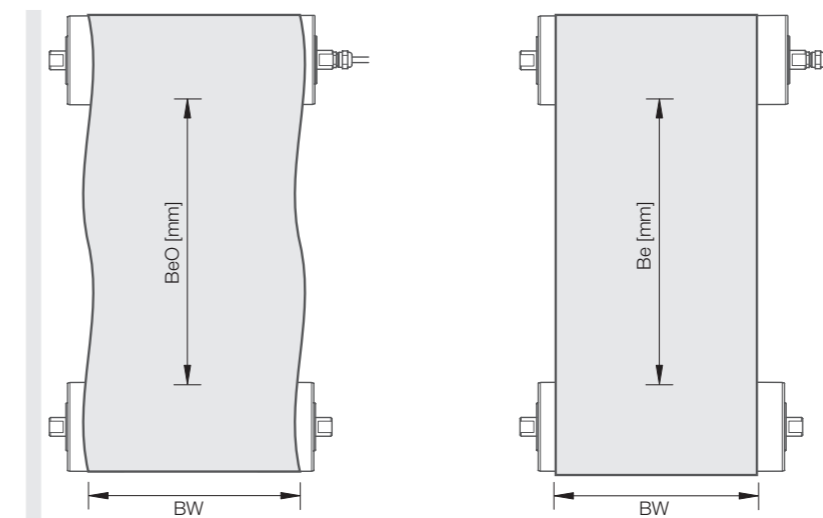

Fig.: Measuring the belt elongation

Belt elongation calculation

With the belt elongation measurement you can calculate the belt elongation in %.

$$B_{e\%} = \frac{B_e \cdot 100\%}{B_{e0}} - 100$$

Fig.: Formula for calculating the belt elongation in %

For the calculation of belt elongation, the following values are needed:

- Belt width in mm (BW)
- Static force per mm belt width with 1 % elongation in N/mm (k1 %). This value is usually given in the belt data sheet or can be requested from the belt supplier.

$$TE_{[static]} = BW \cdot k1\% \cdot B_{e\%} \cdot 2$$

Fig.: Formula for calculating the static belt tensioning force in N

Load and loading method

- Consider the method of loading, such as a feed conveyor, hopper loading or shock loading, and adjust the required belt pull and belt tension accordingly
- Consider the type and length of the load with regard to specific point loads and ensure that the weight of the point load (in Newtons) never exceeds the maximum belt tension (TE) of the drum motor.

Drum motor diameter

- Choose the drum motor with the smallest diameter, but with due consideration of all application parameters and ambient conditions
- Check the minimum flexing diameter allowed for the belt and choose the drum motor diameter accordingly

All belts have a safe minimum diameter for normal or back flexing when used with drum motors or idler pulleys. Always refer to the belt manufacturer's specification for this information and choose the drum motor diameter accordingly, otherwise serious damage to the belt or drum motor may result. If the drum motor diameter is too small, insufficient torque will be transmitted to the belt and belt slip or "jumping" may occur.

To illustrate: The belt shown below has cross cleats and side frames and requires a larger diameter of drum motor than would be required for a plain flat belt.

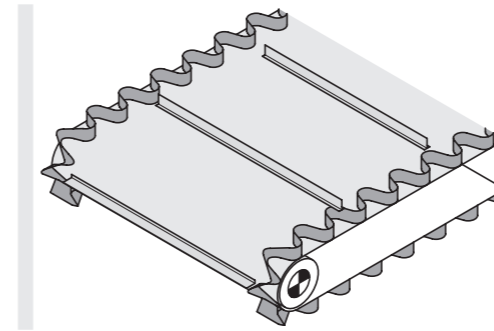

Single phase asynchronous motors

Single phase AC motors are typically used when 3-phase voltage is not available.

Principle

Single phase AC motors have a main winding and an auxiliary winding to create a rotating field. The phase shift between the main and auxiliary phase is created by a permanently connected running capacitor.

Starting torque/starting capacitors

The starting torque can be very limited because of the imperfect rotating field:

- The starting torque of a 3-phase AC motor is typically 120 – 410 % of rated torque
- The starting torque of a 1-phase AC motor is typically 65 – 115 % of rated torque

Some 1-phase AC motors – especially in the higher power range – need an additional starting capacitor to reach a starting torque of 150 – 200 % of the rated torque. This starting capacitor should be the same size as the running capacitor and has to be switched parallel to it. This should be done ideally via a current-dependent switch relay during the start-up sequence of the motor. When the right torque/current has been reached, the starting capacitor is switched off by the relay. The capacity value of the running capacitor is always stated on the motor type label.

Noise

1-phase motors generally have a higher noise level at zero-load operation compared to 3-phase motors, because of the difference in the rotating field. Typically there is an erratic noise that increases steadily. This does not affect the operation of the drum motor and will normally disappear when belt tension is applied or the drum motor is run under load. Claims cannot be accepted due to this noise effect.

Capacitors and relays

All capacitors must be ordered separately for single phase drum motors. A suitable current-dependent relay to convert the starting capacitor to a running capacitor can be supplied if needed. For more information, please contact your Interroll customer consultant. The correct installation of the starting capacitor is shown in the wiring diagram supplied with the drum motor.

Interroll strongly recommends the use of 3-phase motors, since they are more efficient and save energy. Improved efficiency can be achieved by using a 3-phase motor with a frequency inverter. If a single phase supply is the only option, consider using a 3-phase motor together with a frequency inverter that converts the single phase input voltage into a 3-phase output voltage.

| Standard Interroll capacitors | Article number |
|-------------------------------|----------------|
| 3 μ F | 1100692 |
| 4 μ F | 1000477 |
| 6 μ F | 1100821 |
| 8 μ F | 1100724 |

Note: Capacitors can have different service lives. Use only B rated capacitors.

Final design steps

Before deciding on the final design, additional factors, such as the motor's switching frequency, still must be taken into account. When using an asynchronous drum motor for stop/starts of more than one per minute, a frequency inverter with a ramp time ≥ 0.5 s should be considered. Alternatively, use a synchronous drum motor and frequency inverter. Choose the drum motor version with the required belt pull, belt tension, diameter and speed for your application. If you cannot find the required speed in the drum motor tables, use a frequency inverter and choose the drum motor version with the closest speed or contact Interroll. The Belt Drive Matchmaker at www.interroll.com provides support in the selection of the correct drum motor.

Protection rate

Interroll drum motors are provided with IP69k protection as standard.

| Protection against solid bodies | | Protection of internal equipment against harmful ingress of water | |
|---------------------------------|----------------|---|---|
| IP, first number | Definition | IP, second number | Definition |
| 5 | Dust-protected | 4 | Protected against spray water |
| 6 | Dust-tight | 5 | Protected against water jets (P1 nozzle 6.3 mm, water delivery rate 12.5 l/min ±5 %) |
| | | 6 | Protected against water jets similar to marine swells (P2 nozzle 12.5 mm, water delivery rate 100 l/min ±5 %) |
| | | 7 | Ingress of water in quantities causing harmful effects shall not be possible when the enclosure is temporarily immersed in 1 m water under standardized conditions of pressure and time |
| | | 9k | Protected against the effects of high-pressure liquids: <ul style="list-style-type: none"> • Test with fan nozzle • Test unit on turntable (5 revolutions/minute) • Water delivery rate 14 – 16 l/min • Water pressure about 8,000 to 10,000 kPa at 80 ± 5 °C with a duration of 30 s per position • Water aimed at the housing with increased pressure from any direction must not have any damaging effect |

Lagging

NBR

This type of synthetic rubber has good wear characteristics, excellent resistance to oil, fuel, and other chemicals. On top of that, it is also easy to clean. Its resilience makes NBR the perfect material for the rubber lagging of drum motors. It can be used in most material handling applications. NBR withstands temperatures from –40 to +120 °C, nitrile rubber is generally resistant to aliphatic hydrocarbons but, like natural rubber, can be attacked by ozone, aromatic hydrocarbons, ketones, esters and aldehydes. White NBR is accepted for the food processing industry and is offered with FDA and EC1935/2004 approval.

PU

PU represents any polymer consisting of a chain of organic units joined by urethane (carbonate) links. It is tear-resistant and is superior to rubber. Polyurethane has outstanding resistance to oxygen, ozone, sunlight and general weather conditions. Most PU formulations offer an extremely long lifespan, good resistance to heat and cold at temperatures of between –35 and +80 °C and is offered with EC 1935/2004 and FDA approval.

Note: Minimum PU thickness 4 mm, maximum shell length (SL) 1,200 mm.

Hot vulcanization

Hot vulcanized NBR rubber lagging can be used to increase friction between the drum motor and conveyor belt for high torque applications and to reduce belt slip. Alternatively, it can be profiled to drive modular belts and other special applications. Due to the high temperature of the process, the lagging must be applied to the shell before the drum motors are assembled. The result is a very strong bonded rubber, suitable for high torque applications and completely sealed to the shell. This method guarantees a long service life and is recommended for hygienic applications.

NBR profiled lagging is not recommended for use with solid homogeneous belts due to the high friction that can cause the belt to jump.

Cold vulcanization

Cold vulcanized NBR rubber lagging is used to increase the friction between the drum shell and belt in order to reduce belt slip. The cold process requires a special adhesive (cement) to glue the lagging onto the drum shell. Cold vulcanized white NBR is approved by the FDA. The lagging follows the original shape of the drum shell (crowned or cylindrical) and is not machined afterwards. However, the process can be applied quickly to finished assembled drum motors and therefore is a quick and easy solution.

Certifications

Interroll Drum Motors can be offered certified and approved according to UL 1004 for the North American market and cUL for the Canadian market.

Interroll Drum Motors for use in the food processing industry are EHEDG-compliant. The materials meet the requirements of the FDA, EC 1935/2004 and Ecolab. Cleaning specialist Ecolab has certified a 5-year minimum lifetime of materials used for Interroll Drum Motors when exposed to typical cleaning and disinfecting procedures using Ecolab's Topax range of products: P3-topax 19, P3-topax 686, P3-topax 56 and P3-topactive DES.



The Interroll Competence Center in Baal (near Düsseldorf) concentrates on drum motors that are employed as drive solutions in belt conveyors in food processing and other systems of internal logistics as well as various branches of industry. In this product sector, the company is responsible within the global Interroll Group for all technical concerns ranging from development and application engineering to production and support for local Interroll companies. The production area also includes the Coating Center for rubber-coated drum motors, which are intended for the hygienic production lines of the food industry.

Visit www.interroll.com to find your local contact person.

Interroll Trommelmotoren GmbH
Opelstr. 3 | 41836 Hückelhoven/Baal |
Germany Tel.: +49 (0)2433 44610

LEGAL NOTICES

Contents

We strive for the information presented to be correct, up to date and complete. We have carefully worked out the contents of this document. Nevertheless, errors and changes are expressly subject to change.

Copyright / intellectual property right

Texts, images, graphics and the like as well as their arrangement are protected by copyright and other protection laws. Reproduction, modification, transfer or publication of any part or the entire content of the document in any form is prohibited. This document is intended exclusively for information purposes and for intended use and does not authorize replicating the respective products. All identification symbols used in this document (protected trademarks, such as logos and commercial designations) are the property of Interroll AG or their respective owners and may not be used, copied or disseminated without prior written permission.

About Interroll

The Interroll Group is a globally leading supplier of high-quality key products and services for internal logistics. The company supplies roughly 23,000 customers (system integrators and plant manufacturers) throughout the world with a broad product range in the four product groups "Rollers" (conveyor rollers), "Drives" (motors and drives for conveyor systems), "Conveyors & Sorters" as well as "Pallet & Carton Flow" (flow storage systems). Core industries are courier, express and postal services, airports, food processing as well as distribution and other industries. With its headquarters in Sant'Antonino, Switzerland, Interroll features a worldwide network of thirty-two companies with roughly two thousand employees. The company was founded in 1959 and is listed on the SIX Swiss Exchange since 1997 and represented in the SPI Index.

interroll.com

INSPIRED BY
EFFICIENCY