

# KEY PRODUCTS

## SPIRAL LIFT



24V

48V

400V

### Product description

The Interroll Spiral Lift transports boxes, containers and goods in all shapes and sizes for a variety of industries. It is the best choice for continuous vertical transport with high throughput. The Spiral Lift is available in many configurations, is extremely quiet during operation and features a small footprint, which allows for an optimal utilization of space. The overlapping slats offer additional safety for the operator. The proven construction with rolling removal ensures less friction, which can lead to significant savings in energy. Thanks to its self-tensioning chain drive, the new Spiral Lift is extremely low in maintenance. Access to the chain mechanism is very easy so that the downtime can be reduced to a minimum.

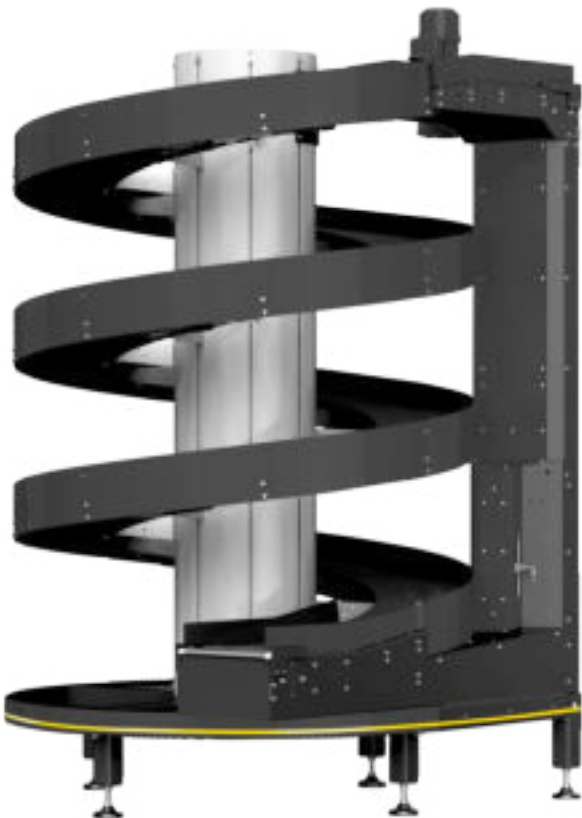

## Technical data

General technical data	
Speed	0.17 to 1 m/s
Max. load capacity	Up to 100 kg/m depending on the model 400 + 600 mm = max. 50 kg 760 + 900 mm = max. 100 kg
Drive	
Motor type	Gear motor
Rated voltage	400 V
Ambient temperature	-15 to +50 °C

## Dimensions

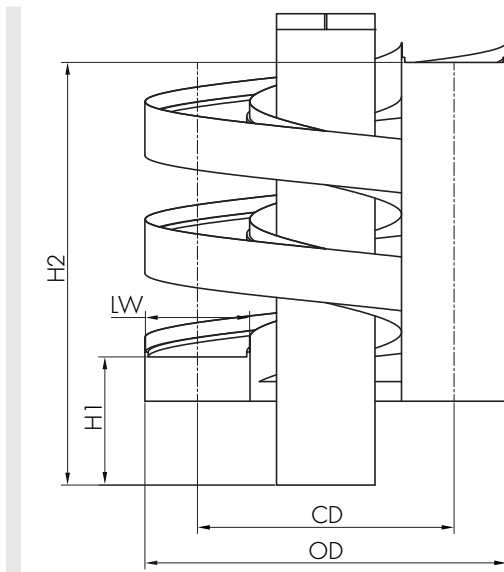

LW	Clear width	
H1	Height 1	Min. 367.5 mm (narrow design) Min. 450 mm (wide design)
H2	Height 2	Depending on type*
CD	Center diameter	Depending on plate width*
OD	Outside diameter	

\*See table below

# KEY PRODUCTS

## SPIRAL LIFT



24V

48V

400V

Plate width	Center diameter	Outside diameter	Max. H2 declining*	Max. H2 inclining*	Comment
400 mm for LW = 420 mm	1500 mm	2000 mm	H1 + 13357 mm	H1 + 10275 mm	
600 mm for LW = 620 mm	1700 mm	2400 mm	H1 + 15138 mm	H1 + 11645 mm	
760 mm for LW = 840 mm	2200 mm	3000 mm	H1 + 19590 mm	H1 + 15070 mm	For firm products
900 mm for LW = 840 mm	3000 mm	4000 mm	H1 + 26714 mm	H1 + 20549 mm	For soft products

\*Max. 13 windings, \*\*max. 10 windings

# KEY PRODUCTS SPIRAL LIFT



Roller conveyors

Belt conveyors

Key products

Accessories