

ROLLERS SERIES 3500 LIGHT

Fixed drive conveyor roller



ROLLERS SERIES 3500 LIGHT

Fixed drive conveyor roller



Application area

Driven unit handling conveying, transport of cardboards or containers with small dimensions. Suitable in the packaging industry, in assembly machines or for implementing machine chains.

Flexible design

The product is available in numerous chain drive versions. This allows implementing wrapping and tangential chain drives.

High-quality bearing

Sealed precision ball bearings of type 689 2Z are used.

Lateral loading

The tube ends are rounded, thereby allowing materials to be easily moved on from the side. Axial forces are removed through ball bearings and seals.

Small roller pitches

Small roller pitches can be implemented by using rollers with a diameter of 30 mm.



Technical data

General technical data	
Platform	1700
Max. load capacity	150 N
Max. conveyor speed	0.5 m/s
Temperature range	-5 to +40 °C
Material	
Tube	Zinc-plated steel, stainless steel
Shaft	Uncoated steel, zinc-plated steel, stainless steel
Bearing housing	Polyamide, RAL9005 (jet black)
Drive head	Uncoated steel (the sprocket heads including tube are zinc-plated after welding them on)
Seal	Polyamide on drive side each in RAL1021 (rape yellow)
Bearing version	Precision steel ball bearing 689 2Z, greased

Design versions

Tube sleeves	PVC sleeve (page 31)
Anti-static version	($10^6 \Omega$) Standard design for rollers with grooves or tube sleeves
Shafts	The following are available in addition to the variants listed in the load capacity tables: <ul style="list-style-type: none"> • With variable length • Different design of both shaft ends

ROLLERS

SERIES 3500 LIGHT

Fixed drive conveyor roller



ROLLERS

SERIES 3500 LIGHT

Fixed drive conveyor roller

Load capacities of series 3500 light

The load capacity table refers to a temperature range of +5 to +40 °C.
Valid for the following shaft designs: female thread or male thread.

Bearing: 689 2Z.

Tube material	Ø Tube/thickness [mm]	Drive element	Ø Shaft [mm]	Maximum static load [N] for installation length [mm]		
				200	400	600
Steel	30 x 1.2	Welded steel sprocket head 3/8", T12	8	150	150	150
		Welded steel double sprocket head 3/8", T12	8	150	150	150

T = Number of teeth

Dimensions

A sufficient axial play is already taken into account, so that the actual lane width between side profiles is required. The dimensions of the conveyor roller depend on the shaft version and the drive element.
Ordering dimensions for tube sleeves, e.g. PVC sleeves, see page 31.

- RL = Reference length/ordering length
- EL = Installation length, inside diameter between side profiles
- AGL = Total length of shaft
- U = Usable tube length: Length without bearing housing and for flanged metal tube without length of flanging

Ø Tube [mm]	Tube material	Ø Shaft [mm]	Drive element	EL [mm]	AGL [mm]	U [mm]
30 x 1.2	Steel	8	Welded steel sprocket head 3/8", T12	RL + 28	RL + 28	RL - 21
			Welded steel double sprocket head 3/8", T12	RL + 48	RL + 48	

T = Number of teeth

3/8" steel sprocket head with 12 teeth

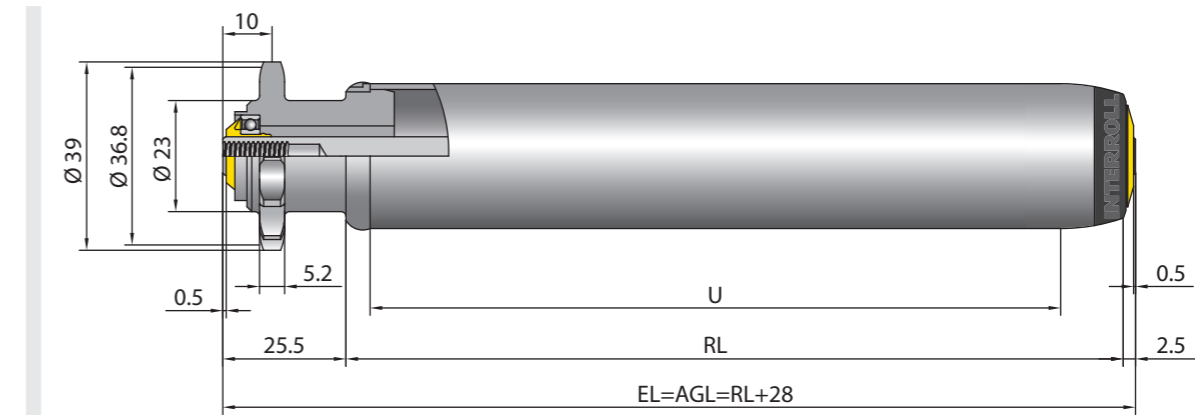

3/8" steel double sprocket head with 12 teeth

