

# KEY PRODUCTS

## BLADE STOP RM 8812



24V

48V

400V



### Product description

The Interroll blade stop is an electrically operated stop that is raised between the roller pitches in order to stop or accumulate material. Stops are often used in conjunction with conveyor components, such as transfers and pushers, to align products or coordinate processes.

### Scope of delivery

- Module is fully assembled, incl. sensor system and control card

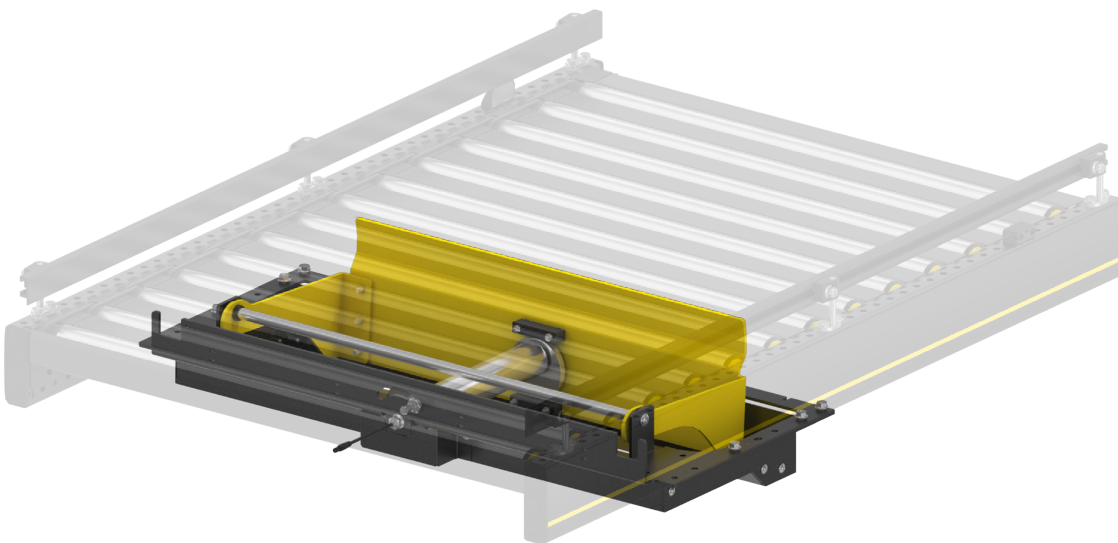

### Technical data

General technical data	
Maximum accumulation pressure	100 N
Ambient temperature	+5 to +40 °C
Drive	
Rated voltage	24/48 V

### Dimensions

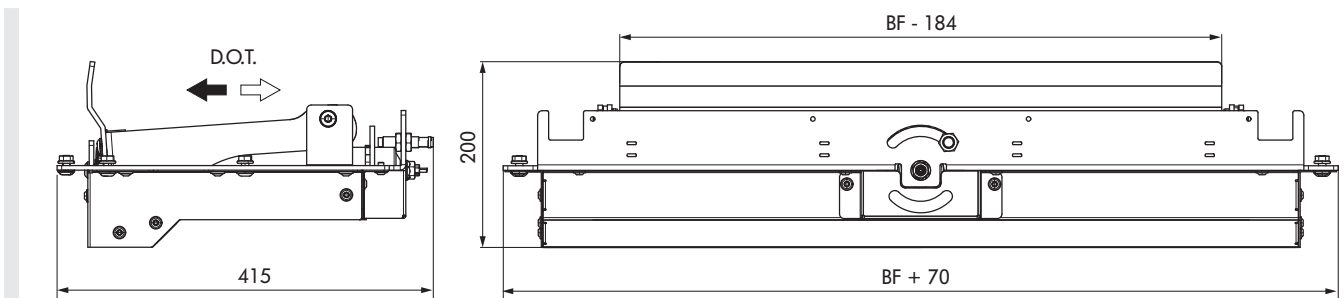

BF	Rated width	420, 620, 840 mm (others on request)
P	Min. roller pitch	90 mm
$\Delta H$	Stroke	25 mm (5 mm below top edge of roller up to 20 mm above top of roller)