

ACCESSORIES

FREQUENCY INVERTER FC 1000

24V

400V

The Interroll FC 1000 is a state-of-the-art decentral frequency inverter and can be used, among other things, for controlling Interroll drum motors in logistics applications, food processing, beverage industry and packaging applications.

It is suitable for synchronous and asynchronous motors and commands the sensorless control as well as operation with encoder feedback for positioning tasks.

The housing consists of aluminum; a version with special surface finishing is available for the food and beverage industry.

The frequency inverter is available in two installation versions: on the side frame of a conveyor or installed directly on the shaft of a drum motor.

Thanks to the exclusive use of plug connections, cabling according to the daisy chain principle, and the integrated Interroll motor database, the installation and startup is quick and simple. As a rule, the frequency inverter never has to be opened.

It features digital inputs and outputs, status LEDs, and an encoder interface. The FC 1000 is available in two sizes, and the design in size 2 is capable of controlling electromagnetic brakes without additional hardware.

The fieldbus protocols Profinet, Ethernet/IP, and EtherCAT are available for communication.



Technical data

General technical data			
Output frequency	0 – 400 Hz		
Pulse frequency	3 – 16 kHz, factory setting = 6 kHz		
Typical overload capacity	150 % tor 60 s, 200 % tor 3.5 s		
Efficiency	>95 %, depending on size		
Operating / ambient temperature	–30 to +40 °C (S1 - 100 % ED)		
Protection rate	IP55 or IP66 (nsd tUpH)		
Protective measures against	Overtemperature of the frequency inverter, overvoltage and undervoltage, short circuit, ground fault, overload		
Motor temperature monitoring	I ² t motor, PTC / bi-metal switch		
Control	Sensorless current vector control (ISD), linear V/f characteristics, VFC open-loop, CFC open-loop, CFC closed-loop		
Interfaces	4 digital inputs, 2 digital outputs (size 2) Encoder interface, RS232/485 programming interface		
Encoder system	Incremental TTL encoder SSI absolute value encoder		
Brake control (size 2)	PWM, brake rated voltage 100 – 300 V DC		
PLC	Integrated PLC for smaller control tasks		
Electrical data			
Version	450	370	950
Size	1	2	2
Rated power	0.45 kW	0.37 kW	0.95 kW
Supply voltage	3 AC 400 V –20 %...480 V +10 %, 47 – 63 Hz		
Input current	1.7 A	1.2 A	2.6 A
Output current	1.5 A	1.1 A	2.7 A

ACCESSORIES

FREQUENCY INVERTER FC 1000

24V

400V

Dimensions

Installation on the side profile

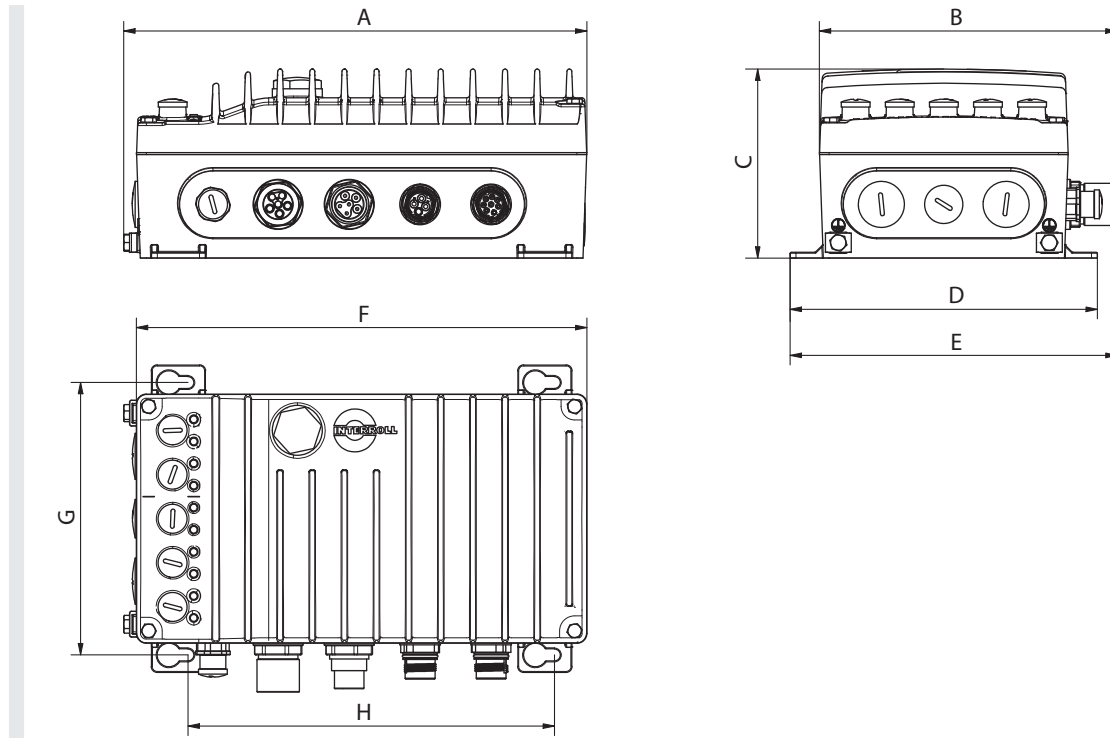

Fig.: FC 1000, wall-mounted, size 1 & 2

Device type	Size	Box dimensions								Weight [kg]
		A [mm]	B [mm]	C [mm]	D [mm]	S [mm]	F [mm]	G [mm]	H [mm]	
FC 1000	1	211	146	83	150	160	205	132	161	1.65
FC 1000	2	244	155	98	160	170	235	142	191	2.10

Installation on the motor

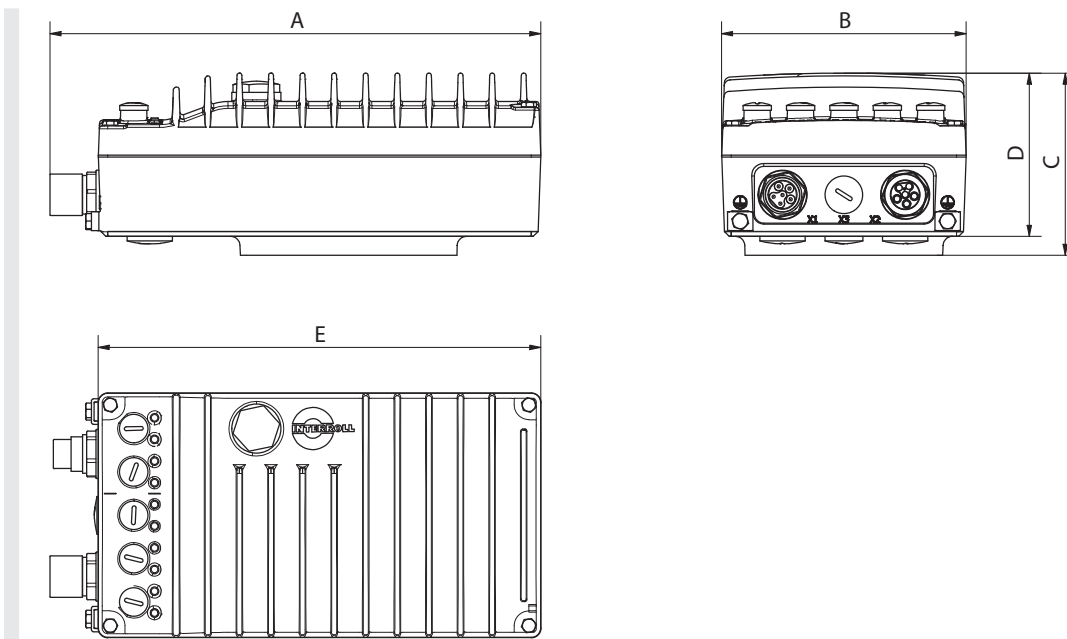

Fig.: FC 1000, motor-mounted, size 1 & 2

Device type	Size	Box dimensions					Weight [kg]
		A [mm]	B [mm]	C [mm]	D [mm]	S [mm]	
FC 1000	1	230	120	89	82	205	1.65
FC 1000	2	260	13	97	87	235	2.10

Accessories

Designation	Article number
Power cable 1.5 m	1129475
Power cable 3 m	1129476
Power cable 5 m	1129477
Power cable 10 m	1129478
Daisy chain cable 1.5 m	1129479
Daisy chain cable 3 m	1129480
Daisy chain cable 5 m	1129481
Daisy chain cable 10 m	1129482
Bluetooth adapter	1129483
USB adapter	1129484