

ROLLERDRIVE SERIES EC5000

Based on \varnothing 1.9", tapered, IP54, for 32 to 104 °F



24V

Application area

Drive for unit handling conveyor systems, such as transporting cardboard cartons, containers, platens or tires at normal ambient temperature. Suitable for roller/belt curves as well as constantly driven or zero pressure accumulation conveyor technology.

48V

20W

35W

50W

AI

BI

Compact design

The drive integrated in the tube allows a very compact design of the curve.

Very energy-efficient

The brushless drive features energy recovery when braking. The conveyor system can operate without pneumatics or conventional drives, which must be operated continually.

Robust design

In contrast to conventional designs, the tapered elements (gray and black) are secured against axial shifting. This safeguard prevents the tapered elements from shifting on the tube, similar to the matching conveyor rollers.

Flexible possible applications

RollerDrive is available in many variations, allowing it to be used in all types of different conveyor systems. For the user, this translates into a single interface instead of many. Depending on the application area, PolyVee or round belts can be used for the transmission of force. Nine gear ratios allow selecting the perfect pairing between speed and torque.

Low-noise

The use of decoupling elements achieves particularly low-noise running.

Maintenance-free and installation-friendly

The drive with internal commutation electronics does not require any maintenance. It features an overload protection that prevents damages due to overtemperature or blockage. It is connected securely without complex screw connection by using a motor cable with 5-pin snap-in plug.



ROLLERDRIVE SERIES EC5000

Based on \varnothing 1.9", tapered, IP54, for 32 to 104 °F

Technical data

Rated voltage	24 V	24 V	24 V	48 V	48 V	48 V
Power	20 W	35 W	50 W	20 W	35 W	50 W
Rated current	1.4 A	2.4 A	3.4 A	0.7 A	1.2 A	1.7 A
Starting current	3.0 A	5.5 A	7.5 A	1.5 A	2.8 A	3.8 A
Max. noise emission (installed)	55 dB(A), application-dependent					
Length of motor cable	19.6"					
Max. reference length	40"					
Ambient temperature in operation	32 to 104 °F					
Maximum load capacity per RollerDrive without drive head	104 lbs					
Max. load capacity per RollerDrive with drive head (PolyVee or round belt)	76 lbs					
Motor shaft	Stainless steel, 7/16" HEX, thread M12 x 1					
Anti-static version	No					
Tube wall thickness	0.065"					
Tube material	Zinc-plated steel, stainless steel					
Tapered cones	1.8° in black (not antistatic)					

Design versions

20 W

Gear ratio	Max. conveying speed [fpm]	Min. conveying speed [fpm]	Rated torque [in-lbs]	Acceleration torque [in-lbs]	Continuous blocking torque [in-lbs]
9:1	382	18	2.2	5.5	5.5
13:1	264	12	3.18	8.0	8.0
18:1	190	8	4.4	11.1	11.1
21:1	163	8	5.2	13.0	13.0
30:1	114	6	7.5	18.8	18.8
42:1	82	4	10.4	26.1	26.1
49:1	70	4	12.1	30.4	30.4
78:1	42	2	17.8	48.0	48.0
108:1	32	2	24.9	67.0	67.0

ROLLERDRIVE SERIES EC5000

Based on $\varnothing 1.9''$, tapered, IP54, for 32 to 104 °F



24V

35 W

48V

20W

35W

50W

AI

BI

Gear ratio	Max. conveying speed [fpm]	Min. conveying speed [fpm]	Rated torque [in-lbs]	Acceleration torque [in-lbs]	Continuous blocking torque [in-lbs]
9:1	382	18	3.89	9.8	9.8
13:1	264	12	5.6	14.1	14.1
18:1	190	8	7.8	19.6	19.6
21:1	163	8	9.2	22.9	22.9
30:1	114	6	13.1	33.1	33.1
42:1	82	4	18.3	45.8	45.8
49:1	70	4	21.4	53.4	53.4
78:1	42	2	31.4	84.4	84.4
108:1	32	2	43.8	115.0	115.0

50 W

Gear ratio	Max. conveying speed [fpm]	Min. conveying speed [fpm]	Rated torque [in-lbs]	Acceleration torque [in-lbs]	Continuous blocking torque [in-lbs]
9:1	382	18	5.5	13.98	13.98
13:1	264	12	8.0	20.2	20.2
18:1	190	8	11.2	28.0	28.0
21:1	163	8	13.0	32.7	32.7
30:1	114	6	18.8	47.2	47.2
42:1	82	4	26.1	65.4	65.4
49:1	70	4	30.5	76.3	76.3
78:1	42	2	44.8	115.0	115.0
108:1	32	2	62.5	115.0	115.0

Before the run-in, the values may differ up to $\pm 20\%$. After a run-in phase, the values vary only in the range of $\pm 10\%$ for 95 % of all RollerDrive used.

ROLLERDRIVE SERIES EC5000

Based on \varnothing 1.9", tapered, IP54, for 32 to 104 °F

Dimensions

The minimum reference length depends on the gear box variant, the grooves in the tube and the drive or the bearing assembly. A sufficient axial play is already taken into account, so that the actual clear width between side profiles is required. When using the tapered hexagon spring shaft, it must be ensured that the design of the axial play is not too high. If the RollerDrive selected is too short, the shaft may have play in the hexagon hole. A hexagon hole with a size of at least 0.44" is recommended. If the RollerDrive is installed obliquely, the fastening hole must be designed larger accordingly.

- RL = Reference length
- EL = Installation length
- U = Usable tube length: Length of tapered elements

Reference lengths with tapered elements

Conicity: 1.8°, color: black (not antistatic)		
Tapered rated length [inch]	Min. \varnothing [inch]	Max. \varnothing [inch]
11.85	2.30	3.05
13.62	2.19	3.05
15.61	2.07	3.05
15.80	2.30	3.30
17.57	2.19	3.30
19.56	2.07	3.30
19.75	2.30	3.56
21.53	2.19	3.56
23.51	2.07	3.56
23.70	2.30	3.81
25.48	2.19	3.81
27.46	2.07	3.81
27.66	2.30	4.06
29.43	2.19	4.06
31.41	2.07	4.06
31.61	2.30	4.32
33.38	2.19	4.32
35.36	2.07	4.32

ROLLERDRIVE SERIES EC5000

Based on $\varnothing 1.9''$, tapered, IP54, for 32 to 104 °F



24V

Hexagon spring shaft, without grooves

48V

20W

35W

50W

AI

BI

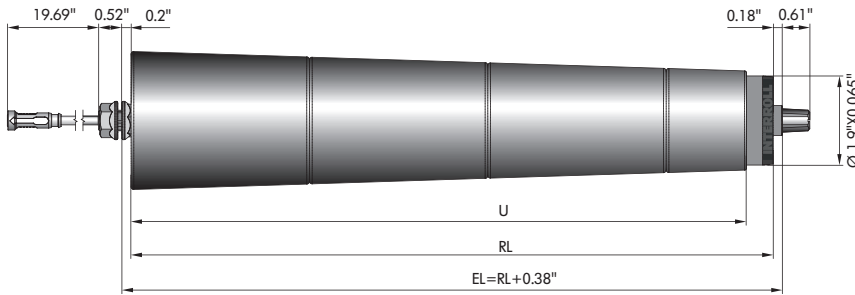

5/16"-18 or M8 female thread, with grooves

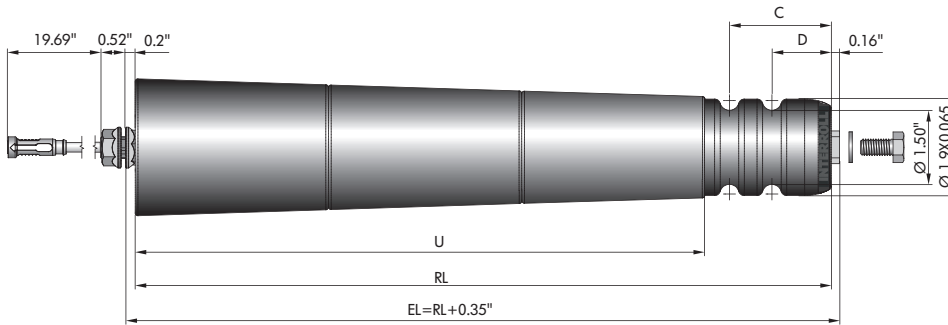

PolyVee drive head with M8 female thread

