

CONTROLS

DRIVECONTROL 20

For EC5000, 24 V

20 W, 35 W, with analog interface



24V

48V

20W

35W

50W

AI

BI

Application area

Control of RollerDrive EC5000 in applications without start-stop operation, e.g. in roller curves.

Mechanical engineering applications. Applications with PLC, but without fieldbus. Small applications with max. ten RollerDrive.

Product description

The DriveControl 20 is a simple control for the RollerDrive EC5000. It does not contain any logic (e.g. for zero-pressure accumulation conveying) and requires external signals.

DIP switches can be used to set the direction of rotation, a start and braking ramp and the speed in 15 increments. Digital inputs and outputs serve as interface to a higher-level control. Signals allow adjusting the direction of rotation and the speed in seven increments. The braking energy of the RollerDrive EC5000 is fed back into the DC supply system. The voltage fed back from the RollerDrive EC5000 is limited at 30 V by means of the integral brake chopper (voltage-dependently switched load resistance).

Functions

- Speed setting (DIP switches 15x, digital input 7x)
- Selection of direction of rotation (via DIP switches or digital input)
- Error signal output
- Status display with LEDs
- Voltage limitation via brake chopper



CONTROLS DRIVECONTROL 20

For EC5000, 24 V
20 W, 35 W, with analog interface

Technical data

Electrical data	
Rated voltage	24 V DC
Voltage range	19 to 26 V DC
Current consumption	DriveControl: approx. 0.5 A + current of RollerDrive EC5000*
Fuse	Present, non-replaceable
Protection rate	IP20
Ambient conditions	
Ambient temperature in operation	32 to 104 °F
Ambient temperature during transport and storage	-40 to 176 °F
Max. installation height above sea level	3280 ft (at higher altitudes, a reduction of performance values is possible)
Cable cross-sections	
Power supply	Fine-wired, 1.5 mm ² (AWG 16)
Inputs/outputs (I/O)	Fine-wired, 0.08 to 0.5 mm ² (AWG 28 to 20)

* The power of EC5000 depends on the application, e.g., conveying good weight, conveying speed, acceleration ramp, and on the EC5000 used (refer to the corresponding chapter).

Dimensions

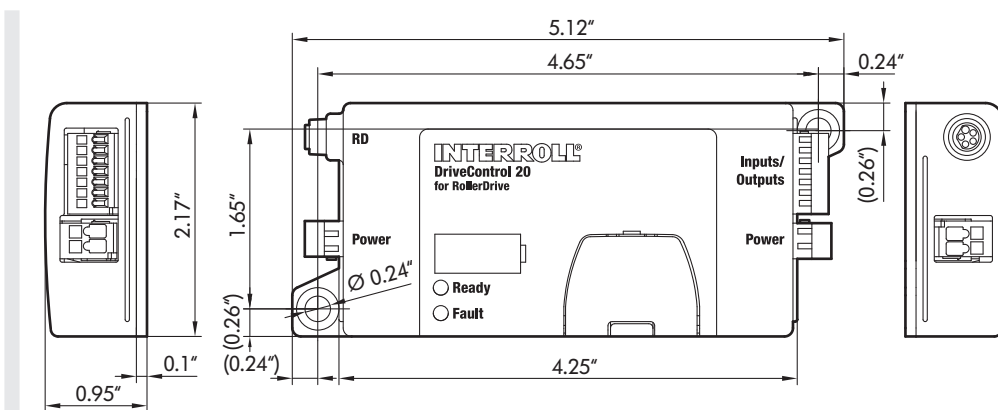

Accessories

- RollerDrive EC5000 extension cable, page 62
- Switching power supply HP5424, page 52

Ordering information

- Article number: S-1001415
- Scope of supply: 2 plugs for voltage supply, 1 plug for inputs and outputs, polymer tool for cabling