

# DM SERIES OPTIONS AND ACCESSORIES SPROCKETS

For drum motors and idler pulleys

## Sprockets



### Hygienic, quiet and long lifespan

The solid homogeneous polymer sprockets are suitable for applications in food processing with high hygienic requirements: Easy to clean and extremely resistant to oil, grease and chemicals. Furthermore, they ensure smooth running and provide a long lifespan of the belt due to its low abrasion. These sprockets are available for the most common positive drive solid homogeneous belts as well as for motors in applications with drive belts. Based on the specifications of the specific belt manufacturer, up to 44 teeth mesh with the profile.

**Note:** It is important to incorporate a calculation of belt pull and speed that is adjusted to the greater outer diameter of the drum motor. Please refer to the velocity factor (VF) in the table on page 135. Only one fixed sprocket per drum motor should be fitted to allow for belt expansion.

### Technical data

<b>Material</b>	Polyketon (PK) with stainless steel inlay
-----------------	---

# DM SERIES OPTIONS AND ACCESSORIES SPROCKETS

For drum motors and idler pulleys

## Versions

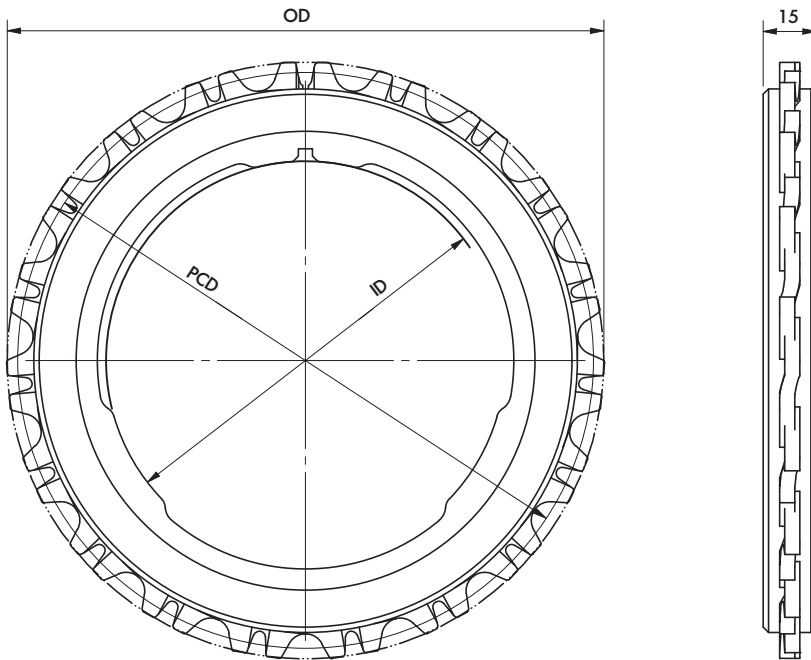

OD = Outer diameter in mm      PCD = Pitch diameter in mm  
ID = Inner diameter in mm

## Product selection

Drum motor	Belt manufacturer	Series	Article number	Belt drive	Z	ID [mm]	OD [mm]	PCD [mm]	VF
DM 0080	Intralox	2400	64100985	Floating	16	81.7	131.4	130	1.59
		2400	64101024	Fixed	16	81.7	131.4	130	1.59
		900	64100986	Floating	15	81.7	134.7	130.7	1.60
		900	64101025	Fixed	15	81.7	134.7	130.7	1.60
	Habasit	M25	64100987	Floating	16	81.7	131.9	130.8	1.60
		M25	64101026	Fixed	16	81.7	131.9	130.8	1.60
	Intralox	1000	64100988	Floating	24	81.7	121.7	115	1.41
		1000	64101027	Fixed	24	81.7	121.7	115	1.41
	Ammeraal Beltech/Uni- Chains	M-QNB	64100989	Floating	30	81.7	124.8	119.6	1.46
		M-QNB	64101028	Fixed	30	81.7	124.8	119.6	1.46
SNB-M2		64100990	Floating	16	81.7	134.4	129	1.58	
SNB-M2		64101029	Fixed	16	81.7	134.4	129	1.58	

# DM SERIES OPTIONS AND ACCESSORIES SPROCKETS

For drum motors and idler pulleys

Drum motor	Belt manufacturer	Series	Article number	Belt drive	Z	ID [mm]	OD [mm]	PCD [mm]	VF	
DM 0113	Intralox	2400	64100960	Floating	20	113	163.3	163.3	1.45	
		2400	64101030	Fixed	20	113	163.3	163.3	1.45	
		900	64100961	Floating	19	113	169	165	1.46	
		900	64101031	Fixed	19	113	169	165	1.46	
	Habasit	M25	64100975	Floating	20	113	165.2	163	1.44	
		M25	64101032	Fixed	20	113	165.2	163	1.44	
	Intralox	1000	64100976	Floating	32	113	161.1	154.3	1.37	
		1000	64101033	Fixed	32	113	161.1	154.3	1.37	
	Ammeraal Beltech/Uni-Chains	M-QNB	64100977	Floating	38	113	157.4	152.3	1.35	
		M-QNB	64101034	Fixed	38	113	157.4	152.3	1.35	
		SNB-M2	64100978	Floating	20	113	169.1	163.3	1.45	
		SNB-M2	64101035	Fixed	20	113	169.1	163.3	1.45	
	DM 0138	Intralox	2400	64100979	Floating	24	137	195.4	195.4	1.43
			2400	64101036	Fixed	24	137	195.4	195.4	1.43
900			64100980	Floating	22	137	195.6	191.6	1.40	
900			64101037	Fixed	22	137	195.6	191.6	1.40	
Habasit		M25	64100981	Floating	23	137	189.2	187.2	1.37	
		M25	64101038	Fixed	23	137	189.2	187.2	1.37	
Intralox		1000	64100982	Floating	40	137	188.3	181.7	1.33	
		1000	64101039	Fixed	40	137	188.3	181.7	1.33	
Ammeraal Beltech/Uni-Chains		M-QNB	64100983	Floating	44	137	182.4	177.1	1.29	
		M-QNB	64101040	Fixed	44	137	182.4	177.1	1.29	
		SNB-M2	64100984	Floating	23	137	192.7	187	1.36	
		SNB-M2	64101041	Fixed	23	137	192.7	187	1.36	

Z = Number of teeth  
 OD = Outer diameter in mm  
 PCD = Reference diameter in mm

VF = Velocity factor  
 ID = Inner diameter in mm