

Endless opportunities through Interroll's **proven technologies**



Convey



Sort



Store



Pick



The leading global supplier of products and solutions for material handling

Our comprehensive product portfolio meets the needs of
system integrators and OEMs all over the world.

THE INDUSTRIES WE FOCUS ON



AIRPORTS



COURIER,
EXPRESS &
PARCEL (CEP)



FOOD &
BEVERAGE



PHARMACEUTICAL



MANUFACTURING

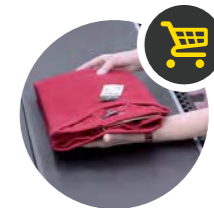

RETAIL
(INCL. FASHION)



SUPERMARKETS
& E-GROCERIES



TIRE & AUTOMOTIVE
(INCL. BATTERIES &
E-MOBILITY)



WAREHOUSING
& DISTRIBUTION
(E.G. DHL, K&N)

The Interroll Group

Established in 1959, Interroll has grown to become the world's leading supplier of key equipment for **material handling**.

Whether you're handling boxes, pallets, parcels, or soft goods, no other supplier has such a comprehensive range of solutions on offer.

This is why system integrators, OEMs and end users choose Interroll as a trusted partner for material handling installations, worldwide.

Interroll's global reach ensures quick delivery and superior after-sales service for customers, no matter where they are.



Our Global Network



36
SUBSIDIARIES &
PRODUCTION
SITES



CHF 527.1 M
TURNOVER



2,300
EMPLOYEES



Holding



Manufacturing
Unit











Sales
Unit





Mixed

Convey

-  **Rollers** p.08
-  **Accessories** p.09
-  **DC Platform** p.10
-  **Controls** p.11
-  **Drum Motors** p.12
-  **Modular Conveyor Platform MCP** p.14
-  **MCP PLAY** p.16
-  **High Performance Conveyor Platform HPP** p.18
-  **MCP CleanLine** p.19

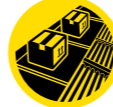

Sort

-  **Sorter Solution Portfolio** p.20
-  **Interroll Sortteq Modular Chainbelt Sorter MC-S** p.22

Pick

-  **Light Conveyor Platform LCP** p.24
-  **Carton Flow** p.26

Store

-  **Modular Pallet Conveyor Platform MPP** p.28
-  **Pallet Flow** p.30

Service

-  **Interroll Lifetime Service** p.32



Rollers

Interroll produces up to **60,000 different types of industrial quality ISO 9001** rollers every year and offers short lead times, regardless of the quantity ordered.



Wide range of rollers suitable for all industries

- Gravity or driven
- Straight or conical
- For packages or pallets
- In steel, stainless steel or PVC

Accessories

- Accessories for conveyors** and workstation equipment
- Ergonomic workstations** to reduce stress and injuries
- Gravity ramps** to reduce energy costs



BALL TRANSFERS

WHEEL TRACKS

OMNIDIRECTIONAL MODULE

POLYMER CONVEYOR WHEEL

CONVEY



DC Platform RollerDrive

The RollerDrive is a safe, **low-voltage powered roller for driving roller conveyors**. It is suitable for zero pressure accumulation (ZPA) applications. ZPA is a function, typical for Interroll roller conveyors, which allows the accumulation of boxes or cartons without contacting each other. In addition, ZPA saves significantly more energy than conventional methods of accumulating boxes or cartons.

- DIAMETER**
50 / 60 mm
- VOLTAGE**
24 / 48 V
- POWER**
20 / 35 / 50 W

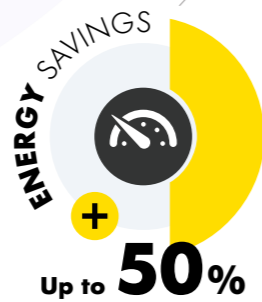

- Maintenance-free**
- Safe to install**
- Accurate positioning**
- Simple retrofitting** of existing installations
- Industry 4.0 ready**
- Up to IP66 rating**
- UL-certified**
- Analog- and bus-interface possible**

- Detailed diagnostics for predictive maintenance
- Quiet operation and minimal wear
- Compact design
- Quick and easy assembly

Controls

Complete and direct management of **various functions**

- **Motors and sensors**
- **Acceleration and deceleration ramps**
- **ZPA function**
- **Speed control**

Compatible with almost all PLCs
via EtherNet/IP, EtherCAT, and PROFINET

UL certified four-zone control solution
to control EC5000, transfer modules and High Performance Diverts

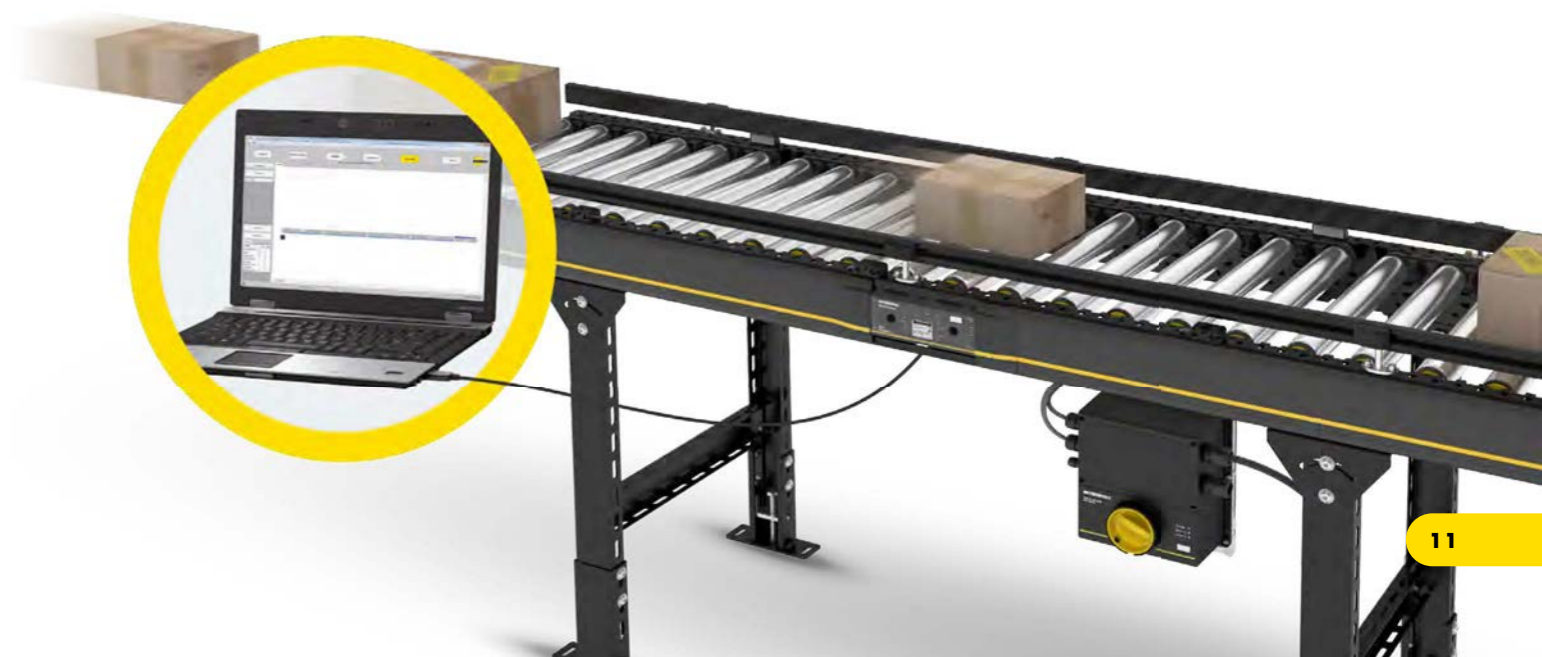

Drum Motors

The **Interroll Drum Motor Platform** allows you to create belt drive solutions compatible with the most common friction driven belts, Modular Plastic Belts (MPB), or TPU belts.

EHEDG design
and IP69K ratings

Easy
installation

Energy efficient:
Energy savings up to 50% compared with conventional systems

Quick & easy
assembly/disassembly, compact solution

Oil-free
versions available

Low maintenance
and extremely durable

Space saving
design

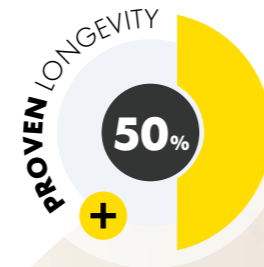

Synchronous or asynchronous versions

The most powerful and energy-efficient drive with high dynamics and high torque.

- Very high** stop/start rate
- Speed variation** | 1:15 in open loop
1:1000 with encoder feedback
- Encoder option:**
 - > Resolver
 - > Incremental
 - > Absolute encoder, single turn, Hiperface compatible with servo drives
- Durable** and robust
- Accurate** positioning
- Lagings and sprockets**
 - > PU lagings
 - > NBR lagings
 - > PK / stainless steel hybrid sprockets
- Speeds from** 0.03 to 2.72 m/s
- Fast deliveries** and service



- GLOBAL AVAILABILITY**
- COMPATIBLE WITH MOST MODULAR PLASTIC BELT (MPB)**
- HIGH TORQUE AND LOW NOISE**
- MODULAR CONSTRUCTION**
- ENERGY-EFFICIENT**
- STRONG DYNAMICS**

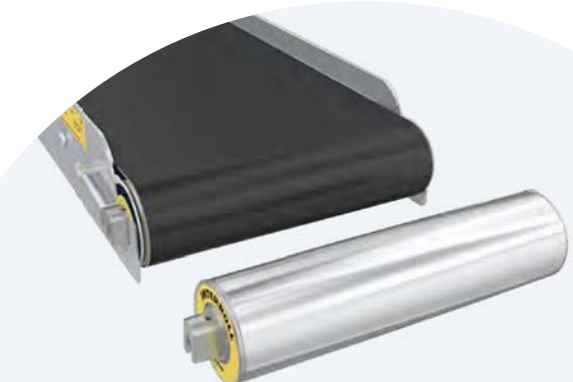

Light-duty and supermarket checkout
Versions available:

- > Checkout drives & soft-start controls
- > Cassette systems
- > Reverse vending machines
- > Lean, pre-assembled, light-duty industrial conveyors

Modular Conveyor Platform **MCP**

Smart, economical and flexible. Interroll's conveyor modules are the most versatile and durable systems available, assuring the highest availability and scalability for future growth.

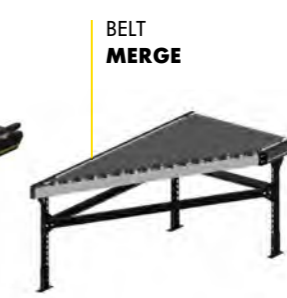
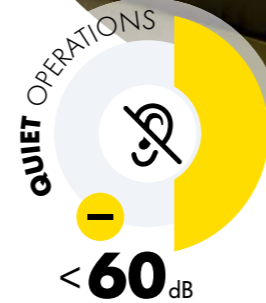

- 100% electric**
24V, 48V or 400V
- Deep freeze -30°C**
applications
- Simple retrofitting**
of existing installations
- Plug & play**
modules
- Up to **50kg/m**
- Speeds up to **2m/s**

- Flexible with angles of **30°/45°/60°/90°**
- Up to **75kg/m**
- Speeds up to **2,85 m/s**

- Up to **50kg/m**
- Speeds up to **2m/s**
- Quick and easy**
maintenance

MCP PLAY

Faster, easier, smarter:
The future of conveying starts today.

Interroll is pioneering the future of material handling with **MCP PLAY**, an advanced evolution of the industry-standard **Modular Conveyor Platform (MCP)**. Designed with cutting-edge intelligence, it enhances design, implementation, commissioning, and operational management for unmatched efficiency. Backed by multiple patents, **MCP PLAY** sets a new benchmark in innovation, empowering system integrators to accelerate quoting, reduce project timelines, and optimize workforce flexibility.

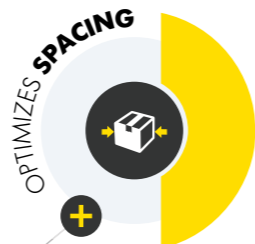

Faster commissioning and ramp-up for **quicker project delivery**

Simplified layout design with intuitive software tools

Reduced programming workload, **saving time and resources**

Eliminates the need for advanced programming expertise, giving you more **flexibility with personnel**

Seamless integration with minimal operational disruption

Improved energy efficiency for the end user



The seamless flow of goods, without interruptions or restarts, **reduces power consumption**, minimizes wear, and enhances sustainability. Streamlined processes from design to operations boost productivity and **enhance every workflow phase**, while the continuous flow of optimally spaced goods maximizes throughput.

MCPPLAY



+ MAIN PRODUCT FEATURES

High flexibility with "Adjust to Gap."

Optimizes spacing between items on the conveyor, ensuring smooth product flow, preventing collisions, and improving sorting accuracy.

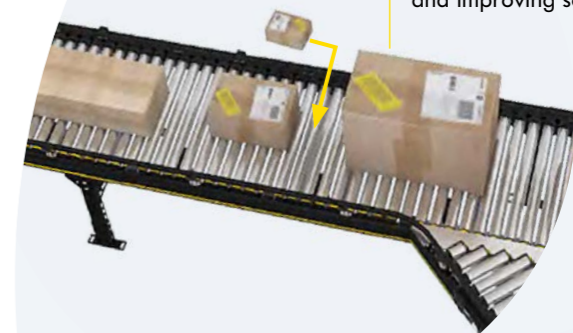

Continuous flow with "Flowing Merge."

This new continuous flow function for goods offered by MCP PLAY is a major advancement. The revolutionary feature delivers unprecedented speed, taking overall system efficiency to higher levels.

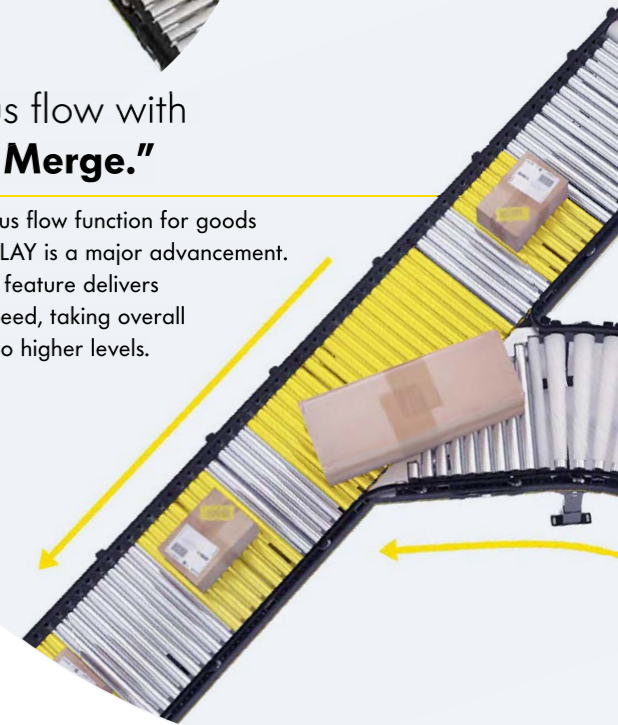



High Performance Conveyor Platform **HPP**

The benefits of a **flexible modular system of conveyor modules** are now available to system integrators and end users in the CEP industry.



A variety of modules for **specific needs:**

- **Inclined or descending conveyors**
- **Based on proven technologies**
- **Seamless material flow**

 **Low maintenance,**
optimal performance

 **Robust**
and reliable

 **High flow**

MULTIBELT SWITCH **MBS**

 High throughput:
> 10,000 pcs/hr

 **80 kg/meter** or
50 kg/item

 Up to
8 destinations





MCP CleanLine

This solution not only **ensures food safety** but also improves operational efficiency, sustainability, and worker safety. The CleanLine is designed for precise, efficient handling of packaged food products, offering zero pressure accumulation (ZPA) functionality to optimize energy use and reduce waste. CleanLine roller conveyors also feature a sealed design to prevent contamination and are highly water-efficient, reducing the risk of microbial build-up during cleaning.

Modular
stainless steel platform 

Easily interfaces
with existing applications 

Waterproof:
all components are at
least IPX5 certified 

Energy savings
up to **50%**
possible with ZPA 

Suitable for
dry to moist
packed food applications
from -5°C to +40°C 



Sorter Solution Portfolio

MCP WITH HIGH-PERFORMANCE DIVERT **HPD**

For diverting unit loads at different angles onto a lateral track.
Up to 3,600 items/hour



INTERROLL SORTTEQ MODULAR CHAINBELT SORTER **MC-S**

Smart, fast and modular parcel sorting for all kinds of items.
Up to 8,000 items/hour



MULTIBELT SWITCH **MBS**

Stable and reliable transport of all types of goods.
Up to 10,000 items/hour



SPLIT TRAY SORTER

Effective sortation for insensitive goods with large number of destinations.
Up to 21,600 items/hour



VERTICAL CROSSBELT SORTER



Linear sorter, space saving design, small footprint.
Up to 14,000 items/hour



HORIZONTAL CROSSBELT SORTER

Loop sorter, high number of destinations and basic mechanics.
Up to 20,000 items/hour



-  Throughput rates of **2,000 to 20,000** units per hour
-  Sorting of parcels **up to 50kg**
-  **Quiet operations** <67dB(a)



Flexible Sorting Across All Key Industries.

Interroll's sortation portfolio is designed for a wide range of industries with varying throughput needs. Our systems ensure reliable, high-speed sorting with minimal downtime. From sensitive goods in pharma to rugged packaging in CEP and food-grade modular options, our sorters can be configured to match your precise operational and regulatory requirements.

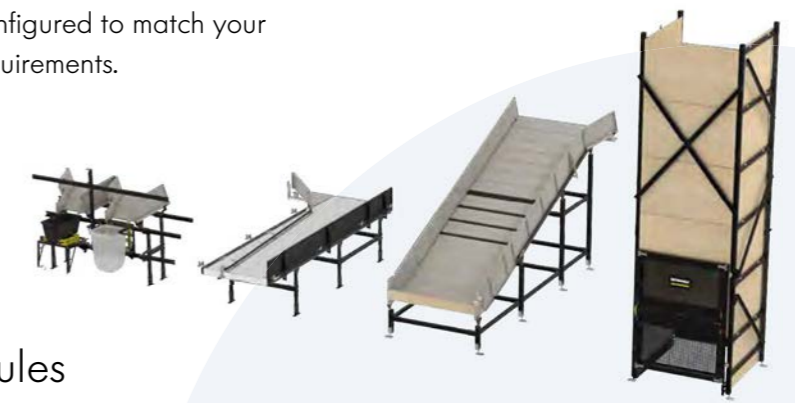

Infeed Modules

- Smooth and efficient
- Manual or automated
- Minimal impact on system throughput



Control Systems

- Intuitive architecture
- Easy integration
- Energy-efficient, consistent and accurate

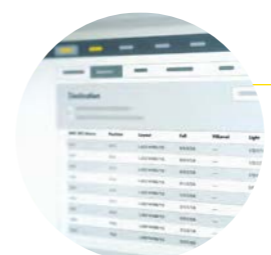

MODULAR DESTINATION PLATFORM **MDP**

A flexible and ready-to-use solution for discharge, the MDP accommodates a wide range of item types and weights. It features low noise operation, optimized spacing, and tailored chutes for every application. Easily expandable, the MDP ensures precise, reliable delivery to designated output lanes.



Interroll Sortteq Modular Chainbelt Sorter **MC-S**

Designed for space-efficient, medium-to-high throughput applications up to 8,000 items/hour, the Interroll Sortteq Modular Chainbelt Sorter MC-S offers reliable, gentle sortation all kinds of items.

The mechanical design is built for durability, requiring minimal maintenance and providing high accuracy while allowing for an efficient use of space. This makes it suitable for handling cartons, totes, polybags, envelopes, skiffy envelopes, and unshaped items in busy distribution environments.

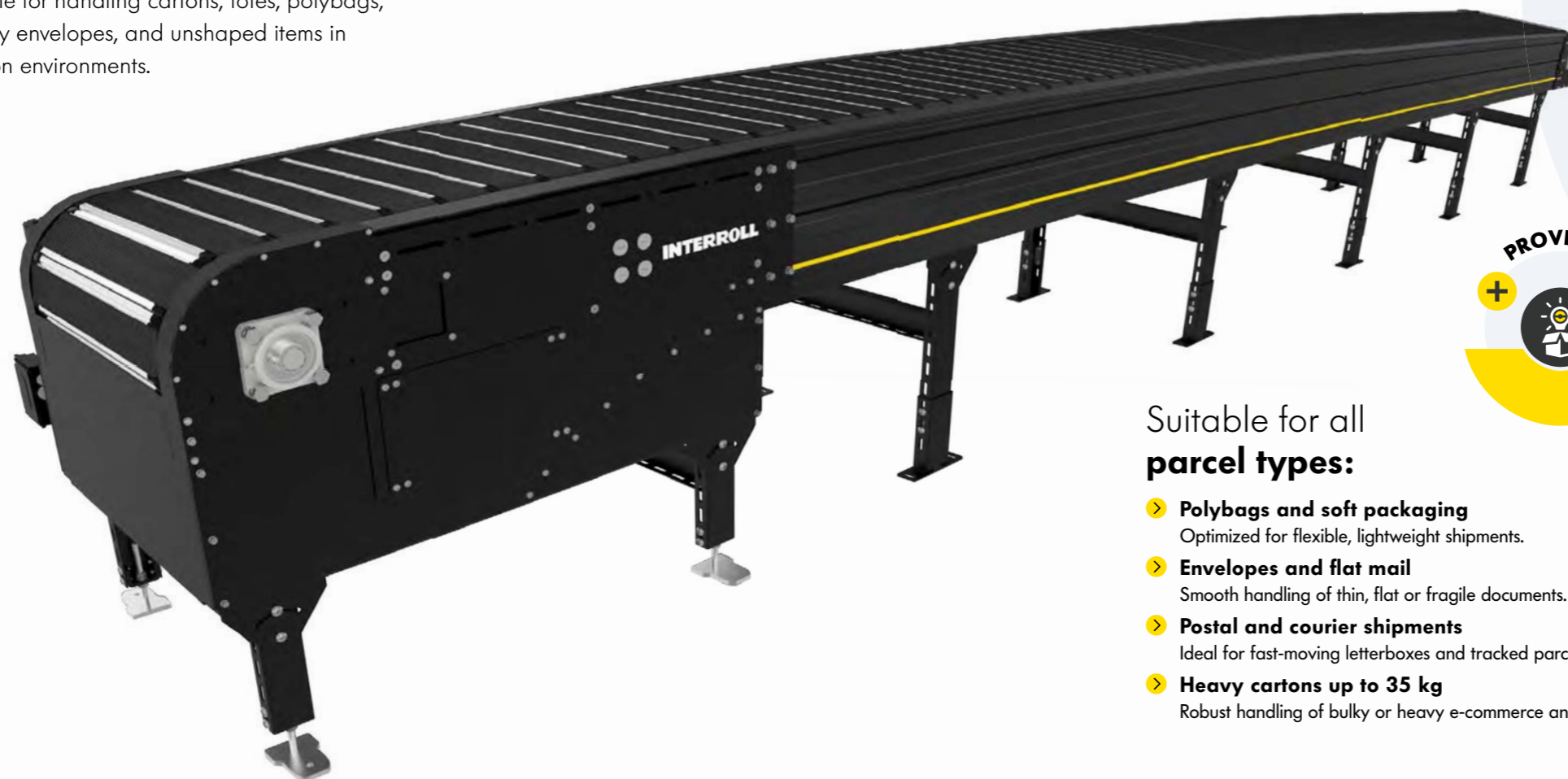

Proven mechanical design
guarantees high reliability



Minimal downtime
due to a maximum maintenance friendly design



Narrow belt pitch
with wide belts for process reliability for smallest item sortation





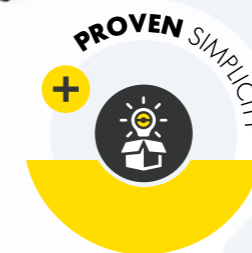

+ MAIN PRODUCT FEATURES

-  Throughput:
Up to 8,000 pcs/hr
-  **Up to 35 kg**
-  **Easy lock system**
Belt replacement with just two clips
-  **Modular design**
for maximum scalability
-  **Safety and compliance**
CE-certified closed deck
-  **Three-bus system**
High voltage, 24V low voltage, and communication
-  **Smart technology and control**
Intelligent switching with integrated sensors and friction-driven chain system without external motor ensures reliable performance



Suitable for all parcel types:

-  **Polybags and soft packaging**
Optimized for flexible, lightweight shipments.
-  **Envelopes and flat mail**
Smooth handling of thin, flat or fragile documents.
-  **Postal and courier shipments**
Ideal for fast-moving letterboxes and tracked parcels.
-  **Heavy cartons up to 35 kg**
Robust handling of bulky or heavy e-commerce and B2B orders.



PICK / CONVEY

QUIET OPERATIONS

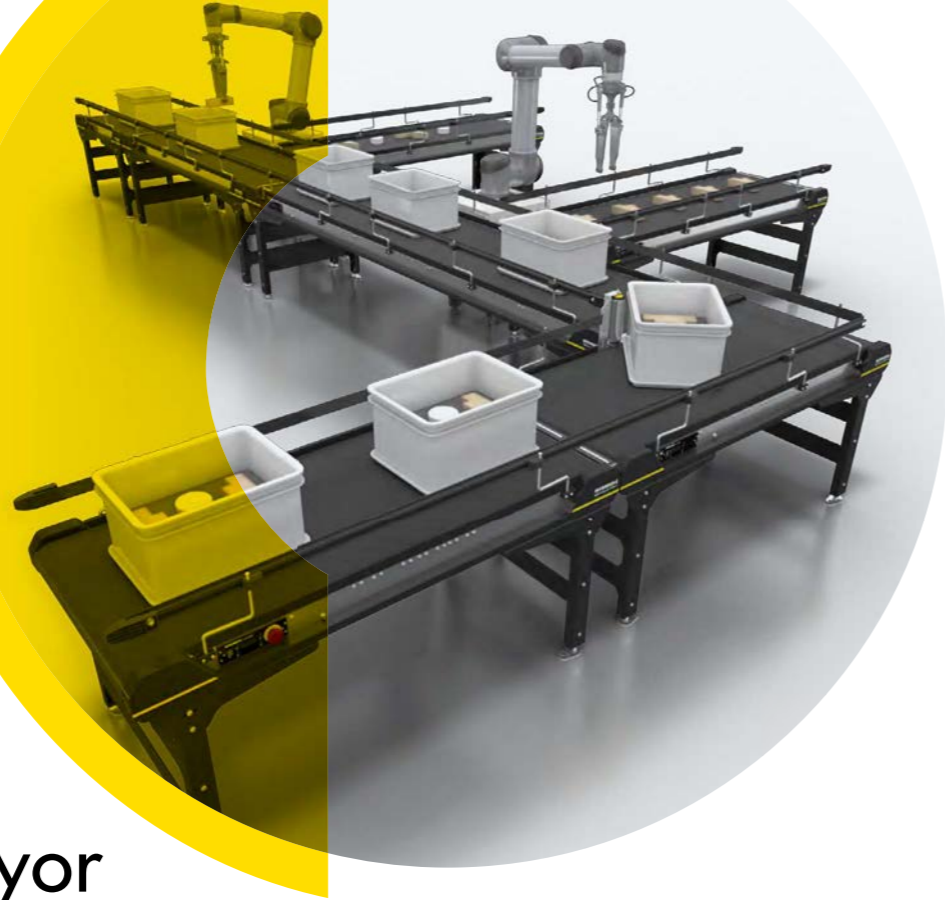
 < 60 dB



Light Conveyor Platform LCP

Ready to use conveyor. The Light Conveyor Platform (LCP) is Interroll's solution for production and manufacturing logistics, as well as in the field of assembly and automation. It is a modular platform based on a light and robust design that is easy to integrate.

-  **Designed** for manufacturing and assembly (DFMA)
-  **Short delivery times** thanks to "assemble to order" principle
-  **Ready to use solution** enables easy integration
-  **Easy maintenance** thanks to smart design
-  **ESD** suitable for electronic production environment

LCP CONVEYOR



LCP TRANSFER



LCP CONTROL



AMR TOP MODULE







AMR IR-MODULE



PROVEN SIMPLICITY

 +

-  **Maximum safety** for employees and incorrectly off-loaded goods
-  **UL components** to ensure ease of certification
-  **Simple interface** and seamless communication between the AMR and the Top Module
-  **Proven solution** Extensively tested with robot partners
-  **Scalable** modular platform solution

AMR TOP MODULE

Scalable solution. The LCP AMR Top Module is an expansion to the Light Conveyor Platform (LCP) which enables handling of lightweight goods on the Autonomous Mobile Robot (AMR). Unlike other top module manufacturers, Interroll offers a complete solution which is unique in the market.



Carton Flow Shelves for Cartons & Totes

-  **Ergonomic, maintenance-free,** fast, and easy to install
-  **No power required,** gravity solution
-  **High density storage** and pick rates



CARTON WHEEL FLOW

-  **Ergonomic** carton flow solution
-  **Ideal for order picking** of high turnover SKUs
-  **Proven, reliable solution** for flat bottom boxes and totes
-  **Compatible with all** racking and shelving types

VERSI FLOW

- Versatile solution** for multiple types of goods 
- Easy flowability** thanks to its large diameter polycarbonate wheels 
- Easy installation** into any rack 
- Ideal solution** for retrofitting 





STORE / CONVEY

Modular Pallet Conveyor Platform **MPP**

A combination of **pallet conveyor modules** (roller or chain conveyors) and **specialized conveyors** such as transfers and turntables.

A complete range of modular conveyors

Quick and easy maintenance

- Energy-efficient: **500kg with 48V**
- Effective from **+5°C to +45°C**
- Speeds from **0,1 to 0,5m/s**
- Up to **1500kg**



Full **integration** with MCP and Interroll Pallet Flow systems

The Interroll MPP is a proven, high-quality solution for the entire flow of pallets throughout manufacturing plants and distribution centers.

Learn more on the next page



STORE



50%
SPACE SAVINGS
IN HIGH DENSITY
STORAGE APPLICATIONS



Pallet Flow

-  **MSC**
brakes
-  **Energy-efficient**
solution
-  **Reduced distances**
fewer forklifts, less traffic



-  **Maintenance-free,**
quick and easy to install
-  **No power required,**
gravity solution
-  **Compatible**
with your WMS
-  **Increased operator safety**
thanks to speed control
and pallet separators

FIFO and LIFO solutions for diverse applications

- Storage
- Buffer
- Dispatch Lanes
- Pick Tunnels

LIFO In/Out

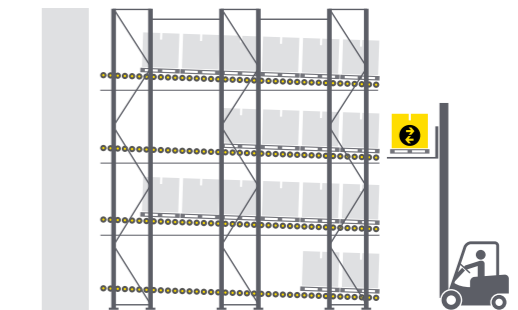

In FIFO Out

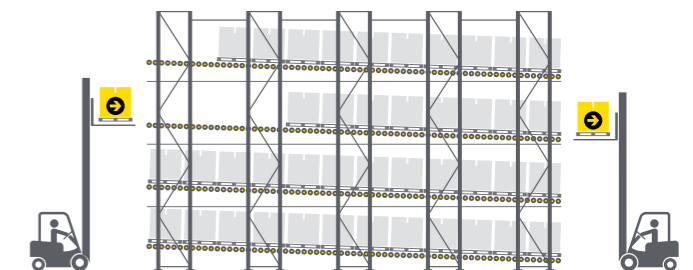

INTERROLL Lifetime SERVICE

The Interroll Lifetime Service team is here to help, giving you peace of mind for the entire service life of your material-handling equipment.

Trust us to be there — no matter the situation, you can always count on Interroll for prompt and dependable service.

Early project and operation phase

- ⌚ Time savings on installation and commissioning
- ⌚ Reduced downtime during ramp-up and operation
- 👨‍🔧 Training for your maintenance team
- 🛡️ Risk mitigation with warranty extensions

Operation of new equipment

- 📄 Customized Service Level Agreements (SLAs)
- 📞 Qualified hotline support
- 🚚 Short delivery times & express deliveries for spare parts
- 🔧 High equipment availability with professional maintenance

Operation of mature equipment

- 📊 Full transparency of your equipment's condition with audits and inspections
- 🔧 Express repairs, on site or in our repair shops
- 🔧 Future-proof equipment with our retrofit and upgrade offers

and much more!

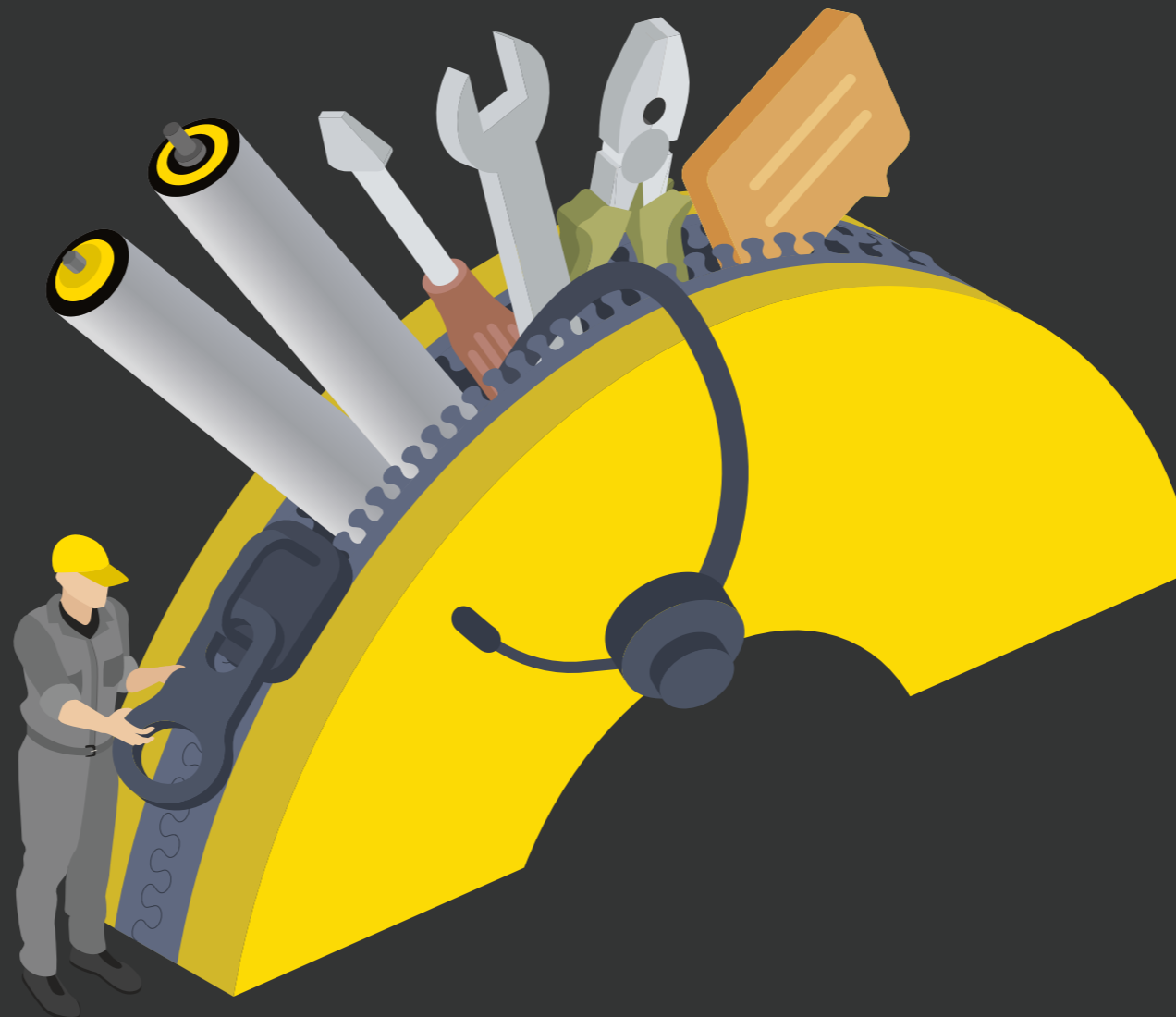

Get in touch

FOR MORE DETAILS ON YOUR LOCAL LIFETIME SERVICE OFFERING, PLEASE SCAN THE QR CODE



Forget about unexpected downtime and focus on what you do best:
Running your business successfully

 **INSTALLATION**

 **HOTLINE SUPPORT**

 **SPARE PARTS**

 **REPAIR NETWORK**

 **TRAINING**

 **AUDITS**

 **PREVENTIVE MAINTENANCE**

 **RETROFIT**



interroll.com



rollingoninterroll.com



lifetimeservice.interroll.com

About Interroll

The Interroll Group is the world's leading provider of material handling solutions. The company was founded in 1959 and has been listed on the SIX Swiss Exchange since 1997.

Interroll supplies system integrators and equipment manufacturers with a comprehensive range of platform-based products and services in the categories "Rollers" (conveyor rollers), "Drives" (motors and drives for conveyor systems), "Conveyors & Sorters" (conveyors & sorters) and "Pallet Handling" (pallet conveying and storage). Interroll solutions are used in express and postal services, e-commerce, airports, food & beverage, fashion, automotive and other industries. The company counts leading brands such as Amazon, Bosch, Coca-Cola, DHL, Nestlé, Procter & Gamble, Siemens, Walmart and Zalando among its users.

Headquartered in Switzerland, Interroll has a global network of 36 companies with sales of CHF 527.1 million and around 2,300 employees (average number of employees in 2024).

[interroll.com](https://www.interroll.com)

Interroll reserves the right to modify the technical features of its products at any time. Technical information, volumes, data and features are only rough guidelines.

© Interroll 2026

EN/01-26/UM/BRO-3.1

