



CATALOG

HIGH PERFORMANCE CONVEYOR

PLATFORM



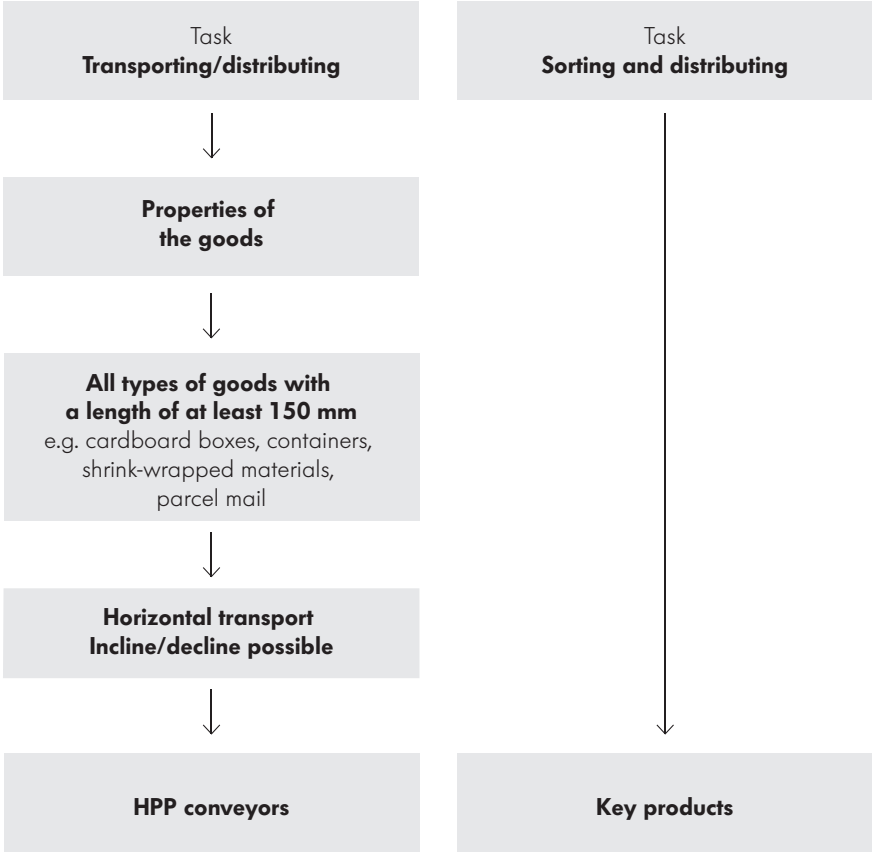

Symbols

24V	Voltage 24 V
48V	Voltage 48 V
400V	Voltage 400 V

Contents

The Interroll Group	4
Product overview	8
Belt conveyors	10
Roller conveyors	24
Key products	32
Accessories	34



THE INTERROLL GROUP

The Interroll Group is a globally leading supplier of high-quality key products and services for internal logistics. The company, which is listed on the stock exchange and has its headquarters in Switzerland, employs some 2300 people (in 2024) in 36 companies (in 2024) around the globe.

The solutions for our customers' daily logistical challenges are based on Interroll key products that are built on a worldwide common platform.



Holding



Sales, Production & Service



Global Competence Centers



Regional Competence Centers

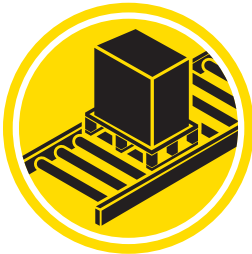

Pallet & Carton Flow

Interroll Pallet Flow and Carton Flow are the first choice when it comes to rapid turnarounds and optimizing the storage and commissioning process.

Thanks to its efficiency and robustness, Pallet Flow ensures long-term availability and more flexibility for peaks in orders. The compact design reduces space requirements by up to 50 percent compared to conventional solutions. The integrated TimePlus Separator as well as the Magnetic Speed Controller increase the safety of the work environment and significantly reduce the risk of damages to goods.

The Interroll Carton Flow solutions are efficient as well as ergonomic, and were developed to improve the commissioning output.



Drives and Controls

Interroll is a leading manufacturer in the segment of DC motor rollers and drum motors.

Interroll RollerDrive and their controls are used in automated conveyor technology. Energy-efficient DC drives are installed in decentralized conveyor systems and, as a result, optimize energy demand and material handling. The bus interface enables integrating the zero pressure accumulation conveyor technology into Industry 4.0 systems.

Interroll Drum Motors are designed for use in belt conveyors and conveyor systems. These robust, high-quality belt drives enable the construction of maintenance-free, energy-efficient conveyor belt systems for the majority of industrial applications as well as for food processing, baggage handling and supermarket checkouts.



Conveyor Rollers

Interroll is the worldwide leading provider of conveyor rollers that can be found in a multitude of applications in internal logistics. For the roller production, we merge quality, flexibility and speed. More than 13 million rollers in 60,000 variants leave our plants worldwide every year. Our production is always order-driven, even for the smallest order quantities and, if desired, even with a delivery time of 24 hours. Proven.



Conveyors & Sorters

The Modular Conveyor Platform (MCP) from Interroll offers maximum flexibility: A wide spectrum of modules, consisting of roller conveyors, belt conveyors and key products such as diverters, high-performance deflection stations and spiral lifts, covers all material handling requirements. The Interroll Crossbelt Sorters were developed precisely for fast and accurate sorting of goods of all types from 50 g to 50 kg. More than 500 Interroll sorters are used every day by the largest CEP players and E-commerce enterprises worldwide.

The High Performance Conveyor Platform (HPP) now makes the advantages of a flexible modular system of conveyor modules available to system integrators and end users in the courier, express and parcel services industry as well. This is our perfect answer to applications requiring high throughput, reliability and robustness.

The Modular Pallet Conveyor Platform (MPP) offers roller and chain conveyors as well as special conveyors such as diverters and turntables to create a fully integrated, robust, space-saving and energy-saving solution for high throughput handling of pallets.

With the Special Hygienic Conveyor (SHC), Interroll offers a proven modular platform specifically for packaged food applications – an easy to integrate platform made of stainless steel that takes into account fundamental required hygiene standards.

The Light Conveyor Platform (LCP) stands for quickly available and flexible predefined modules. It is primarily used in the production and manufacturing industry as well as in the area of assembly and automation.

In addition, we now offer the LCP AMR Top module as a seamless extension for autonomous mobile robots. This solution is frequently used for automating tasks of a repetitive nature that still require flexibility or with the goal of avoiding heavy work for humans. This platform family was primarily designed for manufacturing and assembly applications.

HIGH PERFORMANCE CONVEYOR PLATFORM

With its High Performance Conveyor Platform (HPP), Interroll has expanded its existing range of products for system integrators and machine builders whose customers include courier, express, and parcel services providers (CEP). The flexible, modular solution for belt conveyors not only offers an impressively robust design, high throughput, and short implementation times, it also

includes an intelligent diverter module that can be used for preliminary sorting in conjunction with powerful sorting systems or as an autonomous mini sorter. Using this solution, courier, express, and parcel service providers can substantially increase the degree of automation and the capacity of their distribution networks – even in fairly small package centers.



HIGH PERFORMANCE CONVEYOR PLATFORM



Modular platform

The platform consists of a number of modules, which can be adapted to the specific needs of the customer. It can also be used in applications requiring incline and decline conveyors. This enables a wide range of configurations, offering customers maximum flexibility and scalability. Alongside the Multibelt Switch, the 2-in-1 Merge is another module that allows customers to tailor the platform to their specific needs by merging two conveyor lines into one to ensure a smooth and seamless material flow.



Flexibility and scalability

The key advantages of the platform include its flexibility and scalability. The solution is suitable for a diverse range of goods. This includes boxes, parcels, large mailer boxes, polybags, paper sacks, etc. and allows adaptation to specific customer needs. The standardized modules can be easily integrated into new or existing systems.



Quick installation

The High Performance Conveyor Platform is based on a modular concept and consists of a number of modules that can be adapted to the requirements of the customer. The standardization of the modules ensures that they can be installed very quickly. The design of the side guides has also been well thought out. Thanks to their symmetrical and modular structure, they use only a few standardized components for the left and right conveyor sides alike. The modular structure yields tremendous time savings during installation.



Simple layout creation

With the Interroll Layouter tool, customers can design, plan and virtually operate entire applications. This makes the process simpler, faster, and more reliable while offering a highly realistic three-dimensional representation.

PRODUCT OVERVIEW

Belt conveyors

Straight

400 V drive

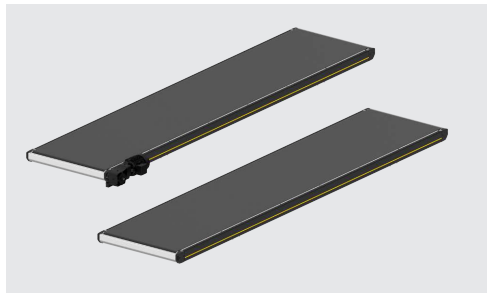

BM 1110 / BM 1111 | page 10



BM 1120 / BM 1121 | page 12



BM 1130 / BM 1131 | page 14

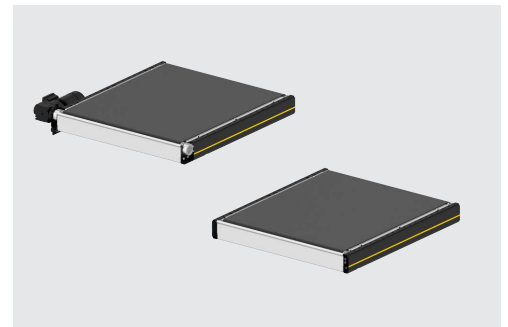

BM 1140 / BM 1141 | page 18

Merge

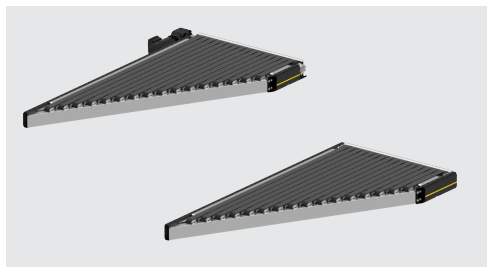

BM 1150 / BM 1151 | page 20

Roller conveyor

Merge

48 V drive



RM 1220 | page 28

Alignment conveyor

400 V drive

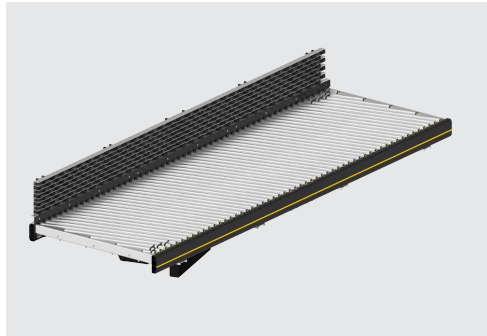

RM 1210 | page 24

Key products

Diverter

400 V drive

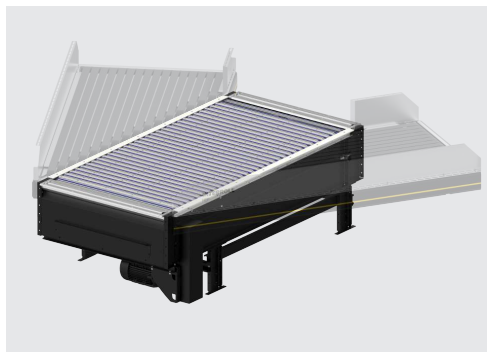

BM 1300 | page 32

Accessories



AC 1900 | page 34



Sensor kit | page 36



Reflector kit | page 36

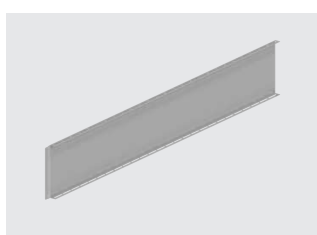

Side guide | page 36

BELT CONVEYORS

BM 1110 / BM 1111

Straight
Head drive

24V

48V

400V



Product description

The belt conveyor with head drive is characterized by robustness, speed, and a flat design. It is suitable for transporting all types of goods, such as cardboard boxes, parcels, plastic containers and polybags. New transition profiles prevent the goods from getting stuck at the transitions.

The belt conveyor is available with a gear motor (BM 1110) or drum motor (BM 1111).

Scope of delivery

- Module is completely assembled, maybe split into sections
- Please order supports and other accessories separately.

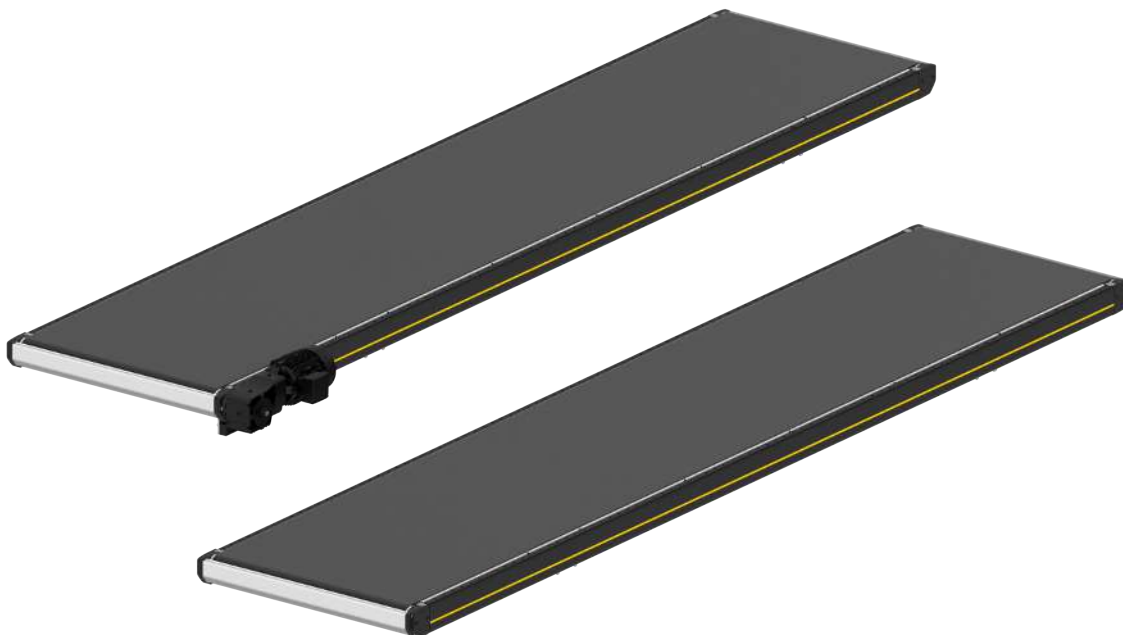

BELT CONVEYORS

BM 1110 / BM 1111

Straight
Head drive

Technical data

General technical data	
Max. load capacity	50 kg/m
Average load capacity	30 kg/m
Max. load capacity per module	350 kg
Conveyor speed	0.3 to 2.5 m/s
Incline/decline	Max. 3°
Ambient temperature	+5 to +40 °C
Drive	
Rated voltage	400 V
Electrical power	Max. 1.1 kW (drum motor), max. 3 kW (gear motor)
Motor type	Drum motor/gear motor
Materials	
Conveyor belt	Smooth, 2-layer, PVC
Slider bed	Zinc-plated sheet steel 3 mm

Combination of the maximum values is not always possible.

Dimensions

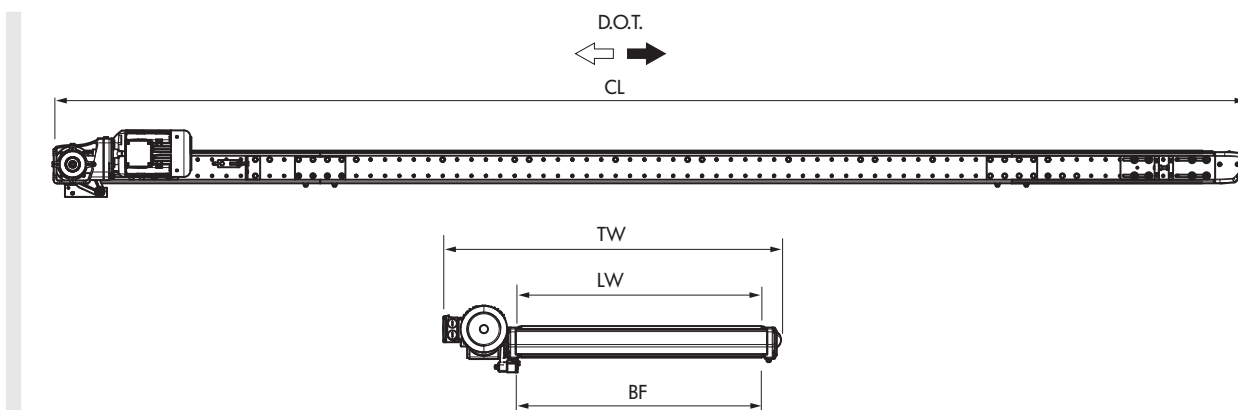

Fig.: Dimensional drawing with gear motor

BF	Rated width	620, 840, 1025, 1225 mm
LW	Clear width	BF
CL	Module length	1200 – 12000 mm
TW	Module width	BF + 375 mm (gear motor), BF + 100 mm (drum motor)
	Side guide height	150, 300, 600 mm

BELT CONVEYORS

BM 1120 / BM 1121

Straight
Center drive

24V

48V

400V



Product description

The belt conveyor with center drive is characterized by robustness, speed, and long length. It is suitable for transporting all types of goods, such as cardboard boxes, parcels, plastic containers and polybags. New transition profiles prevent the goods from getting stuck at the transitions.

The belt conveyor is available with a gear motor (BM 1120) or drum motor (BM 1121).

Scope of delivery

- Module is completely assembled, maybe split into sections
- Please order supports and other accessories separately.



BELT CONVEYORS

BM 1120 / BM 1121

Straight
Center drive

Technical data

General technical data	
Max. load capacity	50 kg/m
Average load capacity	30 kg/m
Max. load capacity per module	550 kg
Conveyor speed	0.3 to 2.5 m/s
Incline/decline	Max. 3°
Ambient temperature	+5 to +40 °C
Drive	
Rated voltage	400 V
Electrical power	Max. 2.2 kW (drum motor), max. 7.5 kW (gear motor)
Motor type	Drum motor/gear motor
Materials	
Conveyor belt	Smooth, 2-layer, PVC
Slider bed	Zinc-plated sheet steel 3 mm

Combination of the maximum values is not always possible.

Dimensions

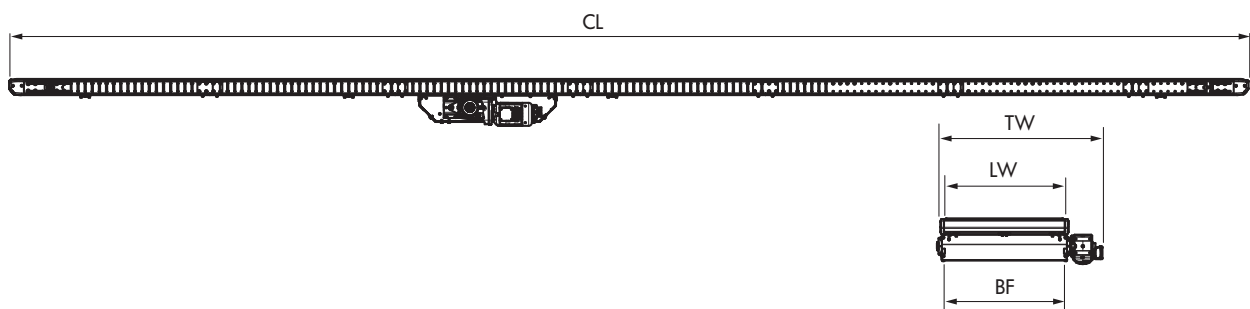

Fig.: Dimensional drawing with gear motor

BF	Rated width	620, 840, 1025, 1225 mm
LW	Clear width	BF
CL	Module length	2420 to 20000 mm
TW	Module width	BF + 125 mm (drum motor), BF + 425 mm (gear motor)
	Side guide height	150, 300, 600 mm

BELT CONVEYORS

BM 1130 / BM 1131

Straight

Center drive + upper arch

24V

48V

400V



Product description

The belt conveyor with center drive and a top arch can be used to transport all types of goods on inclines or declines. The arch reduces noise and the impact of the conveyed goods as they pass over the arch.

The belt conveyor is available with a gear motor (BM 1130) or drum motor (BM 1131).

Scope of delivery

- Module is completely assembled, maybe split into sections
- Please order supports and other accessories separately.



BELT CONVEYORS

BM 1130 / BM 1131

Straight
Center drive + upper arch

Technical data

General technical data	
Max. load capacity	50 kg/m
Average load capacity	30 kg/m
Max. load capacity per module	550 kg
Conveyor speed	0.1 to 2.5 m/s
Incline/decline	Max. 18°
Ambient temperature	+5 to +40 °C
Drive	
Rated voltage	400 V
Electrical power	Max. 2.2 kW (drum motor), max. 7.5 kW (gear motor)
Motor type	Drum motor/gear motor
Materials	
Conveyor belt	2-layer, PVC, grooved longitudinally
Slider bed	Zinc-plated sheet steel 3 mm

Combination of the maximum values is not always possible.

BELT CONVEYORS

BM 1130 / BM 1131

Straight

Center drive + upper arch

24V

48V

400V



Dimensions

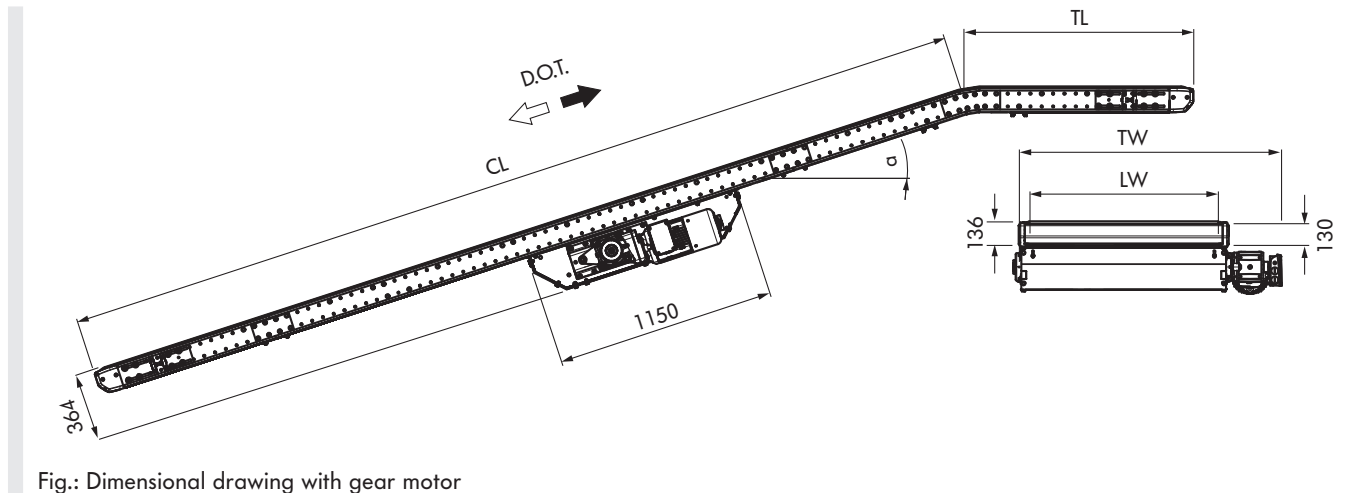

Fig.: Dimensional drawing with gear motor

BF	Rated width	620, 840, 1025, 1225 mm
LW	Clear width	BF
ML	Module length	2420 – 16980 mm, depending on the incline 6° and 9°: max. 16980 mm 12° and 15°: max. 13980 mm 18°: max. 10980 mm
CL	Length of incline or decline section	ML – TL
TL	Top length	892 – 1980 mm
TW	Module width	BF + 125 mm (drum motor), BF + 385 mm (gear motor)
HSG	Side guide height	150, 300, 600 mm
α	Incline/decline angle	6°/9°/12°/15°/18°

BELT CONVEYORS
BM 1130 / BM 1131
Straight
Center drive + upper arch

Belt conveyors

Roller conveyors

Key products

Accessories

BELT CONVEYORS

BM 1140 / BM 1141

Straight
Metering

24V

48V

400V



Product description

The metering belt conveyors are suitable for dynamic transport and creating gaps between the products. The design enables short, wide belts and high acceleration of the goods. Thanks to the use of drum motors, Interroll offers a compact layout that is perfect for situations where space is limited.

The belt conveyor is available with a gear motor (BM 1140) or drum motor (BM 1141).

Scope of delivery

- Module is completely assembled, maybe split into sections
- Please order supports and other accessories separately.

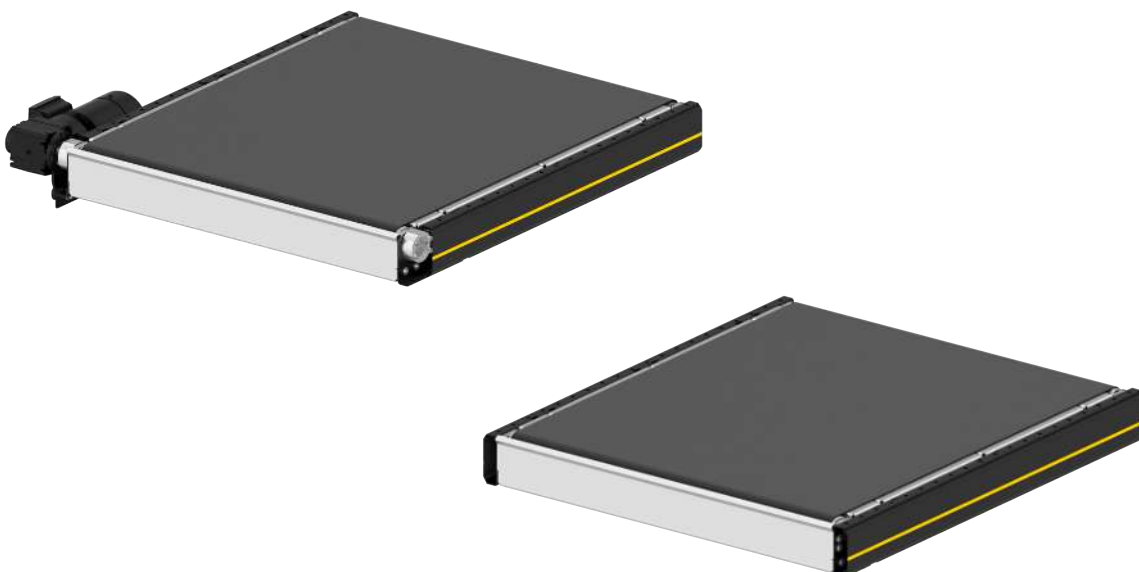

BELT CONVEYORS

BM 1140 / BM 1141

Straight
Metering

Technical data

General technical data	
Max. load capacity	50 kg/m
Conveyor speed	0.1 to 3.0 m/s
Max. electrical power per zone	0.75 kW
Incline/decline	Not suitable
Ambient temperature	+5 to +40 °C
Drive	
Rated voltage	400 V
Motor type	Drum motor/gear motor

Combination of the maximum values is not always possible.

Dimensions

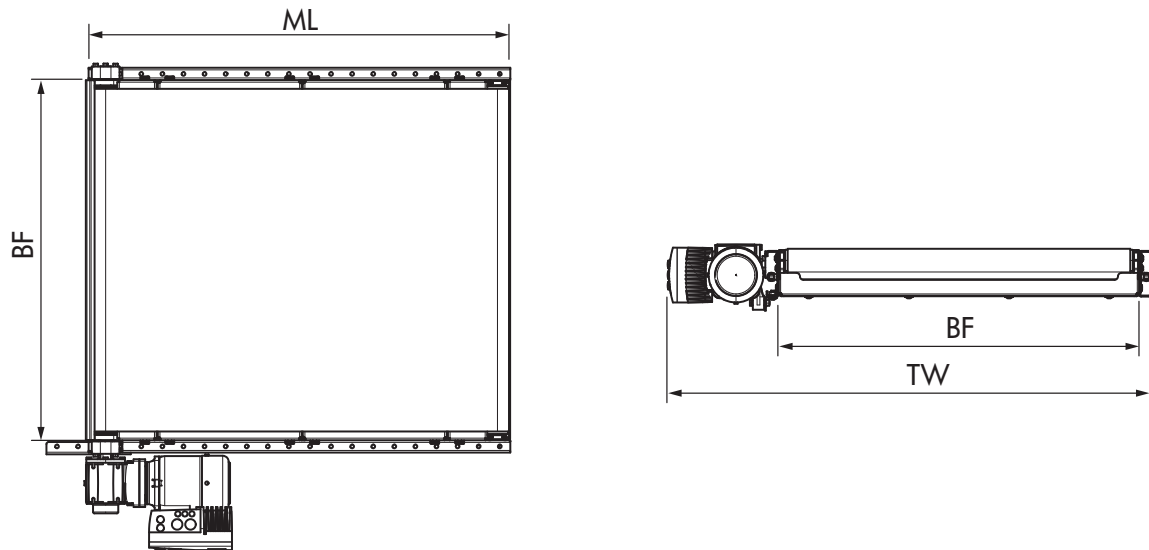

Fig.: Dimensional drawing with gear motor

BF	Rated width	620, 840, 1025, 1225 mm
LW	Clear width	BF
ML	Module length	540, 720, 1080, 1440, 1800, 1980 mm
TW	Module width	BF + 100 mm (drum motor), BF + 375 mm (gear motor)
	Side guide height	150, 300, 600 mm

BELT CONVEYORS

BM 1150 / BM 1151

Merge
Powered

24V

48V

400V



Product description

The strip conveyor Merge is a conveyor belt with a connecting edge that is angled at 30° or 45°. It allows the merging of two conveyor lines at the corresponding angle. In conjunction with additional sorting elements, it can also separate the material flow.

The belt conveyor is available with a gear motor (BM 1150) or drum motor (BM 1151).

Scope of delivery

- Module is completely assembled and prewired
- Please order supports and other accessories separately.

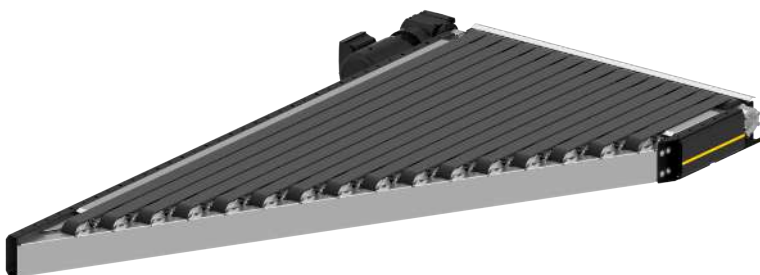

BELT CONVEYORS

BM 1150 / BM 1151

Merge
Powered

Technical data

General technical data	
Max. load capacity	50 kg/m
Max. load capacity per zone	50 kg
Conveyor speed	0.1 to 3.0 m/s
Max. electrical power per zone	0.75 kW
Incline/decline	Not suitable
Ambient temperature	+5 to +40 °C
Merging angle	30° 45°
Drive	
Rated voltage	400 V
Motor type	Drum motor/gear motor

Combination of the maximum values is not always possible.

BELT CONVEYORS

BM 1150 / BM 1151

Merge
Powered

24V

48V

400V



Dimensions

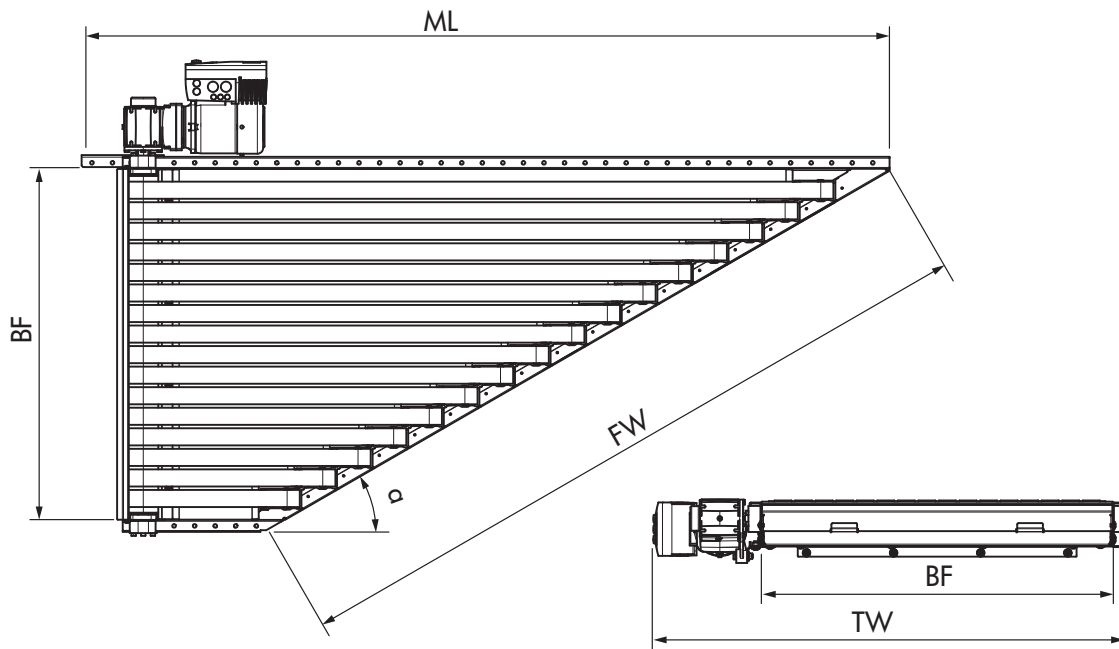

Fig.: Dimensional drawing with gear motor

BF	Rated width	620, 840, 1025, 1225 mm
LW	Clear width	BF
ML	Module length	Depending on the angle, see table below
TW	Module width	BF + 100 mm (drum motor), BF + 375 mm (gear motor)
FW	Opening width	Depending on the angle, see table below
α	Angle	30°/45°
	Side guide height	150, 300, 600 mm

BF [mm]	Angle [°]	ML [mm]	FW [mm]
620	30	1595	1380
	45	1105	679
840	30	1992	1820
	45	1335	1287
1025	30	2308	2190
	45	1518	1549
1225	30	2638	2590
	45	1708	1831

BELT CONVEYORS

BM 1150 / BM 1151

Merge
Powered

Belt conveyors

Roller conveyors

Key products

Accessories

ROLLER CONVEYORS

RM 1210

Alignment conveyor

Powered

24V

48V

400V



Product description

The continuously driven roller conveyor guides any objects oriented perpendicular to the transport direction over to one side and aligns them properly. The vertically mounted alignment strip is based on the proven design of the modular conveyor platform MCP but features the more robust frame of the HPP platform.

Scope of delivery

- Module is completely assembled, maybe split into sections
- Please order supports and other accessories separately.

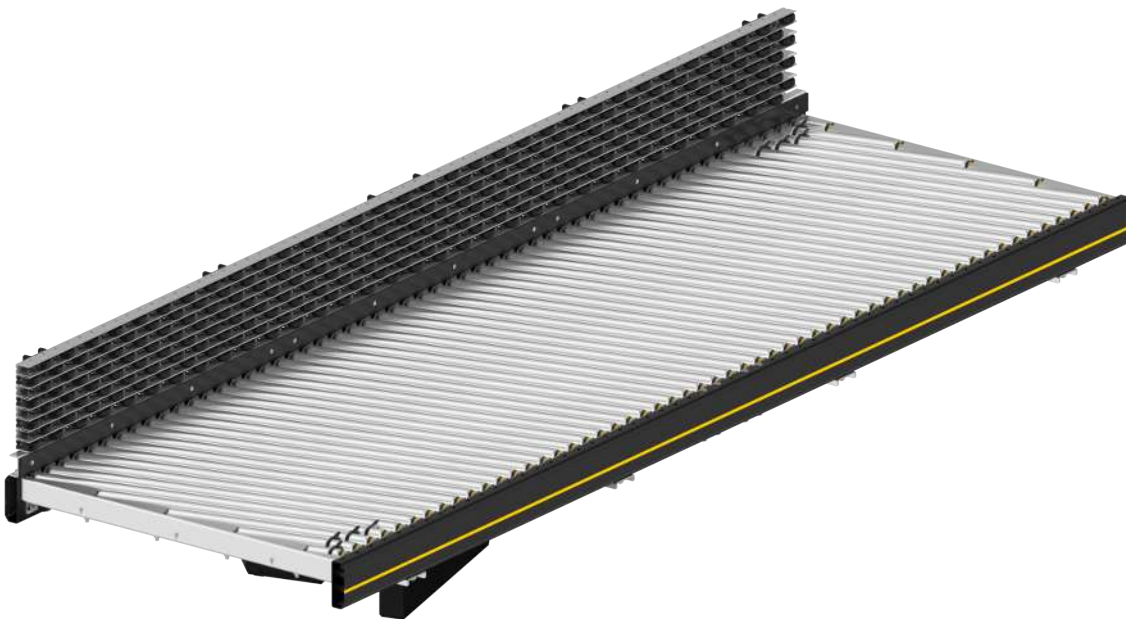

ROLLER CONVEYORS RM 1210

Alignment conveyor
Powered

Technical data

General technical data	
Max. load capacity	50 kg/m
Average load capacity	30 kg/m
Conveyor speed	0.2 – 2.5 m/s
Incline/decline	Not suitable
Ambient temperature	+5 to +40 °C
Roller	
Roller type	Interroll Series 1700
Roller diameter	50 mm
Roller material	Steel 1.5 mm, zinc-plated
Drive	
Rated voltage	400 V
Drive medium	Flat belt (transport)

Combination of the maximum values is not always possible.

ROLLER CONVEYORS

RM 1210

Alignment conveyor

Powered

24V

48V

400V



Dimensions

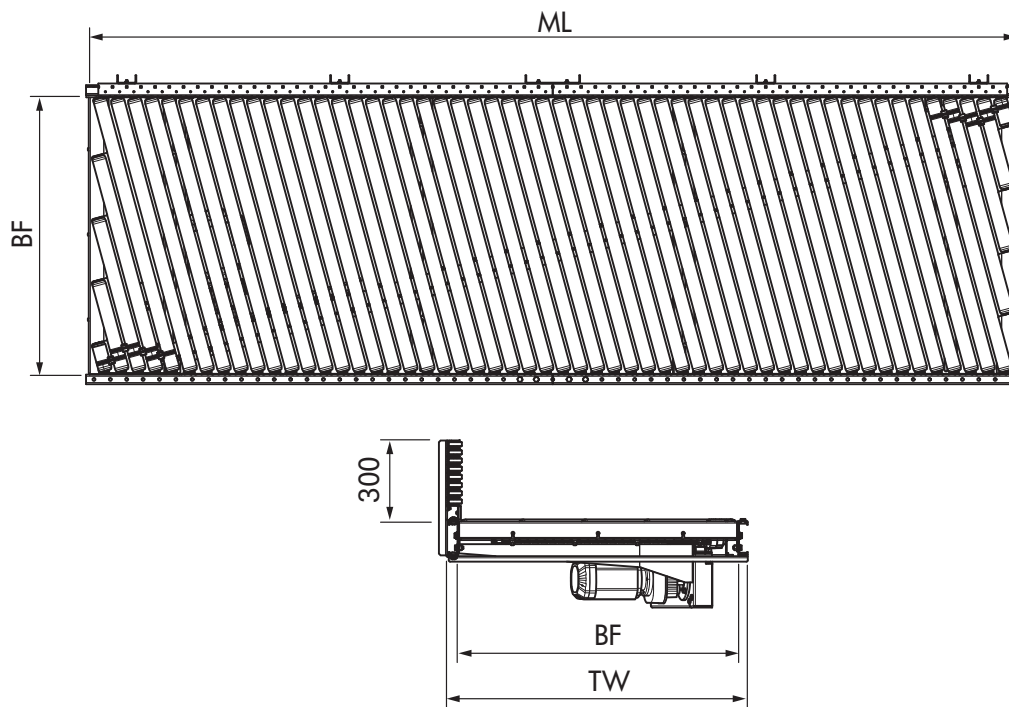

BF	Rated width	620, 840, 1025, 1225 mm
LW	Clear width	BF
ML	Transport module length	Max. 4216 mm
TW	Module width	BF + 106 mm
P	Roller pitch	60 mm
HSG	Side guide height	150, 300, 600 mm
	Conveying height	338 mm

ROLLER CONVEYORS RM 1210

Alignment conveyor
Powered

Belt conveyors

Roller conveyors

Key products

Accessories

ROLLER CONVEYORS

RM 1220

2-in1 merge

Powered

24V

48V

400V



Product description

The 2-in1 Merge brings two lines together into one. This tried-and-tested Interroll conveyor has now been standardized within the HPP platform. The roller itself is mounted at an angle and guides the products either left or right to the center line of the conveyor.

Scope of delivery

- Module is completely assembled, maybe split into sections
- Please order supports and other accessories separately.

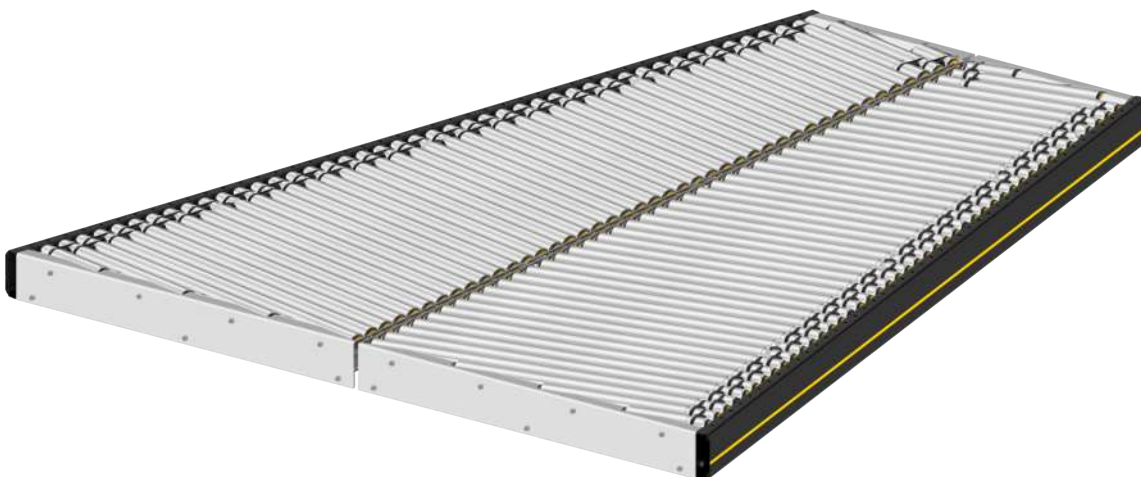

Technical data

General technical data	
Max. load capacity	50 kg/m
Average load capacity	30 kg/m
Conveyor speed	0.4 to 2.0 m/s
Max. electrical power per zone	50 W
Max. electrical power per conveyor	500 W
Incline/decline	Not suitable
Ambient temperature	+5 to +40 °C
Roller	
Roller type	Interroll Series 1700
Roller diameter	50 mm
Roller material	Steel 1.5 mm
Surface	2 mm PVC
Drive	
Rated voltage	48 V
Motor type	Interroll RollerDrive EC5000
Drive medium	Round belt
Torque transmission	Roller-to-Roller
Control variants	MultiControl

Combination of the maximum values is not always possible.

ROLLER CONVEYORS

RM 1220

2-in-1 merge

Powered

24V

48V

400V



Dimensions

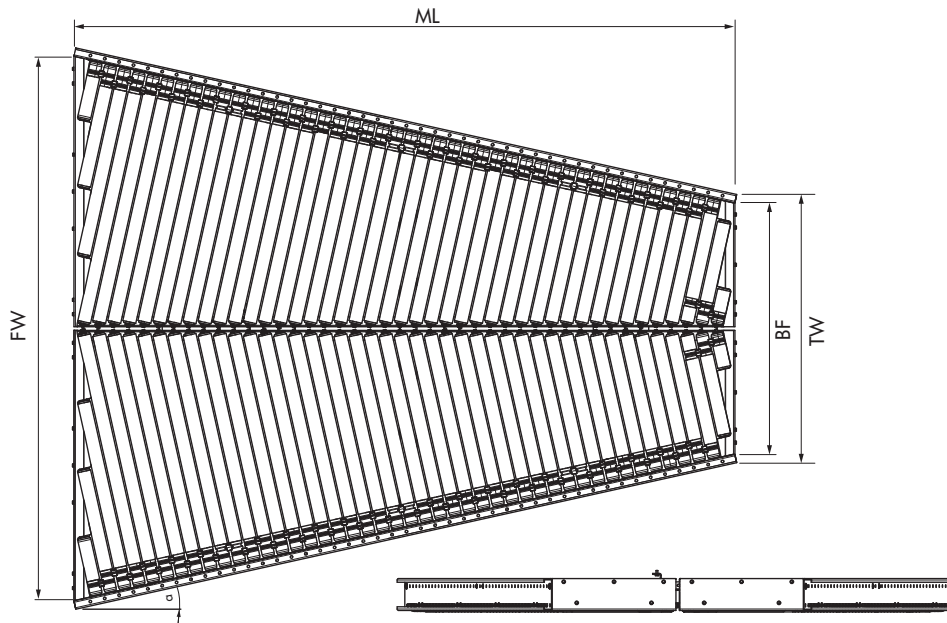

BF	Rated width	620, 840, 1025, 1225 mm
LW	Clear width	BF
ML	Module length	Depending on the design, see table below
TW	Module width	BF + 90 mm
FW	Opening width	Depending on the design, see table below
α	Angle	12.5°
	Side guide height	150, 300, 600 mm

Version	BF [mm]	ML [mm]	FW [mm]
BF620 S	620	1789	1410
BF620 L		2240	1610
BF840 S	840	2280	1850
BF840 L		2731	2050
BF1025 S	1025	2702	2220
BF1025 L		3153	2420
BF1225 S	1255	3154	2620

ROLLER CONVEYORS

RM 1220

2-in1 merge

Powered



Belt conveyors

Roller conveyors

Key products

Accessories

KEY PRODUCTS

BM 1300

Diverter
Powered

24V

48V

400V



Product description

The Multibelt Switch (MBS) is the key element of the High Performance Conveyor Platform. The diverting process works according to an entirely new and unique principle, enabling throughputs of up to 10,000 parts per hour. It brings the advantages of a reliable belt conveyor to the diverter and can also be used as an alignment conveyor. The Multibelt Switch ensures the stable and reliable transport of all types of goods and can also be used for sorting the products into multiple destinations.

Scope of delivery

- Delivered without belt conveyor (Merge)

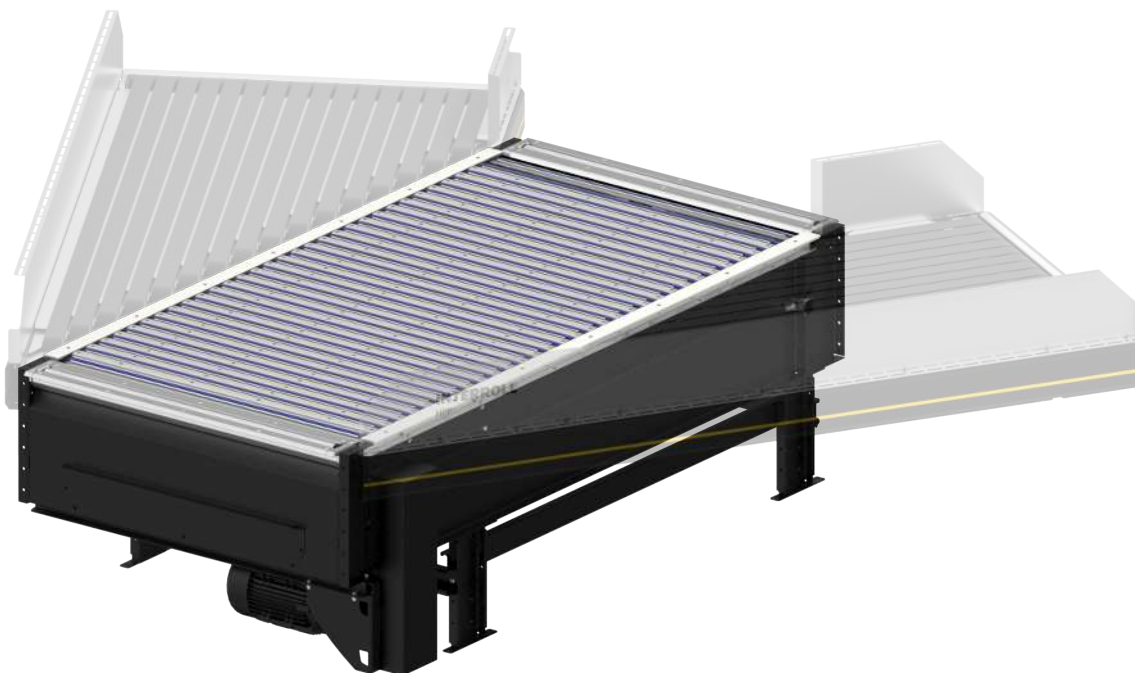

KEY PRODUCTS BM 1300

Diverter
Powered

Technical data

General technical data	
Max. load capacity	50 kg/m
Max. Speed	1.6 m/s
Diverting angle	45°
Ambient temperature	+5 to +40 °C
Transfer movement activation	
Pneumatic	4 bar
Travel motor drive	
Rated voltage of travel motor	48 V and 400 V
Control variants	PLC gateway + MultiControl BI

Combination of the maximum values is not always possible.

Dimensions

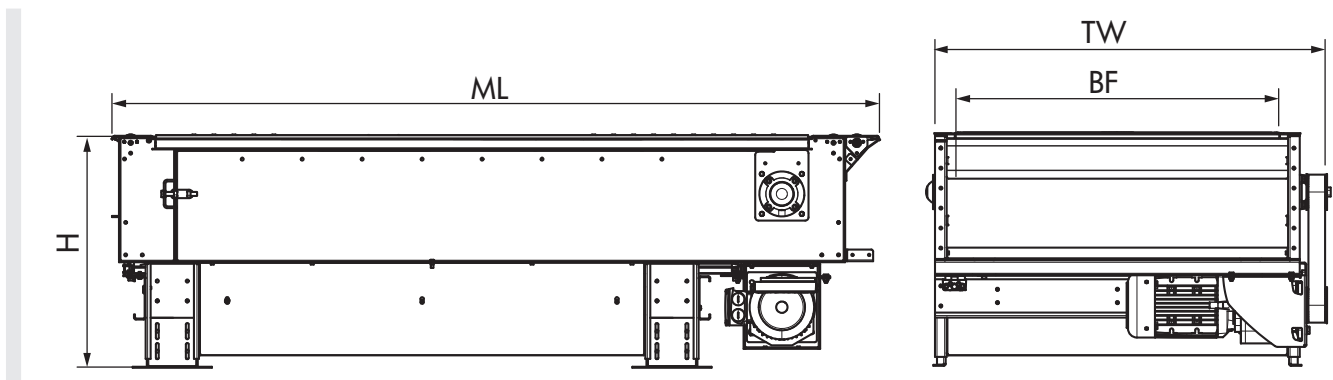

BF	Rated width	840, 1025, 1225 mm
ML	Module length	2000 – 5600 mm
	Min. conveying height	700 – 1000 mm

ACCESSORIES

AC 1900

24V

48V

400V



Product description

The support is intended for fastening the modules to the floor or lift floor. The support foot is infinitely adjustable. A simple height adjustment via threaded spindle can be ordered as an add-on.

Scope of delivery

- Infinite height adjustment with optional threaded spindle
- Support fully assembled
- Other support models on request

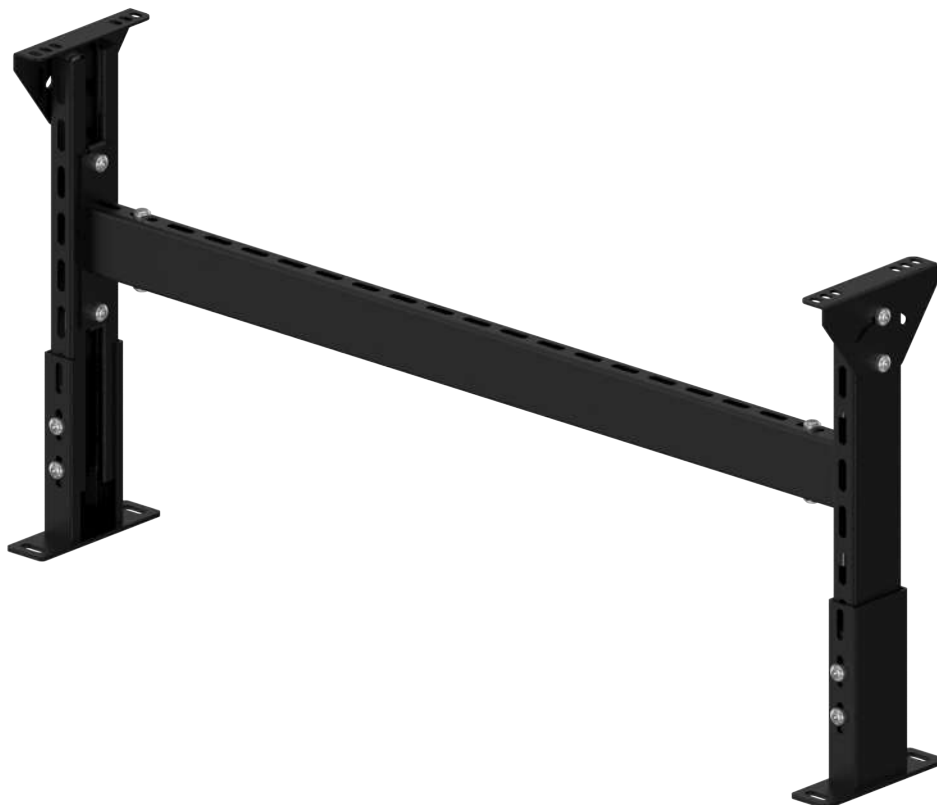

Technical data

General technical data

Max. load capacity 80 kg/m

Dimensions

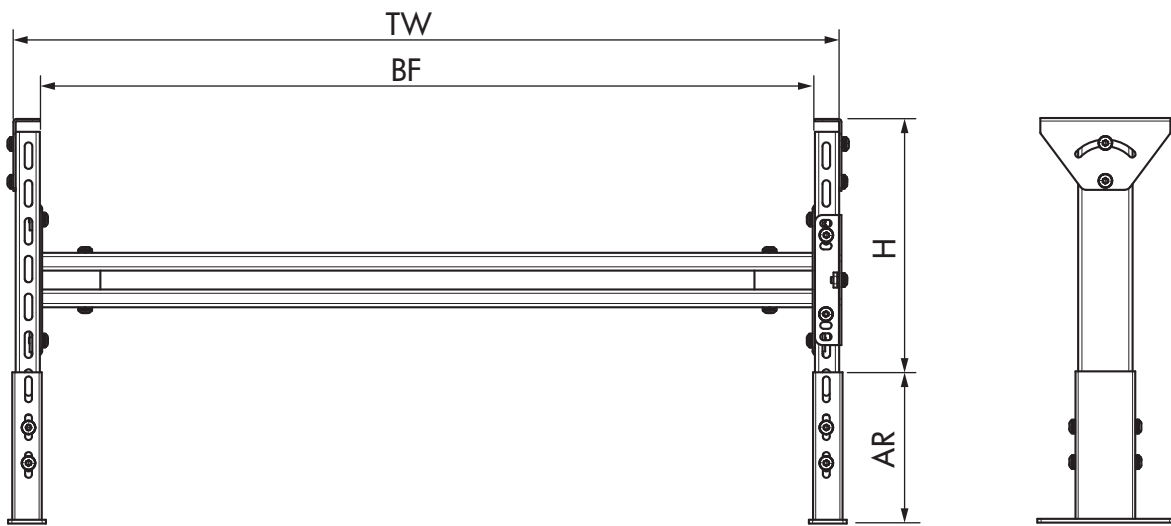

H	Height	Max. 3000 mm
AR	Adjustment range	± 50 mm
BF	Rated width	620, 840, 1025, 1225 mm

ACCESSORIES



24V

48V

400V

Sensor kit



Sensors detect materials on the conveyors and determine their position. Reflex light barriers are used, which require a reflecting mirror (reflector) on the opposite side of the light barrier in order to return the light beam.

The housing can be fastened on the roller conveyor using the universal support.

Designation	Dimensions	Reference number
Sensor kit	250 x 95 x 115 mm (L x W x H)	on request

Reflector kit



The reflector kit returns the light beam back to the sensor. The kit can be fastened directly to the side frame.

Designation	Dimensions	Reference number
Reflector kit	250 x 100 x 150 mm (L x W x H)	on request

Side guide

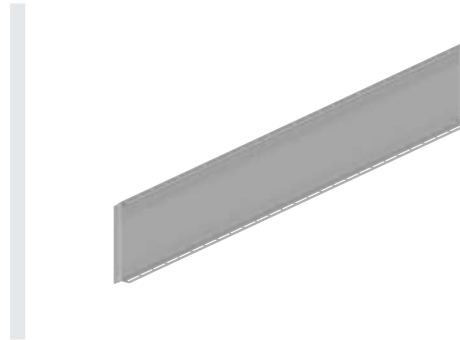

Side guides are used for reliably guiding the product on roller conveyors and belt conveyors, as well as on the corresponding components. We offer the side guides in a zinc-plated sheet steel design.

Designation	Dimensions	Reference number
Side guide	2000 x 35 x 600 mm 2000 x 35 x 300 mm 2000 x 35 x 150 mm 1000 x 35 x 600 mm 1000 x 35 x 300 mm 1000 x 35 x 150 mm 500 x 35 x 600 mm 500 x 35 x 300 mm 500 x 35 x 150 mm	on request

The dimensions of all accessories depend on the requested design.



The Interroll Center of Excellence in Sinsheim, Germany, near Heidelberg, concentrates on subsystems and modules implemented at key internal logistics points. These include roller conveyors and belt conveyors, belt curves and crossbelt sorters. In this product sector, the company is responsible within the global Interroll Group for all technical concerns ranging from development and application engineering to production and support for local Interroll companies and customers.

The 15,700 square-meter center is where the in-house design and manufacture of the entire product range takes place. This vertical integration allows us to control the quality of our products from A to Z and offer custom engineering support for our customers.

Conveyor modules, crossbelt sorters and other key products for material flow systems can be seen in the new customer center as demonstration systems. At our Interroll test center, customers can experience firsthand the testing of our custom-made configurations for new projects.

Interroll Automation GmbH

Dietmar-Hopp-Str. 3

74899 Sinsheim

Germany

+49 (0)7261 938-0

LEGAL NOTICES

Contents

We strive for the information presented to be correct, up to date and complete. We have carefully developed the contents of this document. Nevertheless, errors and changes are expressly subject to change.

Copyright/intellectual property right

Text, images, graphics and the like, as well as their arrangement, are protected by copyright and other protective legislation. Reproduction, modification, transfer or publication of any part or the entire content of this document in any form is prohibited. This document is intended exclusively for informational purposes and for intended use and does not authorize replication of the corresponding products. All identification symbols used in this document (protected trademarks, such as logos and commercial designations) are the property of Interroll AG or their respective owners and may not be used, copied or disseminated without prior written permission.

About Interroll

The Interroll Group is a globally leading provider of solutions for material handling. The company was founded in 1959 and has been listed on the SIX Swiss Exchange since 1997.

Interroll supplies system integrators and machine builders with a broad product range of platform-based products and services in the categories "Rollers" (conveyor rollers), "Drives" (motors and drives for conveyor systems), "Conveyors & Sorters" as well as "Pallet Handling" (pallet flow and storage). Solutions from Interroll are used by express and postal services, in e-commerce, in airports and in the areas of food & beverage, fashion, automotive and other industries. The company counts leading brands, such as Amazon, Bosch, Coca-Cola, DHL, Nestlé, Procter & Gamble, Siemens, Walmart, or Zalando, among its users.

Interroll, with its headquarters in Switzerland, has a global network of 36 companies with annual revenue of CHF 527.1 million and roughly 2,300 employees (in 2024).

[interroll.com](https://www.interroll.com)