



Sorter Solution Portfolio

Consider it Sorted.









Interroll in the Sorting Sector

Interroll's sortation technologies are **PROVEN** to deliver maximum performance, accuracy, and durability. From e-commerce fulfillment to Courier, Express, Parcel & Postal – CEP) logistics and distribution centers, Interroll enables fast, quiet, and modular sortation across industries. Our portfolio approach and scalable modules mean our solutions grow with your needs, keeping you ahead of industry demands.



Why Partner with Interroll?

-  **Modular Ecosystem of Excellence**
Hardware, software, and services in full harmony. Ensuring high performance, fast commissioning, and easy expansion.
-  **Global Reach, Local Expertise**
36 subsidiaries worldwide provide consistent quality, rapid deployment, and expert local support.
-  **Seamless Integration**
Solutions designed to work together for faster projects, smoother ramp-up, and reduced programming effort with tools like MCP PLAY.
-  **Efficiency That Performs**
Up to 50% energy savings, higher throughput, and low-maintenance systems for lasting cost efficiency.
-  **Scalability Without Compromise**
Future-ready modular platforms that adapt to growth, upgrades, and automation needs.
-  **24/7 Lifecycle Value**
From design to predictive maintenance and retrofits, Interroll Lifetime Service delivers peace of mind at every stage.
-  **Trusted by Global Leaders**
Amazon, DHL, Nestlé, Bosch, Coca-Cola, Siemens, and more rely on Interroll for mission-critical operations.
-  **Unmatched Reliability**
Engineered for durability to minimize downtime and maximize operational confidence.

Interroll: delivering a trusted ecosystem for smart unit flow solutions.

At Interroll, we go beyond components. We provide a modular ecosystem of reliable hardware, advanced software, scalable services, and easy-to-use tools – designed for seamless integration into customer systems to ensure system harmony from day one.

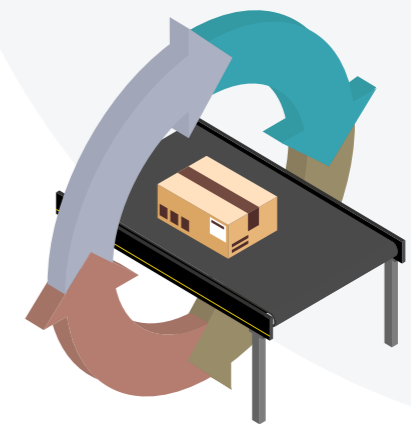

OUR PRODUCT OFFERING

Flexible Sorting Across All Key Industries

Interroll's sortation portfolio is designed for a wide range of industries with varying throughput needs. Whether you're in Courier, Express & Parcel (CEP), Food & Beverage, Manufacturing & Production Logistics, Pharmaceuticals, Warehousing & Distribution, or Retail, our systems ensure reliable, high-speed sorting with minimal downtime. From sensitive goods in pharma to rugged packaging in CEP and food-grade modular options, our sorters can be configured to match your precise operational and regulatory requirements.

HPD

p.06 **MCP WITH HIGH-PERFORMANCE DIVERT**

- Up to **3,600** items/hour
(4,150 with MCP PLAY option)
- Up to **50kg**



MC-S

p.08 **INTERROLL SORTEQ MODULAR CHAINBELT SORTER**

- Up to **8,000** items/hour
- Up to **35kg**



MBS

p.10 **MULTIBELT SWITCH**

- Up to **10,000** items/hour
- Up to **50kg**

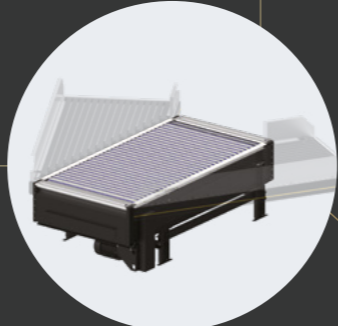

MT-S

p.12 **SPLIT-TRAY SORTER**

- Up to **21,600** items/hour (max)
- Up to **8kg**



MX-V

p.14 **VERTICAL CROSSBELT SORTER**

- Up to **14,000** items/hour
- Up to **35kg**



MX-H

p.16 **HORIZONTAL CROSSBELT SORTER**

- Up to **20,000** items/hour
- Up to **50kg**

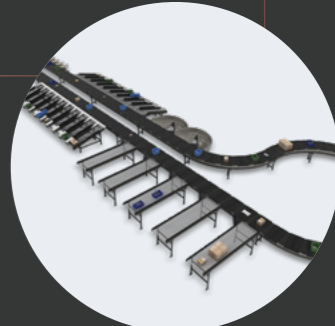
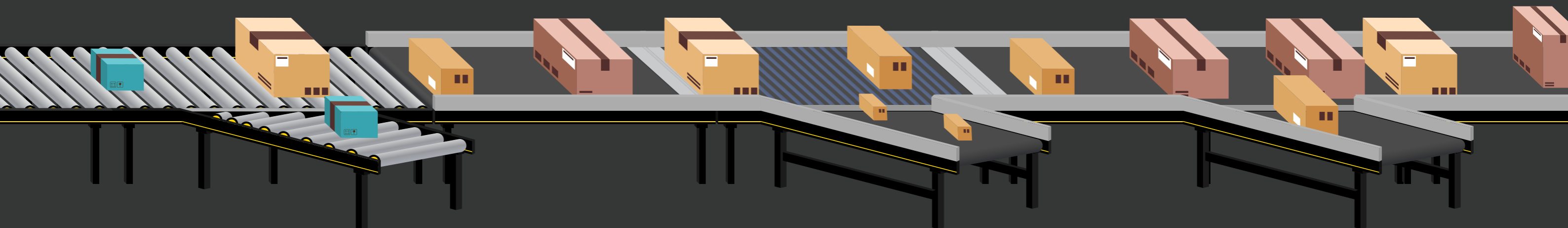

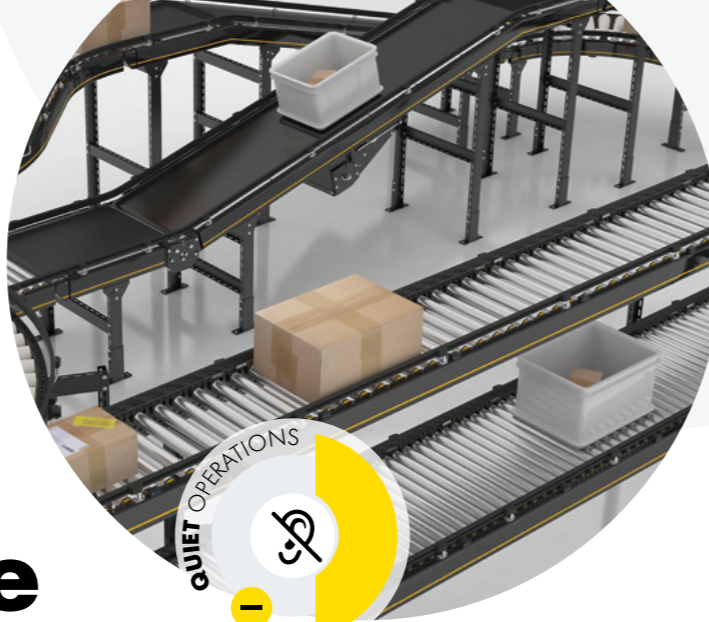

HPD

MCP with High-Performance Divert



QUIET OPERATIONS
1
< 60 dB

 Up to **3,600** items/hour
(4,150 with MCP PLAY option)

 Up to **50 kg**





The Modular Conveyor Platform (MCP) combined with High-Performance Diverts offers optimal flexibility and intelligent material flow.

Capable of speeds up to 1,4 m/s and handling loads up to 50 kg/m, MCP ensures quiet, modular and highly efficient operations across diverse intralogistics environments. The plug-and-play design enables easy layout changes and fast commissioning.

KEY BENEFITS

 **Quiet and safe operation,** ideal for employee-friendly environments

 **Modular design** for easy adaptation to layout changes

 **With MCP PLAY** option, faster commissioning and ramp-up for quicker project delivery as well as reduced programming efforts, saving time and resources



LIFTS



LIFT-UP GATE



ROLLER CURVES



STRAIGHT ROLLER CONVEYOR



MERGES



90° TRANSFERS



INCLINES / DECLINES



STRAIGHT BELT CONVEYOR



BELT MERGE

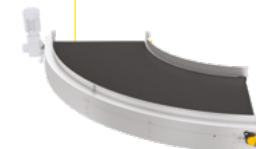

BELT CURVE

MC-S



Interroll Sortteq Modular ChainBelt Sorter

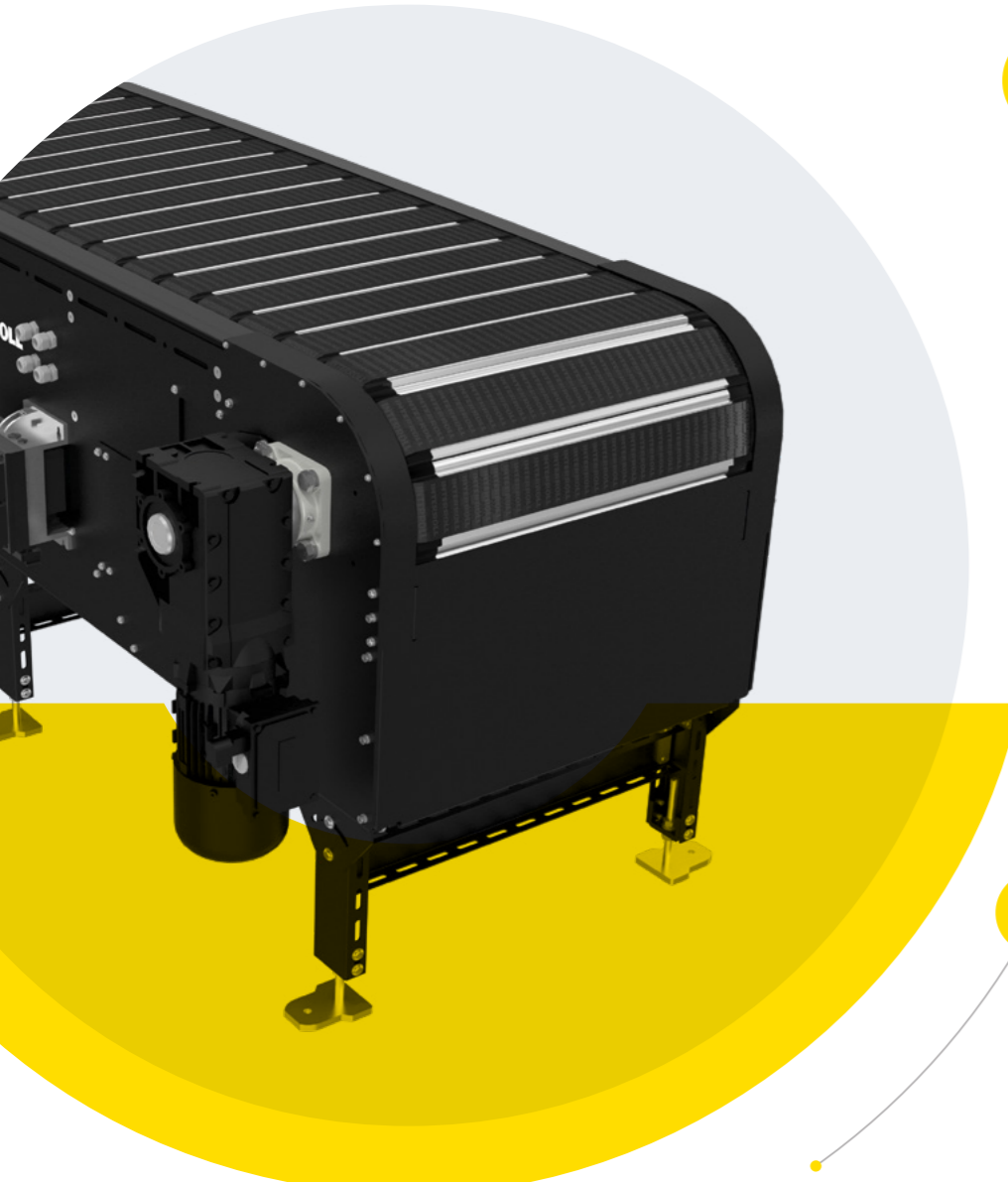

- Up to **8,000** items/hour
- Up to **35 kg**

KEY BENEFITS

- Proven mechanical design** guarantees high reliability
- Narrow belt pitch** with wide belts for process reliability for smallest item sortation
- Minimal downtime** due to a maximum maintenance friendly design

CHAIN BELT CONVEYOR

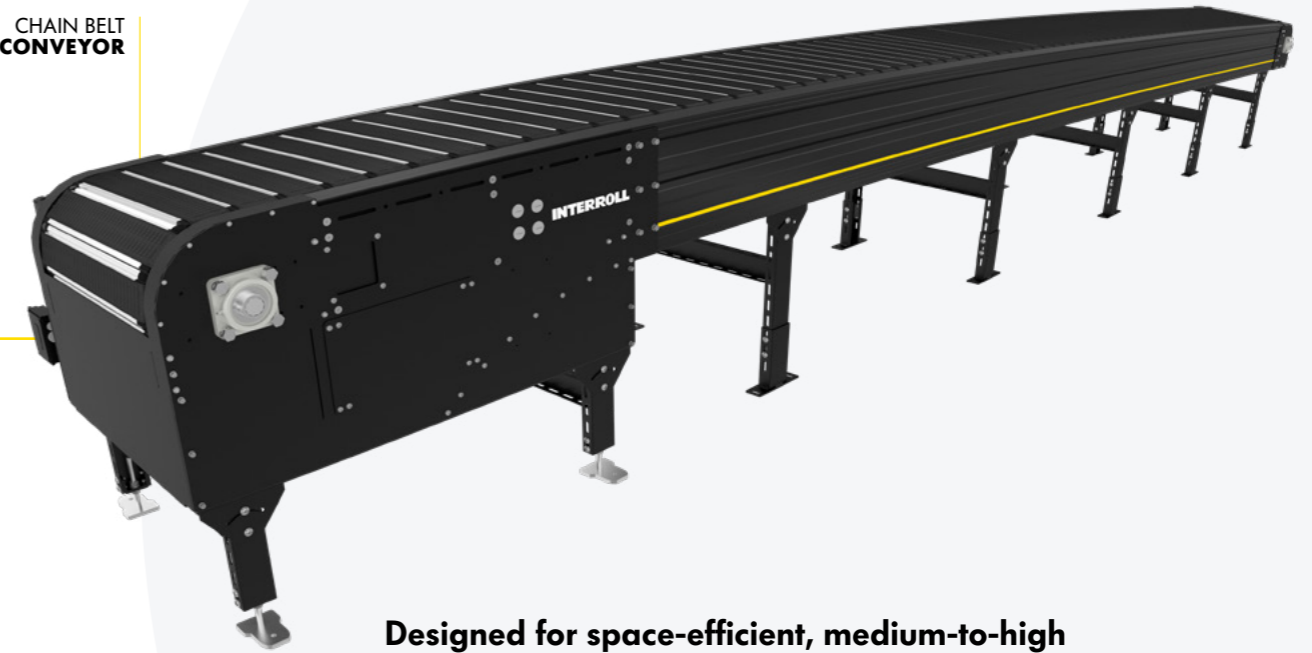

Designed for space-efficient, medium-to-high throughput applications up to 8,000 items/hour, the Interroll Sortteq Modular ChainBelt Sorter MC-S offers reliable, gentle sortation all kinds of items.

The mechanical design is built for durability, requiring minimal maintenance and providing high accuracy while allowing for an efficient use of space. This makes it suitable for handling cartons, totes, polybags, envelopes, skiffy envelopes, and unshaped items in busy distribution environments.



PROVEN SIMPLICITY

MBS

MultiBelt Switch



KEY BENEFITS

Cost-effective sorting for mid-range throughput



Low maintenance with purely mechanical components



Software included



Fast ROI with minimal energy use and simple system integration



The MultiBelt Switch (MBS) is a modular, stand-alone diverter designed for medium-throughput applications (up to 10,000 items/hour).

Ideal for flat-bottom goods like parcels as well as bags, it uses multiple narrow belts to divert products fluently and without throughput loss. It comes with its own software to easily be integrated into typical bus systems. For best performance with heavier goods and high-speed lines, it can be paired with Interroll's High-Performance Conveyor Platform (HPP).

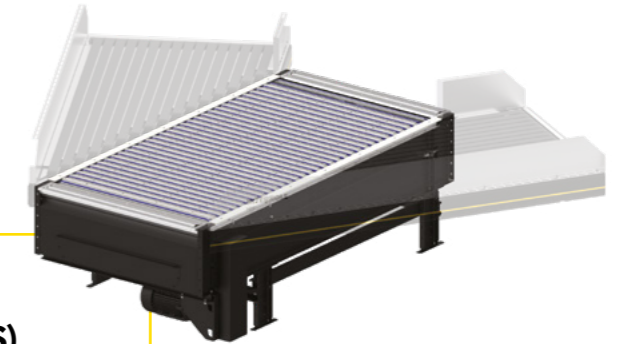

Up to **10,000** items/hour



Up to **50 kg**





MT-S

Split-Tray Sorter

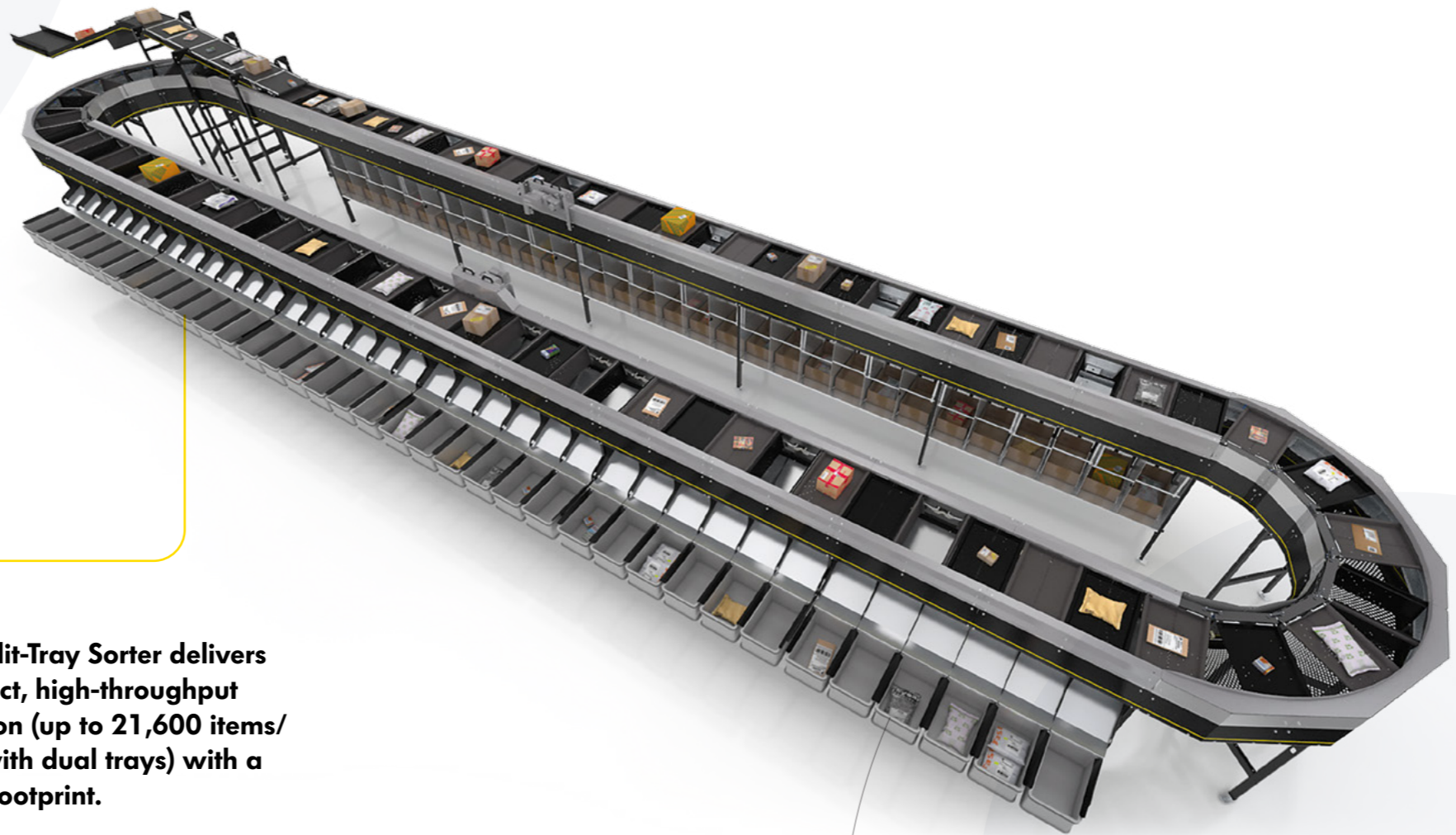

 Up to **21,600** items/hour

 Up to **8 kg**

The Split-Tray Sorter delivers compact, high-throughput sortation (up to 21,600 items/hour with dual trays) with a small footprint.

Ideal for lightweight, non-fragile items, it offers flexible configuration and precise destination control. Its modular design ensures simple expansion and seamless integration into existing layouts.

SPACE SAVING +

KEY BENEFITS

Fast ROI with high throughput and low maintenance 

Accurate placement thanks to stable mechanics 

Quiet operations for improved working environments 



MX-V

Vertical Crossbelt Sorter



KEY BENEFITS

Accurate positioning
due to refined infeed technology

Low TCO
with minimal wear
and efficient drives

Quiet operation
below 67 dB(A)



A high-throughput, space-saving solution (up to 14,000 items/hour), the Vertical Sorter features inline over-the-top infeeds, ideal for polybags, flats, and irregular items. Its vertical loop maximizes floor space and sorting density.

Up to 14,000
items/hour

Up to 35 kg

Small-wheel version available

The MX-Vs small-wheel sorter stands just 1400 mm high, runs up to 180 m long, and reaches 1.3 m/s with smooth, quiet performance.

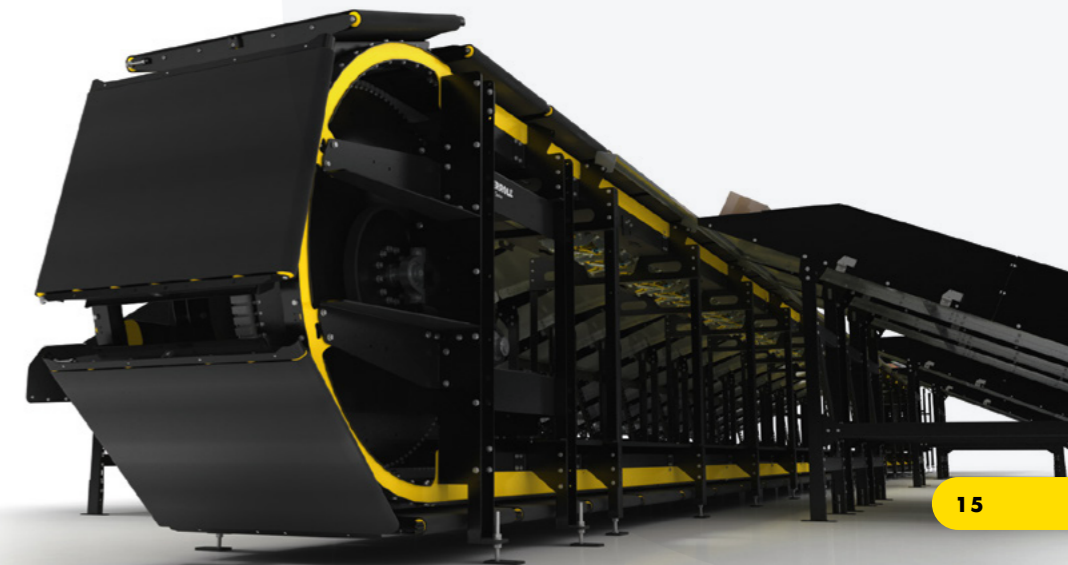

MX-H



Horizontal Crossbelt Sorter

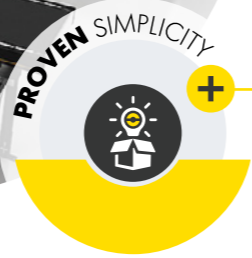

Up to **20,000** items/hour



Up to **50 kg**



KEY BENEFITS

Heavy-Duty Sorting:

Supports items up to 50 kg, suited for robust handling across sectors



Low-Maintenance Design:

Power Belt Drive eliminates lubrication needs, cutting service costs and downtime



Proven Reliability:

Over 500 installations worldwide, especially in high-volume CEP and e-commerce sectors, demonstrating durability and system confidence



Interroll's Horizontal Crossbelt Sorter (MXH) is engineered for high-speed, high-throughput operations, delivering performance of up to 20,000 items per hour at speeds reaching 2.7 m/s, all while handling payloads up to 50 kg per carrier. Its wide carriers enable the accommodation of large, bulky items.

The sorter features a lubrication-free drive chain using a durable power belt – minimizing maintenance and downtime.

INFEDS, DESTINATIONS & CONTROLS

Backed by 25 years of Interroll experience, this platform is consolidated, standardized, and highly modular, enabling fast customization through proven configurations.

Various solutions enable the handling of a wide range of products, while the Interroll Layouter tool facilitates fast layout planning and destination design.



Infeed Modules

Interroll provides optimized infeed solutions that ensure smooth and efficient transfer of goods to the sorter system.

Whether manual or automated, our high-performance infeeds manage product flow, orientation, and spacing with minimal impact on system throughput.

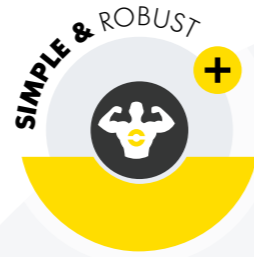

Sorter Control Systems

Interroll's intuitive control architecture supports easy integration with external systems like WMS and PLCs.

Our controls enable energy-efficient management of drives, sensors, and modules while ensuring consistent sort accuracy and throughput.

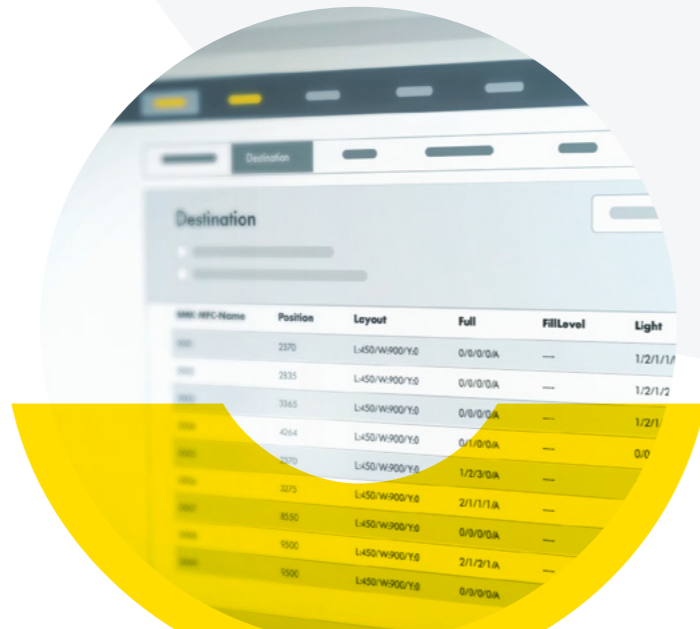

Modular Destination Platform MDP

A flexible and ready-to-use solution for discharge, the MDP accommodates a wide range of item types and weights.

It features low noise operation, optimized spacing, and tailored chutes for every application. Easily expandable, the MDP ensures precise, reliable delivery to designated output lanes.

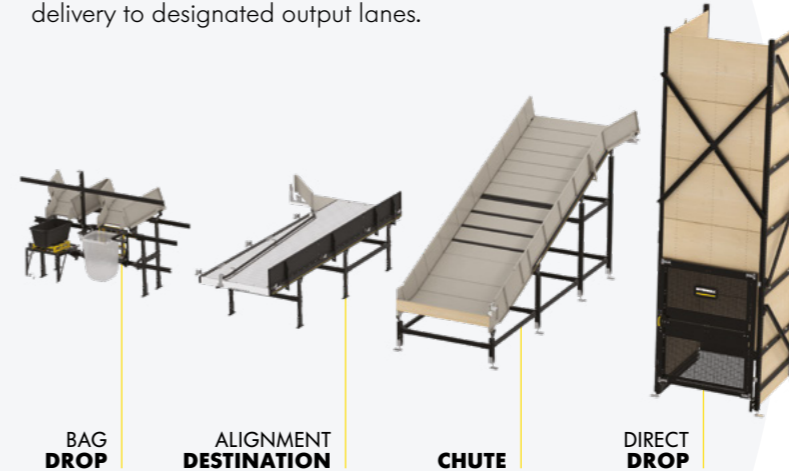

BAG DROP

ALIGNMENT DESTINATION

CHUTE

DIRECT DROP

- Layouter enables **combined 3D planning** of sorter including destinations
- Modularity enables **fast configuration** of the destinations to the customer needs
- Rapid design and procurement** enable FAT testing for time-critical projects
- Chutes can be **easily adapted** within the FAT test
- Reduced project time** through minimized engineering efforts and standardization
- Lower project risks** thanks to pre-tested components
- Quick on-site installation** thanks to pre-assembled modules
- Easy to retrofit** if future requirements change
- Also suitable for **third-party sorters**
- Pre-defined sensor** and electric concepts available



SERVICE

INTERROLL Lifetime SERVICE

The Interroll Lifetime Service team is here to help, giving you peace of mind for the entire service life of your material-handling equipment.

Trust us to be there — no matter the situation, you can always count on Interroll for prompt and dependable service.

Early project and operation phase

- ⌚ Time savings on installation and commissioning
- ⌚ Reduced downtime during ramp-up and operation
- ⌚ Training for your maintenance team
- ⌚ Risk mitigation with warranty extensions

Operation of new equipment

- ⌚ Customized Service Level Agreements (SLAs)
- ⌚ Qualified hotline support
- ⌚ Short delivery times & express deliveries for spare parts
- ⌚ High equipment availability with professional maintenance

Operation of mature equipment

- ⌚ Full transparency of your equipment's condition with audits and inspections
- ⌚ Express repairs, on site or in our repair shops
- ⌚ Future-proof equipment with our retrofit and upgrade offers

and much more!

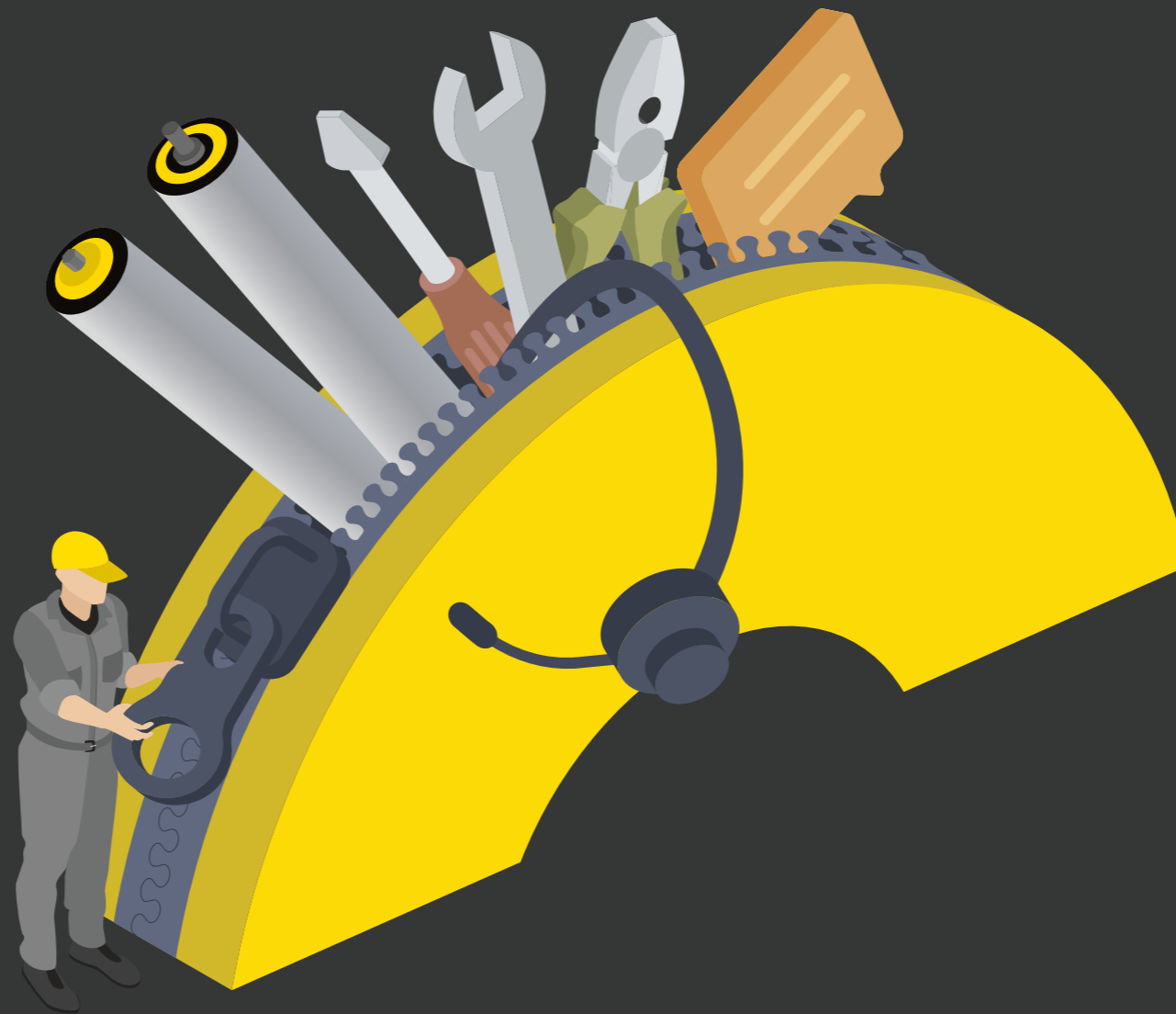

Get in touch

FOR MORE DETAILS ON YOUR LOCAL LIFETIME SERVICE OFFERING, PLEASE SCAN THE QR CODE



Forget about unexpected downtime and focus on what you do best:
Running your business successfully

 **INSTALLATION**

 **HOTLINE SUPPORT**

 **SPARE PARTS**

 **REPAIR NETWORK**

 **TRAINING**

 **AUDITS**

 **PREVENTIVE MAINTENANCE**

 **RETROFIT**

OUR GLOBAL PRESENCE

Our key products for the sortation market are developed and manufactured in the following centers:



INTERROLL ATLANTA
MCP & MPP
Conveyors, Sorters



INTERROLL LINZ
Software & Electronics



INTERROLL SINSHEIM
Sorters



INTERROLL SUZHOU
MCP & MPP
Conveyors, Sorters



The Interroll Group



36
SUBSIDIARIES &
PRODUCTION SITES



2,300
EMPLOYEES



CONTACT US

- Holding
- Manufacturing Unit
- Sales Unit
- Mixed

About Interroll

The Interroll Group is the leading global provider of material handling solutions. The company was founded in 1959 and has been listed on the SIX Swiss Exchange since 1997.

Interroll provides system integrators and OEMs with a wide range of platform-based products and services in these categories: Rollers (conveyor rollers), Drives (motors and drives for conveyor systems), Conveyors & Sorters as well as Pallet & Carton Flow (flow storage systems). Interroll solutions are in operation in express and postal services, e-commerce, airports, the food and beverage industry, fashion, automotive sectors, and many other manufacturing industries.

Among the company's end users are leading brands such as Amazon, Bosch, Coca-Cola, DHL, Nestlé, Procter & Gamble, Siemens, Walmart and Zalando. Headquartered in Switzerland, Interroll has a global network of 36 companies with sales of CHF 527.1 million and around 2,300 employees (2024).

interroll.com

Interroll reserves the right to modify the technical features of its products at any time. Technical information, volumes, data and features are only rough guidelines.

© Interroll 2026

